

MASTER COPY
DO NOT DESTROY

UNCLASSIFIED

TECHNICAL MANUAL

for

GENERAL PURPOSE TRANSMITTER

MODEL SBT-350 WAX1



THE TECHNICAL MATERIEL CORPORATION
MAMARONECK, N.Y. **OTTAWA, ONTARIO**



2
3
4
5
6
7
8
9
10

★
UNCLASSIFIED

TECHNICAL MANUAL

for

GENERAL PURPOSE TRANSMITTER

MODEL SBT-350 WAX 1



THE TECHNICAL MATERIEL CORPORATION
MAMARONECK, N.Y.

OTTAWA, ONTARIO

COPYRIGHT 1967
THE TECHNICAL MATERIEL CORPORATION

★
Issue Date: 10 April, 1967



THE TECHNICAL MATERIEL CORPORATION

C O M M U N I C A T I O N S E N G I N E E R S

700 FENIMORE ROAD

MAMARONECK, N. Y.

W a r r a n t y

The Technical Materiel Corporation, hereinafter referred to as TMC, warrants the equipment (except electron tubes,*fuses, lamps, batteries and articles made of glass or other fragile or other expendable materials) purchased hereunder to be free from defect in materials and workmanship under normal use and service, when used for the purposes for which the same is designed, for a period of one year from the date of delivery F.O.B. factory. TMC further warrants that the equipment will perform in a manner equal to or better than published technical specifications as amended by any additions or corrections thereto accompanying the formal equipment offer.

TMC will replace or repair any such defective items, F.O.B. factory, which may fail within the stated warranty period, PROVIDED:

1. That any claim of defect under this warranty is made within sixty (60) days after discovery thereof and that inspection by TMC, if required, indicates the validity of such claim to TMC's satisfaction.
2. That the defect is not the result of damage incurred in shipment from or to the factory.
3. That the equipment has not been altered in any way either as to design or use whether by replacement parts not supplied or approved by TMC, or otherwise.
4. That any equipment or accessories furnished but not manufactured by TMC, or not of TMC design shall be subject only to such adjustments as TMC may obtain from the supplier thereof.

Electron tubes*furnished by TMC, but manufactured by others, bear only the warranty given by such other manufacturers. Electron tube warranty claims should be made directly to the manufacturer of such tubes.

TMC's obligation under this warranty is limited to the repair or replacement of defective parts with the exceptions noted above.

At TMC's option any defective part or equipment which fails within the warranty period shall be returned to TMC's factory for inspection, properly packed with shipping charges prepaid. No parts or equipment shall be returned to TMC, unless a return authorization is issued by TMC.

No warranties, express or implied, other than those specifically set forth herein shall be applicable to any equipment manufactured or furnished by TMC and the foregoing warranty shall constitute the Buyers sole right and remedy. In no event does TMC assume any liability for consequential damages, or for loss, damage or expense directly or indirectly arising from the use of TMC Products, or any inability to use them either separately or in combination with other equipment or materials or from any other cause.

*Electron tubes also include semi-conductor devices.

TABLE OF CONTENTS

| <u>Paragraph</u> | | <u>Page</u> |
|--|--|-------------|
| <u>SECTION 1 - GENERAL INFORMATION</u> | | |
| 1-1 | Purpose of Equipment | 1-1 |
| 1-2 | Physical Description. | 1-1 |
| 1-3 | Equipment Make-up | 1-1 |
| 1-4 | Description of Equipment | 1-1 |
| 1-5 | Electrical Characteristics | 1-3 |
| <u>SECTION 2 - INSTALLATION</u> | | |
| 2-1 | Unpacking and Handling | 2-1 |
| 2-2 | Installation | 2-1 |
| 2-3 | Connection of External Equipment | 2-4 |
| <u>SECTION 3 - OPERATOR'S SECTION</u> | | |
| 3-1 | General | 3-1 |
| 3-2 | Functions of Major Components. | 3-1 |
| 3-3 | Tuning VOX-5 | 3-2 |
| 3-4 | Tune-up of Carrier | 3-2 |
| 3-5 | CW Operation | 3-6 |
| 3-6 | SSB Operation. | 3-6 |
| 3-7 | ISB Operation. | 3-6 |
| 3-8 | AM Operation | 3-6 |

TABLE OF CONTENTS (CONT)

| <u>Paragraph</u> | | <u>Page</u> |
|--|---------------------------------------|-------------|
| <u>SECTION 4 - PRINCIPLES OF OPERATION</u> | | |
| 4-1 | General | 4-1 |
| 4-2 | Overall Functional Analysis | 4-1 |
| <u>SECTION 5 - MAINTENANCE</u> | | |
| 5-1 | Preventive Maintenance. | 5-1 |
| 5-2 | Troubleshooting. | 5-2 |
| 5-3 | Repair and Replacement. | 5-2 |
| 5-4 | Operational Checks. | 5-3 |
| <u>SECTION 6 - PARTS LIST</u> | | |
| 6-1 | Introduction. | 6-1 |

LIST OF ILLUSTRATIONS

| <u>Figure</u> | | <u>Page</u> |
|--|---|-------------|
| <u>SECTION 1 - GENERAL INFORMATION</u> | | |
| 1-1 | General Purpose Transmitter, Model SBT-350 WAX1 | 1-0 |
| <u>SECTION 2 - INSTALLATION</u> | | |
| 2-1 | Slide Mounting Details. | 2-2 |
| 2-2 | Line Voltage Modification, APP-5 | 2-3 |
| 2-3 | Connection Diagram, External Equipment | 2-6 |
| 2-4 | Antenna Connection Diagram. | 2-7 |
| 2-5 | System Cabling Diagram. | 2-8/2-9 |
| <u>SECTION 4 - PRINCIPLES OF OPERATION</u> | | |
| 4-1 | Simplified Block Diagram. | 4-3 |

LIST OF TABLES

| <u>Table</u> | | <u>Page</u> |
|--|-----------------------------------|-------------|
| <u>SECTION 1 - GENERAL INFORMATION</u> | | |
| 1-1 | Major Components. | 1-4 |
| <u>SECTION 5 - MAINTENANCE</u> | | |
| 5-1 | Test Equipment Required | 5-3 |

674.3-7

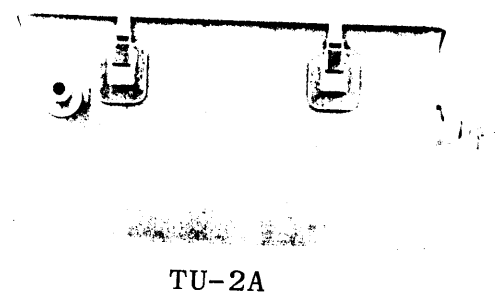
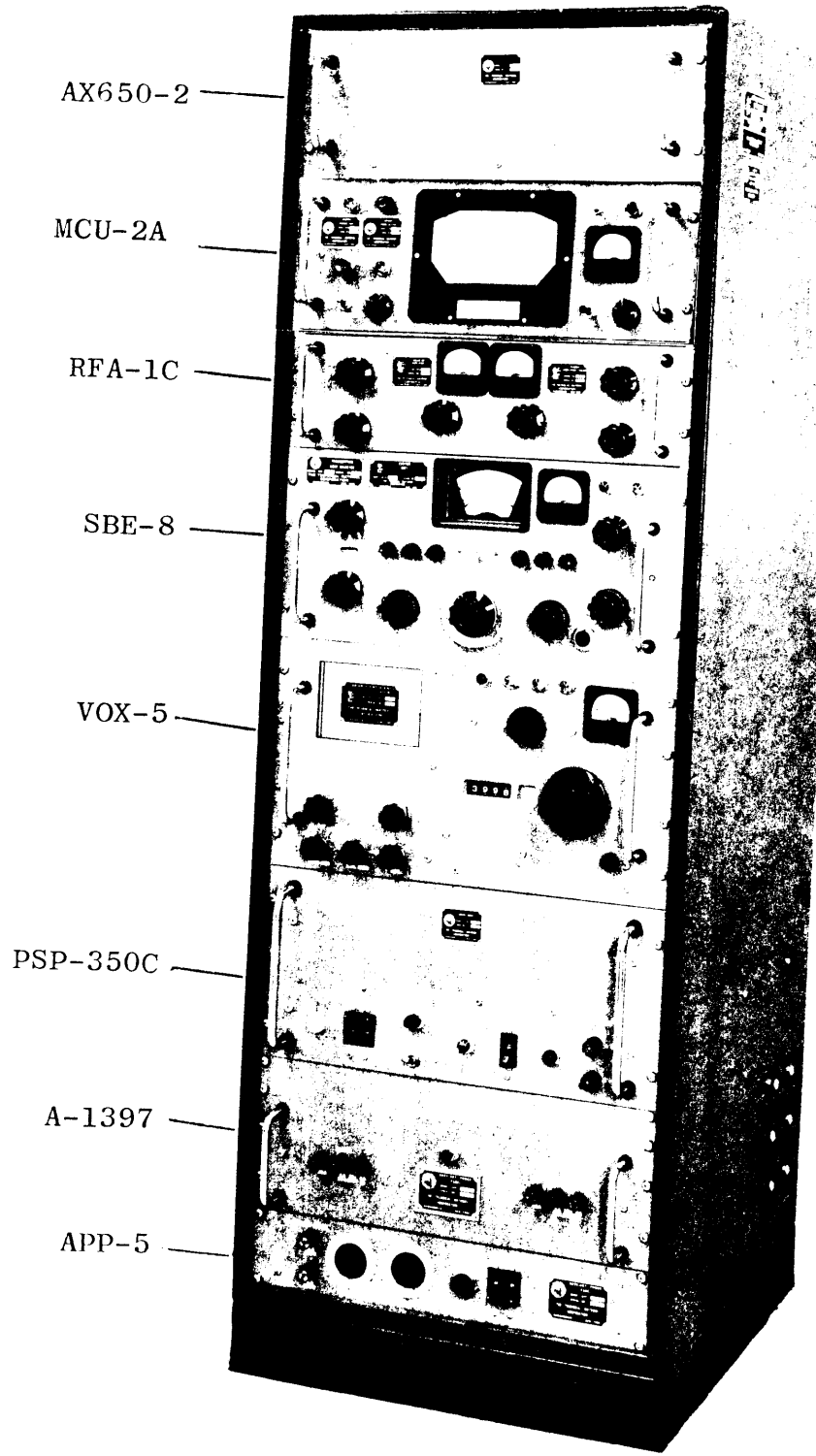

Figure 1-1. General Purpose Transmitter, Model SBT-350WAX1

SECTION 1

GENERAL INFORMATION

1-1. PURPOSE OF EQUIPMENT

General Purpose Transmitter, Model SBT-350 WAX1 (figure 1-1) is a general purpose transmitter system, operating in the frequency range of 2.0 to 32 megacycle (MHz).

The SBT is designed for use as a high-speed simplex transmit/receive sideband system for voice, CW, FSK and FAX operation. The rated output of the SBT is 350 watts PEP (200 watts for CW). An electronic TR switch in the AX650-2 modular unit is rated above the power ratings of the radio frequency output and produce a negative voltage, used for squelching a receiver during the transmit mode of operation.

1-2. PHYSICAL DESCRIPTION

The SBT-350 is contained in a single rack. All components are removable, the major one mounted on drawer slides. The unit contains its own forced-air cooling system, consisting of two exhaust blowers and air filter on the rear rack door, a blower for the power amplifier tubes in the PAL-350C sub-system and a filtered air intake at the top of the rack.

1-3. EQUIPMENT MAKE -UP

The major components comprising the SBT are listed in table 1-1. See figure 1-1 for physical equipment mounting locations and paragraph 1-4 for component descriptions.

1-4. DESCRIPTION OF EQUIPMENT

The following components comprise the exciter section.

(1) Antenna Tuning System, ATS-2A sub-system provides accurate indication of voltage standing wave ratio in the antenna and simultaneously provides indications of forward and reflected power with the addition of controls to provide a high degree of match between the transmitter and a large range of antenna loads. The ATS-2A sub-system comprises the Monitor Control MCU-2A, Directional Coupler CU-2A and Antenna Tuner TU-2A.

(2) Model PAL-350C Linear Power Amplifier sub-system amplifies the output of the SBE exciter up to 350 watts. The PAL-350C sub-system comprises the Power Supply PSP-350C, Linear Amplifier RFA-1C.

(3) Transmitting Mode Selector Model SBE-8 is the exciter unit in the transmitter. From two audio input channels or mike input, it translates intelligence into single or independent sidebands with suppressed carrier or any degree of carrier in the 1.75 to 32 megacycle range. It also generates conventional AM signal and may be operated with a hand keyer for CW transmission.

(4) Variable Frequency Oscillator Model VOX-5 is a precise, direct reading, variable frequency oscillator with high stability. It supplies a continuously adjustable 2-4 mc injection frequency to the SBE exciter, thus providing a multitude of carrier frequencies through the 2 to 32 megacycle range.

(5) Auxiliary Power Panel Model APP-5 distributes line voltage to the individual components and rack blowers. In addition, it contains terminal blocks on the rear of the unit for connection of equipment external to the SBT-350.

(6) RF Coupling Unit, AX650-2 comprises a directional coupler CU-2 and a T/R switching network. The AX650-2 provides a means of operating a transmitter and an associated receiver with one common antenna.

1-5 ELECTRICAL CHARACTERISTICS

| | |
|------------------------------|--|
| Output Power: | 350 watts PEP for SSB, ISB and AM. 200 watts average for CW. |
| Frequency Range: | 2.0 to 32 mc. continuously adjustable |
| Modes Of Operation | CW, SSB, ISB and AM (sideband modes with suppressed carrier or any degree of carrier) |
| Output Imedance: | Will match any unbalanced load from 70- to 150-ohms at +20 degrees in the range of 2 to 4 mc and any unbalanced load from 50 - to 600-ohms +45 degrees in the range of 4 to 32 megacycles. |
| Frequency Stability: | Maximum error, 100 cps at 32 mc for any fixed temperature within 0 to 50°C in a 24 hour period. |
| Signal/distortion Ratio: | Distortion at least 40 db below either tone of a standard two-tone test. |
| Unwanted sideband Rejection: | 500 cps single tone, 60 db down from PEP output. |
| Carrier Insertion: | 55 db down from PEP output to 0 db, continuously adjustable. |
| Spurious Signals: | 50 db down from PEP output. |
| Harmonic Suppression: | Second - at least 45 db below PEP output. Third - at least 55 db below PEP output. |
| Audio Input: | 1) Two 600-ohm channels, balanced or unbalanced, -20 dbm to +20 dbm. 2) One 500,000-ohm input for crystal or dynamic mike, -50 dbm for full PEP output. |
| Audio Response: | Flat within 3 db for 350- to 3300-cps range. |

1-5 ELECTRICAL CHARACTERISTICS (Cont)

| | |
|----------------------|--|
| VOX Operation: | Voice control with anti-trip features (adjustable gain and squelch) |
| Frequency Control: | VOX-5: continuously variable, direct reading variable oscillator. |
| Noise Level: | 60 db down from PEP output. |
| Safety features: | <ol style="list-style-type: none"> 1) ALDC (automatic load and drive control) 2) Full interlock system 3) Full overload and fuse protection |
| Primary power Input: | 115/230 VAC, 50/60 cps single phase |
| Power consumption: | 1,050 watts average |
| Heat dissipation: | 700 watts average |
| Cooling system: | Filtered forced-air blower system |
| Environmental: | Designed to operate in any ambient temperature between 0 and 50°C and for any value of humidity up to 90%. |

TABLE 1-1. MAJOR COMPONENTS

| TMC DESIGNATION | |
|--|------------------------------------|
| Transmitting Mode Selector, Model SBE-8 | |
| Power Supply, A-1397 | |
| Variable Frequency Oscillator, Model VOX-5 | |
| Monitor Control Unit, Model MCU-2A | PART OF ATS-2A SUB-SYSTEM |
| Antenna Tuner, Model TU-2A | |
| Power Supply, Model PSP-350C | PART OF PAL-350 C SUB-SYSTEM |
| Linear RF Amplifier, Model RFA-1C | |
| Auxiliary Power Panel, Model APP-5 | |
| RF Coupling Unit, AX650-2 | |

SECTION 2

INSTALLATION

2-1. UNPACKING AND HANDLING

Each modular unit comprising the SBT system has been thoroughly inspected and tested at the factory before shipment. Upon arrival of the equipment, inspect each packing case and its contents immediately for possible damage. Unpack the equipment carefully. Inspect all packing material for parts which may have been shipped as loose items.

With respect to damage to the equipment for which the carrier is liable, The Technical Materiel Corporation will assist in describing methods of repair and the furnishing of replacement parts.

2-2. INSTALLATION

All of the units used in the SBT system are equipped with standard width 19-inch front panels. These units are to be mounted in the equipment rack as shown in figure 1-1. Figure 2-5 illustrates electrical interconnections of the SBT modular units. Refer to the individual technical and sub-system manuals for detailed connection and installation procedures.

a. INSTALLATION OF MODULAR UNITS. - Refer to figure 1-1 for modular unit mounting locations. Some modular units are slide-mounted on pull-out, or tilt-lock drawer slides. To install any slide-mounted unit in its compartment, see figure 2-1 and proceed as follows:

1. Untape or unstrap cable assemblies and all other components fastened to the rack frame for shipment.

CAUTION

Start by installing bottom units first in order to avoid rack tripping over from extended center of gravity.

2. Pull center section of associated compartment track out until it locks in an extended position.
3. Position slide mechanisms of modular unit in tracks and ease modular unit forward into rack until release buttons engage holes in track.
4. Make necessary cable and electrical connections as shown in figure 2-5. To prevent cables from snagging, utilize the cable retractors, located at the inside-rear of the rack.
5. Depress release buttons and slide modular unit completely into compartment.
6. Secure front panel of modular unit to rack with screws and washers.

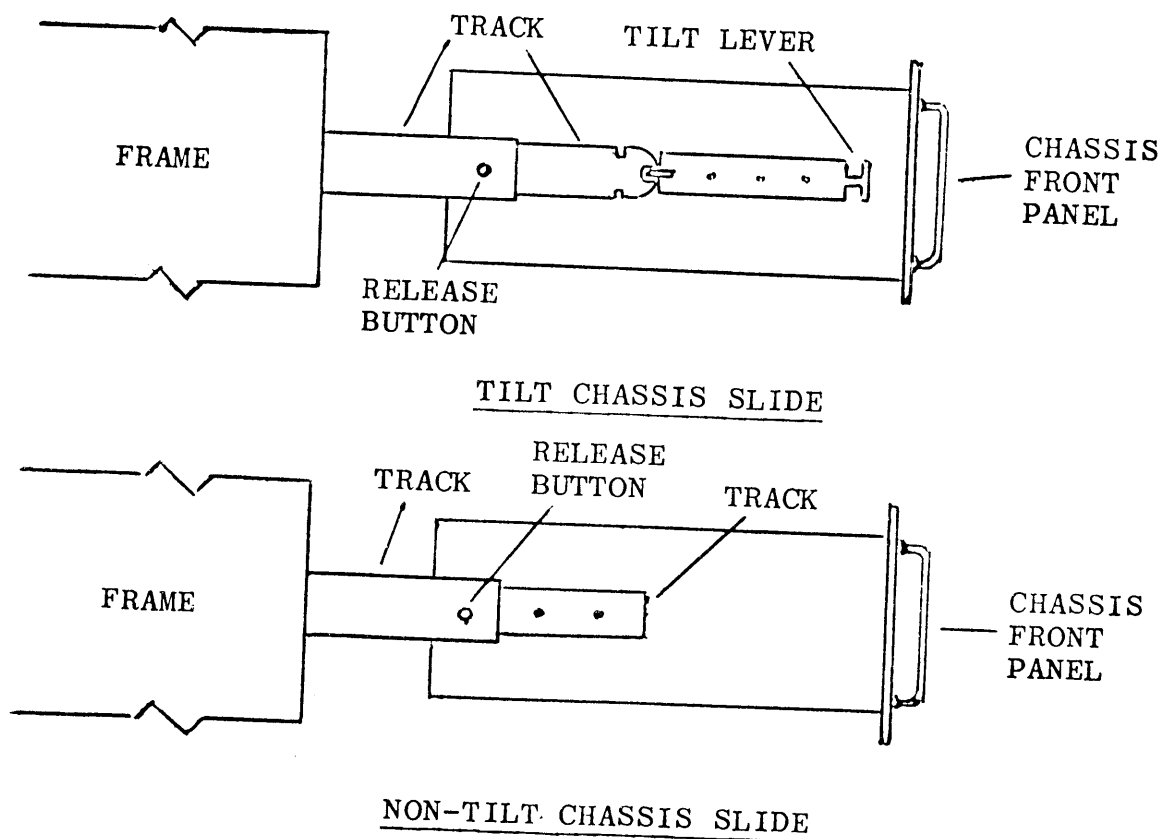
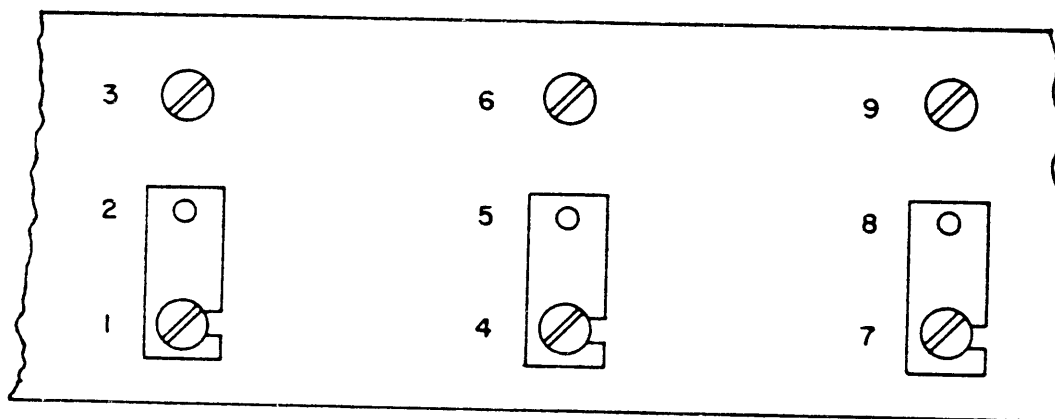

Figure 2-1. Slide Mounting Details

b. PRIMARY POWER INPUT CONNECTIONS - The SBT is factory wired to operate from a line voltage source of 115 volts a-c, 50/60 cps, single phase power. The line voltage cable (customer supplied) is to be connected to the SBT via connector J701, located at the bottom rear of the rack. To convert the SBT for operation from a 230 volts a-c power source, make the necessary strap-changeover connections shown in figure 2-2. Refer to the individual modular unit technical manuals for modular unit power input changeover connections.

A utility a-c power source may be connected to the SBT via connector J702. See figure 2-5 for system interconnections.



APP-5 BUS STRAP ARRANGEMENT

NOTES:

1. For 115VAC operation, connect terminals 1 and 2, 4 and 5, 7 and 8.
2. For 230VAC operation, connect terminals 2 and 3, 5 and 6, 8 and 9.

Figure 2-2. Line Voltage Modification, APP-5

2-3. CONNECTION OF EXTERNAL EQUIPMENT

a. Introduction - Except for the antenna and mike connections, all external connections are made at two terminal blocks, E501 and E502, located at the rear of APP-5. Wires may be brought into the transmitter through one of the four holes (with cover plates) near the bottom of the rack. Figure 2-2 and the following paragraphs illustrate the possible external connections to the transmitter.

b. Remote Transmitter Plate Relay - Terminals 1 and 2 of E501 are provided for attachment to the coil of a relay supplying plate voltage to an additional stage of r-f amplification external to the SBT-350. Such a relay is sometimes employed in larger transmitter systems of which SBT-350 is a sub-assembly.

c. Regulated 115 VAC - Terminals 3 and 4 are available for an extension source of the regulated 115 VAC used in the PAL-350 power supply sequential relay system. This 115 VAC becomes available after the sequential relays have acted to turn the transmitter on. It may be used to energize an antenna relay in cases where a common antenna is used for both transmitter and receiver.

d. External Interlocks - Terminals 5, 6, 7, and 8 are provided for connection of additional safety interlock/s external to the SBT-350. Such additional interlock/s will be in series with the SBT-350 interlock and form another link in the interlock circuit. When these terminals are not used in this way, the jumpers remain in place.

e. Push-to-talk System - Terminals 9 and 10 are provided for a push-to-talk button attachment.

f. Receiver Squelch - Terminals 11 and 12 are provided for attachment to receiver audio output, if receiver "squelch" is desired when using VOX (voice-operated) feature in the SBE unit. Receiver squelch is used in order to prevent sound from a nearby receiver from automatically actuating the VOX circuit.

g. Audio Input - Channels 1 and 2 - Terminals 13 through 20 are provided for the attachment of two separate sources (or channels) of intelligence in the form of 600-ohm audio. Figure 2-2 illustrates connections for either balanced or unbalanced inputs.

h. Key Line - Terminals 21 and 22 are provided for the attachment of a hand-keying device for CW transmission (interrupted carrier). Pushing down on key grounds the cathode circuit of V118, 1st r-f amplifier, in the SBE unit, enabling it to operate. Leave jumper wire in when keyer is not installed.

j. Antenna Connection - Refer to figure 2-3 for interconnecting cable installation between the ATS-2 Antenna Tuning System components and the antenna.

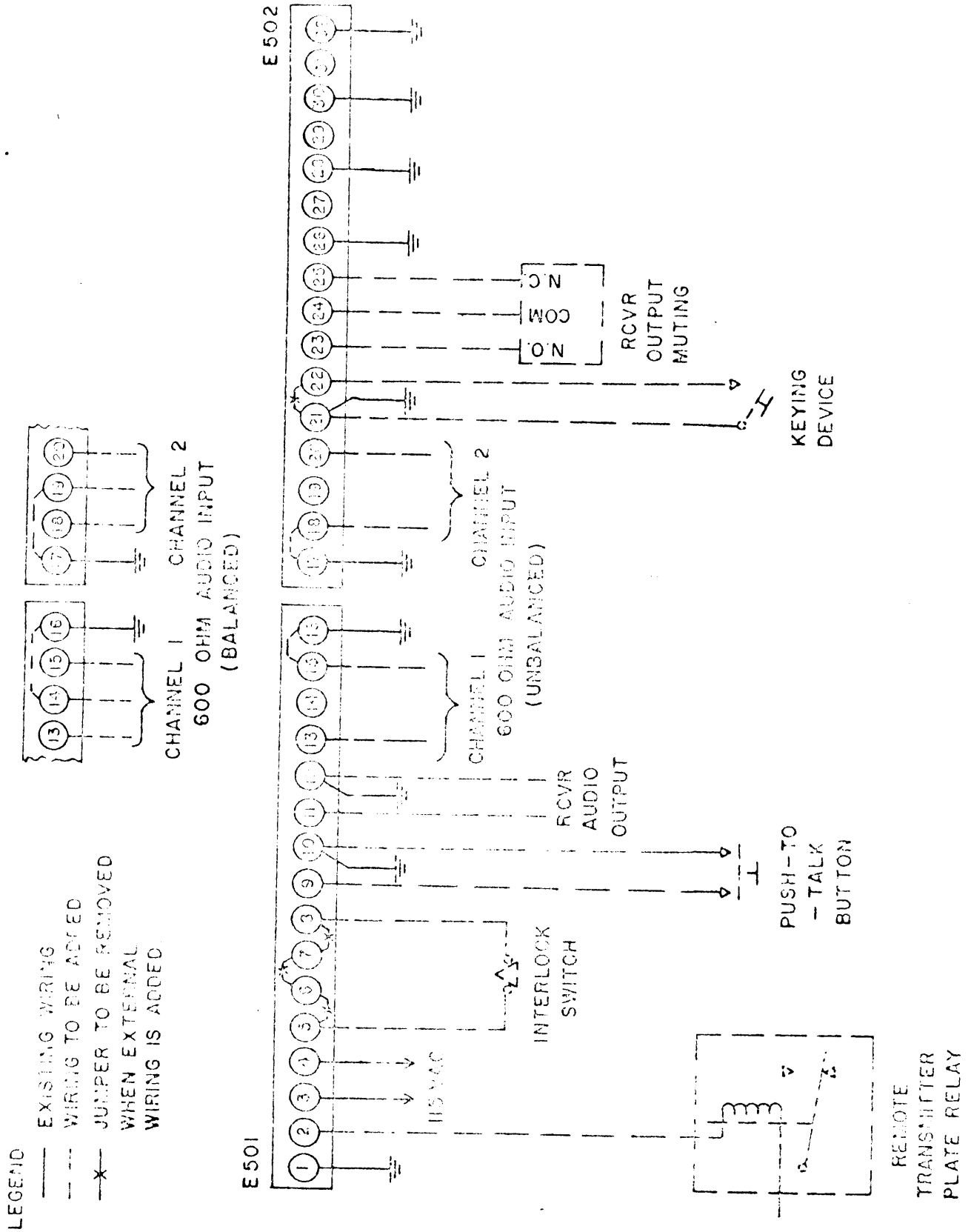

Figure 2-3. Connection Diagram, External Equipment

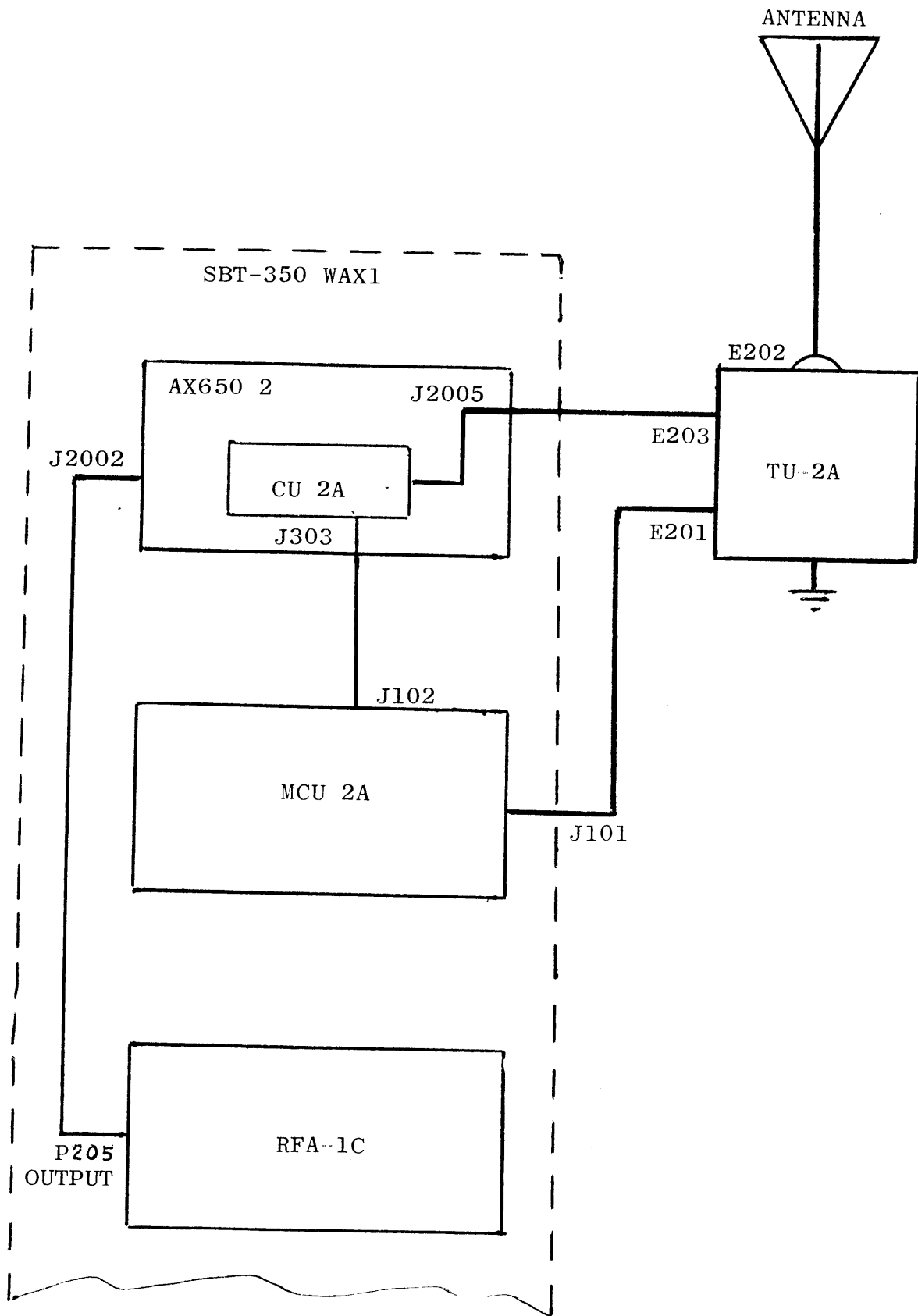

Figure 2-4. Antenna Connection Diagram

REDUCE TO 13 1/8

THE TECHNICAL MATERIEL CORP.

MAMARONECK, NEW YORK

MODEL SBT-350WAXI

CK1336-A

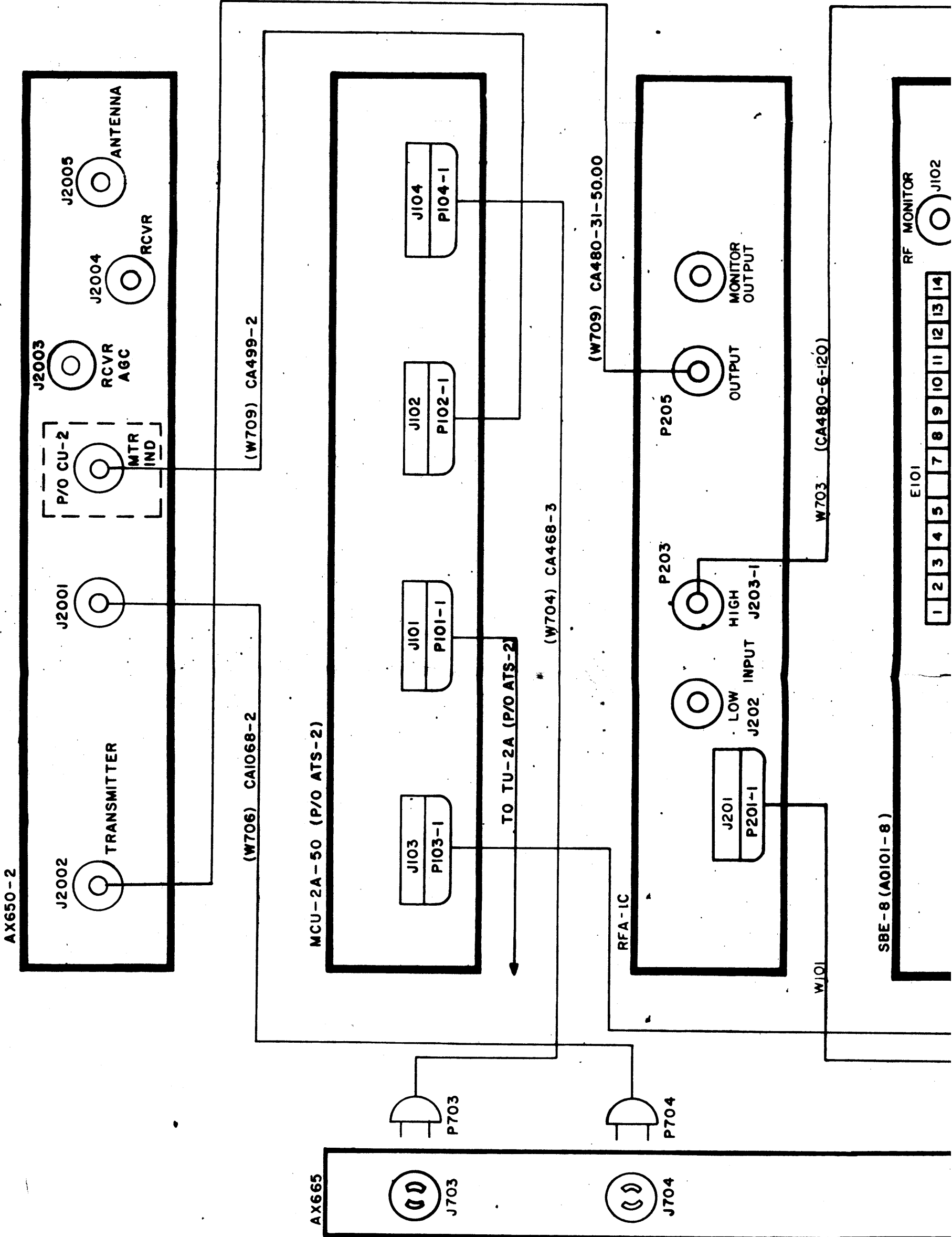

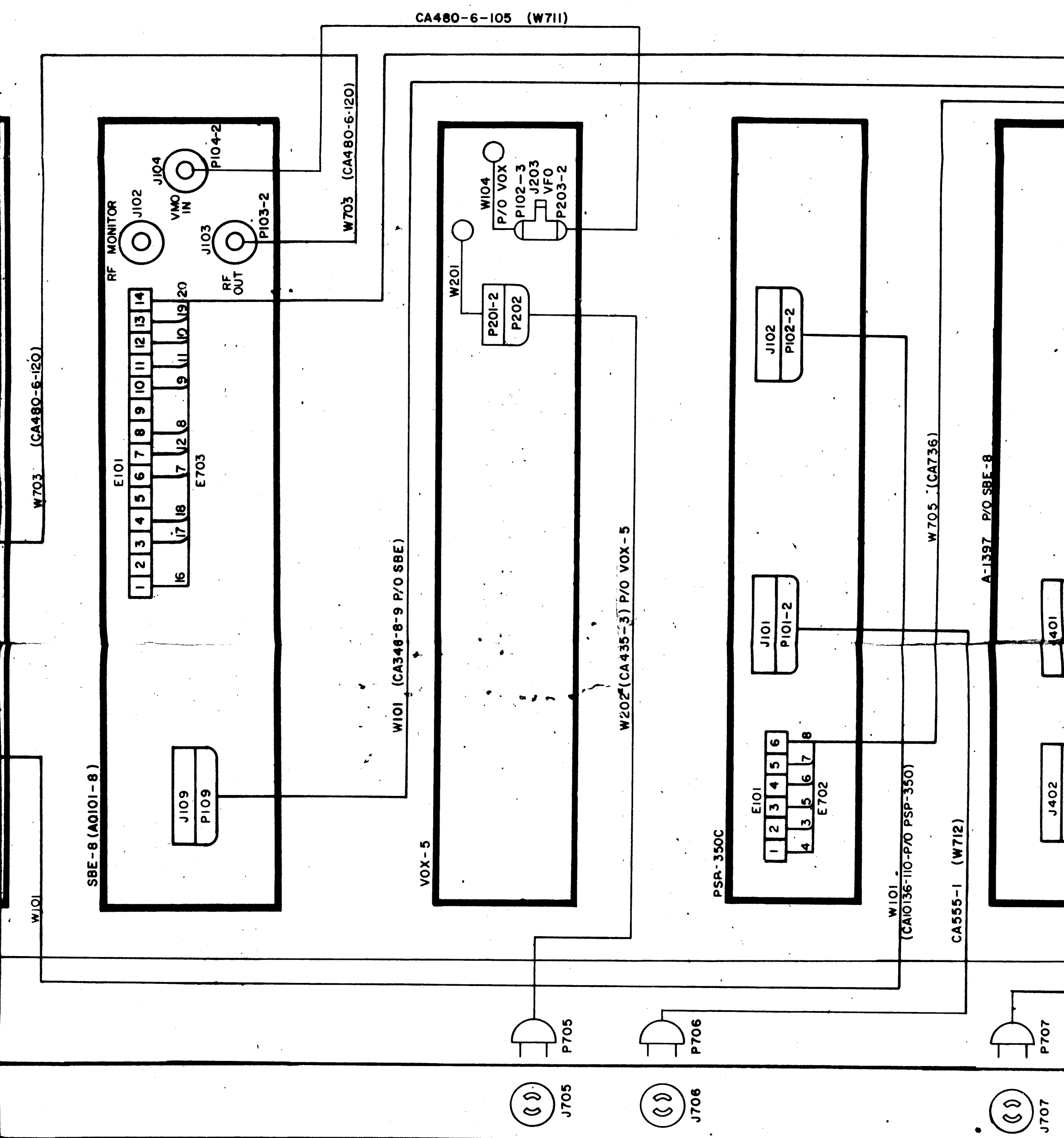

| REVISIONS | | | | | |
|-----------|-----|------------------------------|---------|----------|-------|
| ZONE | LTR | DESCRIPTION | DATE | E.M.N.NO | DRAW |
| | X | EXPERIMENTAL RELEASE | 3.31.67 | 4 | W.H.V |
| | Ø | FINAL RELEASE FOR PRODUCTION | 4-6-67 | Ø | C.V |
| | Δ | DRAWING REVISED & UPDATED | 1.2.67 | 18107 | W.H.V |

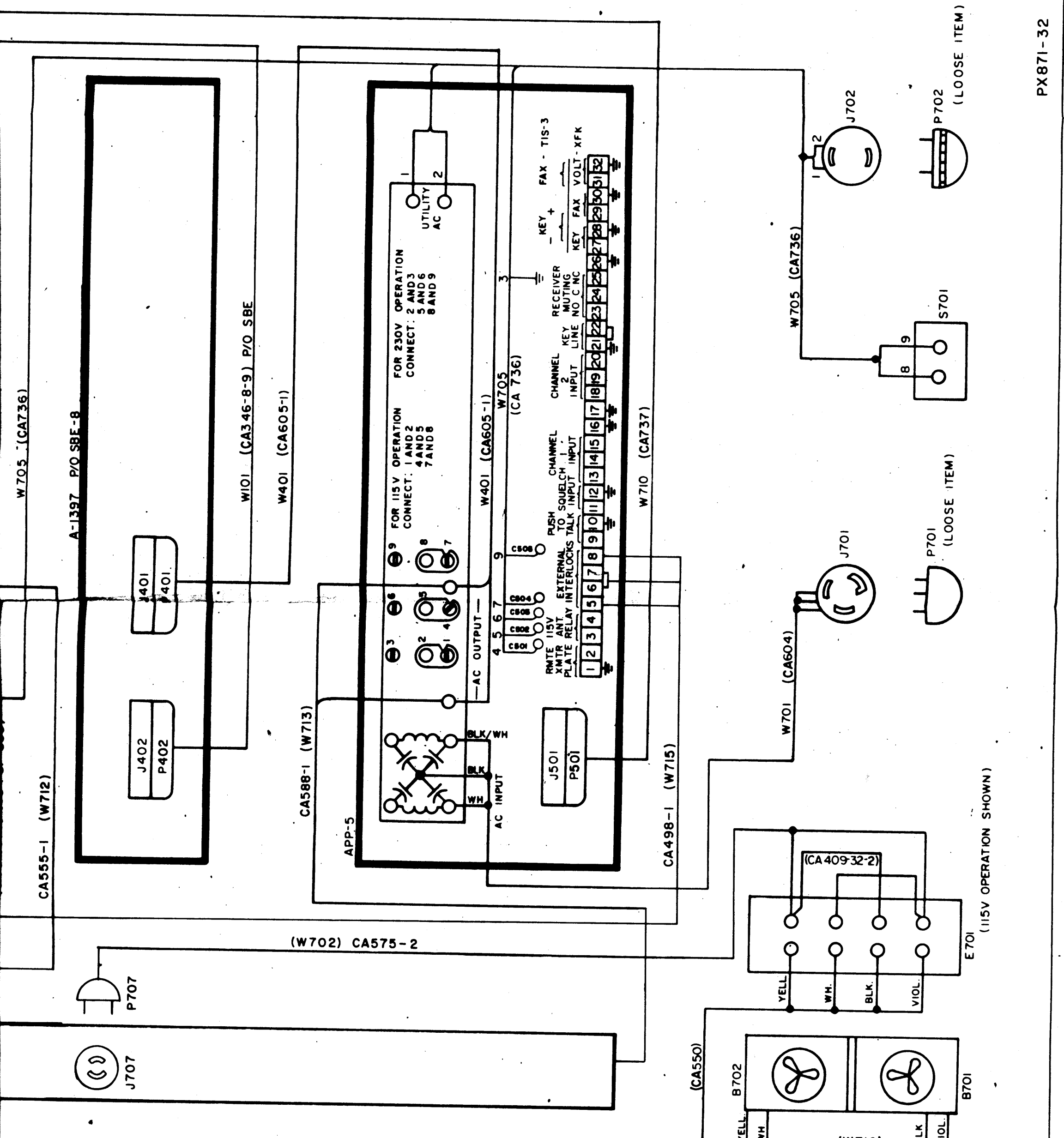

| REVISIONS | | | | | | |
|-----------|-----|-------------------------------------|---------|----------|--------|-----------|
| ZONE | LTR | DESCRIPTION | DATE | E.M.N.NO | DRAFT | CHKD APPD |
| | X | EXPERIMENTAL RELEASE | 3.31.67 | ← | W.H.W. | |
| | Ø | EXPERIMENTAL RELEASE FOR PRODUCTION | 4-6-67 | Ø | C.V. | |
| | Δ | DRAWING REVISED & UPDATED | 1.2.67 | 18107 | W.H.W. | F.O. Z.B. |

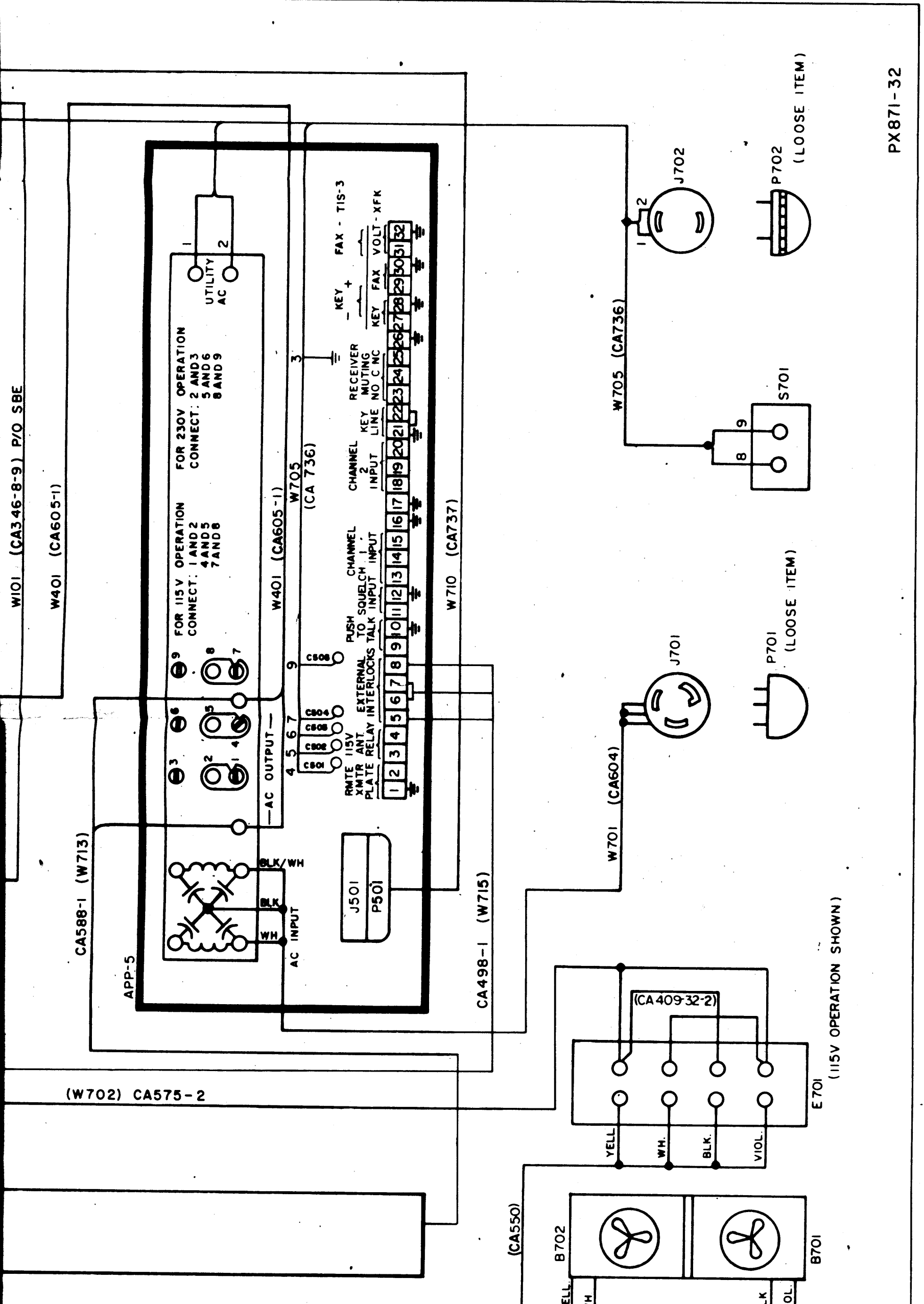

D

C

B

CK1336

THE
MODEL SB

AX650-2

J2002

TRANSMITTER

(W706) CA1068-2

MCU-2A-50 (P/O ATS-2)

J103
P103-1

TO TU-2A (P/OA)

RFA-1C

J201
P201-1

J202
LOW

W101

SBE-8 (AQ101-8)

AX665

J703

P703

J704

P704

PICTORIAL

13 1/8

13 5/8

LAMIN
FOR

8

7

6

A

R

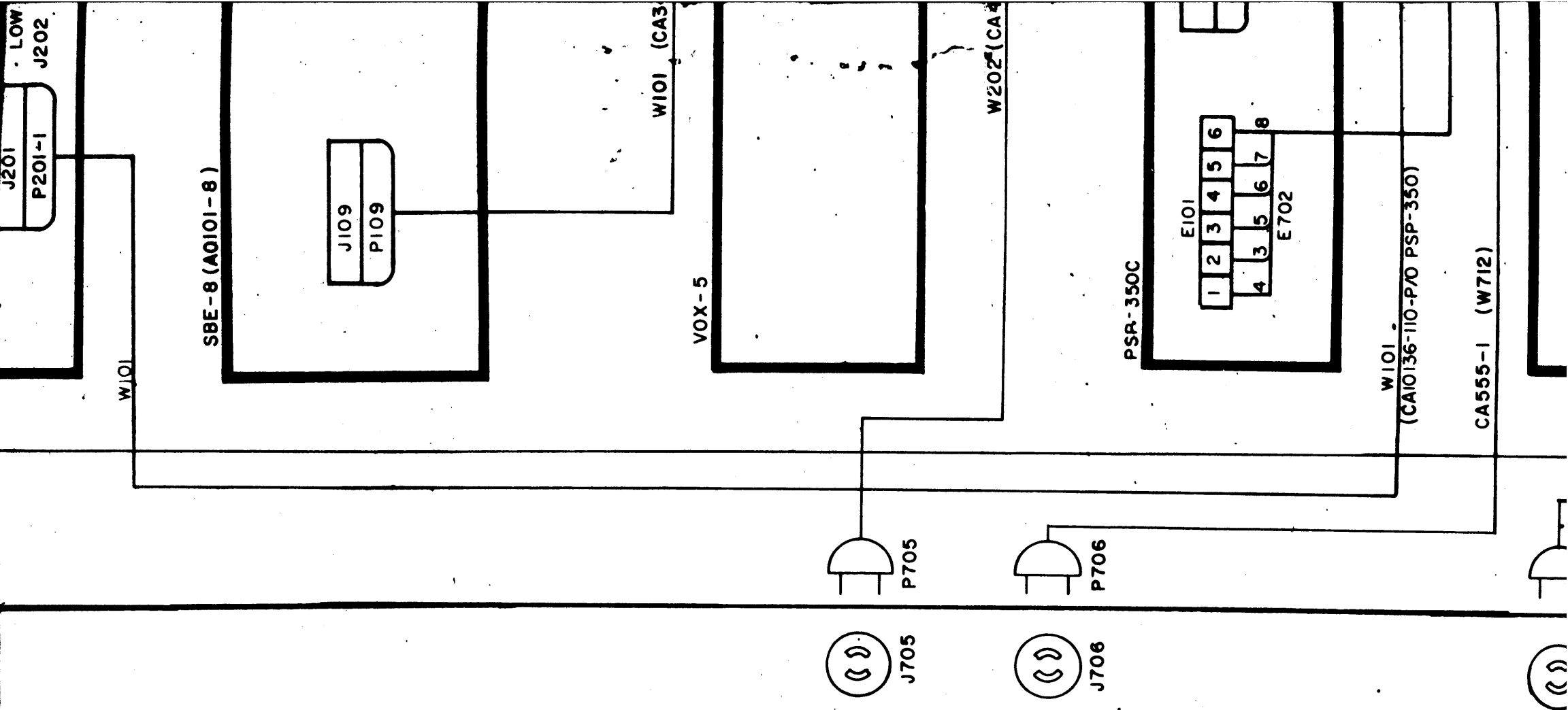

LAMINATING DETAIL:
FOR REFERENCE ONLY

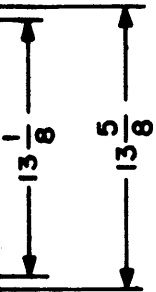

| | | |
|-------------|---------------|---|
| 1 | SBT-350WAXI | |
| QTY / UNIT | MODEL USED ON | A |
| APPLICATION | | |
| | CODE | |

NOTICE TO PERSONS RECEIVING THIS DRAWING
 THE TECHNICAL MATERIEL CORPORATION claims proprietary right in the material contained herein. This drawing is issued in confidence for engineering information only and may not be reproduced or to manufacture anything shown hereon without permission from THE TECHNICAL MATERIEL CORPORATION. This drawing is loaned for mutual assistance and is subject to recall at any time.

6

5



4

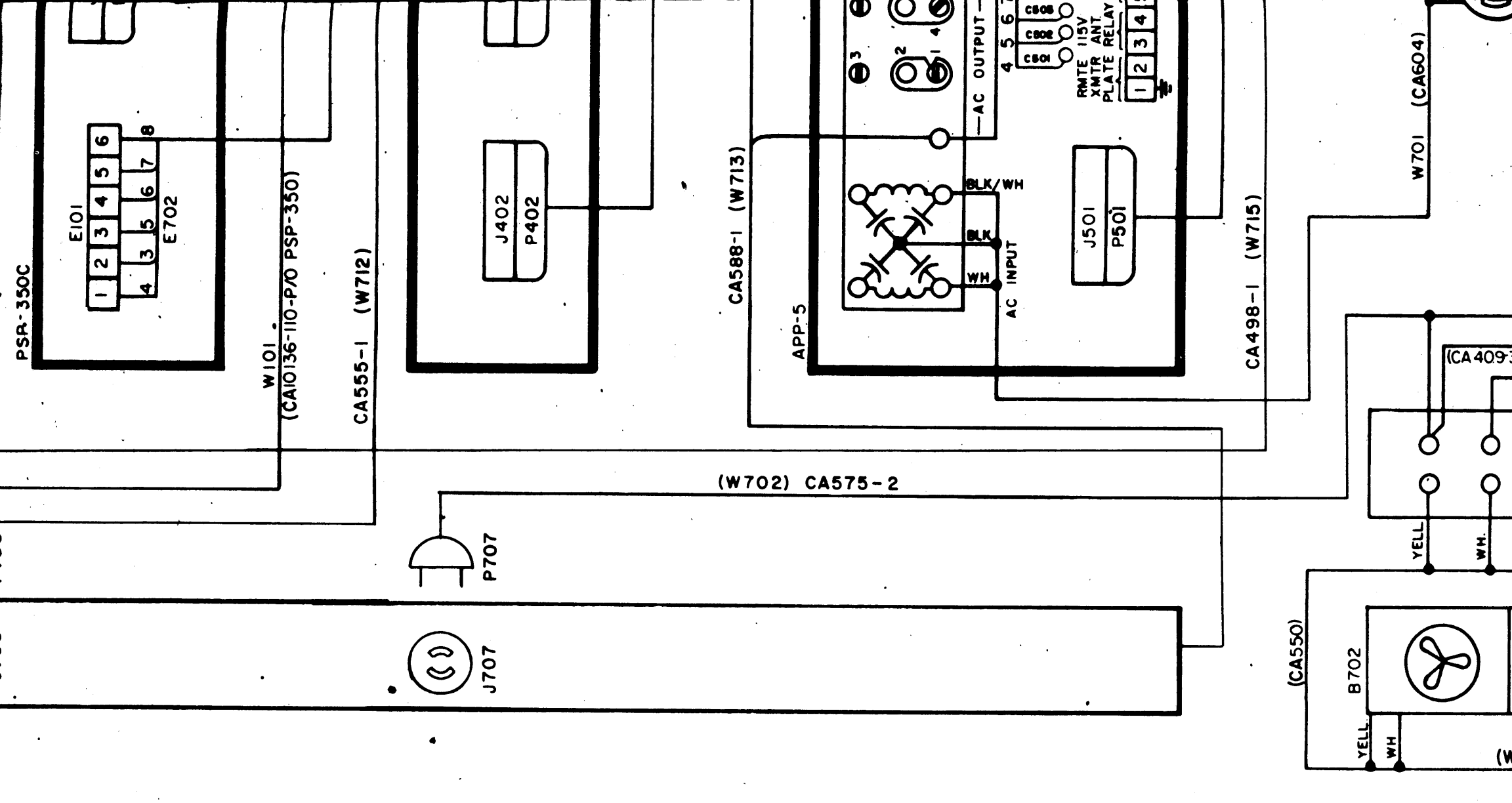

REF: 871-32

| SBT-350WAXI | | | LIST OF MATERIALS | |
|---|------|----------|------------------------------------|--|
| QTY. REQ. | ITEM | PART NO. | THE TECHNICAL MATERIEL CORPORATION | |
| UNLESS OTHERWISE SPECIFIED DIMENSIONS ARE IN INCHES AND INCLUDE CHEMICALLY APPLIED OR PLATED FINISHES | | | MATERIAL | |
| TOLERANCES ON | | | FINISH | |
| DECIMALS .X ± .05 .XX ± .01 .XXX ± .005 | | | MIL CR | |
| FRACTIONS ± 1/64 ANGLES ± 0°-30' | | | SIZE CODE IDENT. NO. D 82679 | |
| MATERIAL | | | SCALE Figure | |
| FINISH | | | 4 3 2 | |
| NOTICE TO PERSONS RECEIVING THIS DRAWING | | | MIL CR 2 | |
| THE TECHNICAL MATERIEL CORPORATION claims proprietary right in the material disclosed hereon. This drawing is issued in confidence for engineering information only and may not be reproduced or used for the manufacture of any part or assembly shown hereon without permission from THE TECHNICAL MATERIEL CORPORATION. This drawing is loaned for mutual assistance and is subject to recall at any time. | | | | |

| L. BUTLER | | DATE | |
|----------------|--------------------|--------|---------|
| FINAL APPROVAL | <i>[Signature]</i> | 4/6/67 | |
| MECH. DES. | <i>[Signature]</i> | 4/5/67 | |
| ELECT. DES. | <i>[Signature]</i> | 4/1/67 | |
| CHECKED | <i>[Signature]</i> | | |
| DRAWN | W. WILLIAMS | DATE | 3.30.67 |

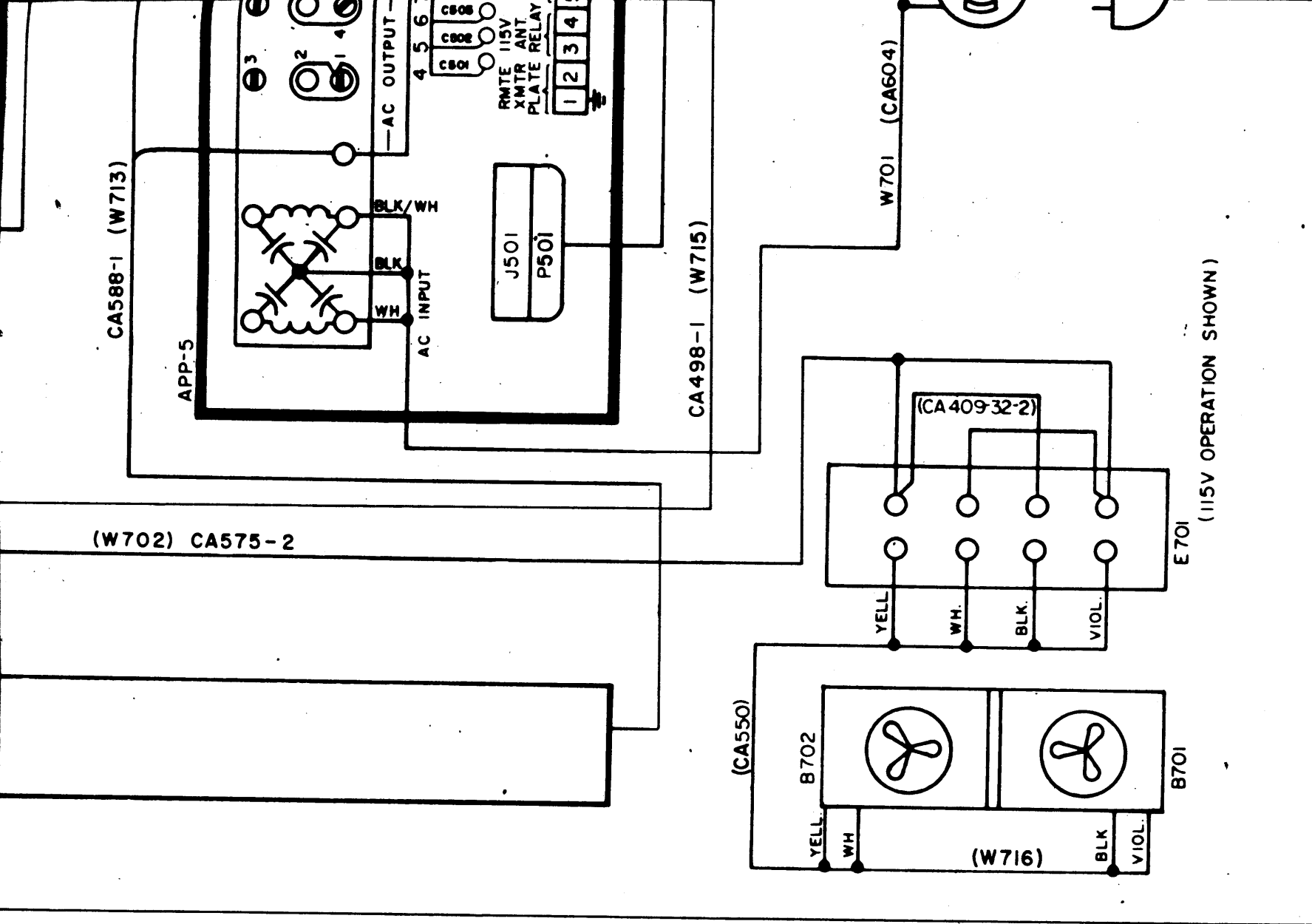

B
CK1336

REF: 871-32

| QTY. REQ. | ITEM | PART NO. | DESCRIPTION | SYMBOL |
|--|------|----------|---|--------|
| L. BUTLER LIST OF MATERIAL | | | | |
| UNLESS OTHERWISE SPECIFIED DIMENSIONS ARE IN INCHES AND INCLUDE CHEMICALLY APPLIED OR PLATED FINISHES TOLERANCES ON DECIMALS: .X ± .05, .XX ± .01, .XXX ± .005 FRACTIONS: ± 1/64, ANGLES: ± 0° 30' | | | THE TECHNICAL MATERIEL CORP. MAMARONECK, NEW YORK WIRING, DIAGRAM SBT-350WAXI | |
| FINAL APPROVAL: <i>[Signature]</i> DATE: 4/6/67 MECH. DES: <i>[Signature]</i> DATE: 4/5/67 ELECT. DES: <i>[Signature]</i> DATE: 4/1/67 CHECKED: <i>[Signature]</i> DATE: 4/1/67 DRAWN: W. WILLIAMS DATE: 3.30.67 | | | SIZE: D CODE IDENT. NO.: 82679 DWG NO.: CK1336 ISSUE: A | |
| SERIAL: <i>[Symbol]</i> SH: <i>[Symbol]</i> | | | SCALE: Figure 2-5. System Cabling Diagram DF | |

A

3 M/L CR 2 1

SECTION 3

OPERATOR'S SECTION

3-1. GENERAL

a. Tuning Procedures - This section provides a general outline for tuning up the SBT-350. Detailed tuning steps for the individual components are contained in the associated modular unit and sub-system technical manuals.

b. Modes of Transmission - There are four general modes of transmission available. These are:

- (1) CW telegraphy (keyed carrier with hand keying)
- (2) SSB (single sideband with voice or audio signal input and suppressed or partial carrier)
- (3) ISB (isolated sidebands with voice and/or audio signal inputs and suppressed or partial carrier)
- (4) AM (both sidebands and full carrier with voice or audio signal input)

3-2. FUNCTIONS OF MAJOR COMPONENTS

a. All Modes - In all modes of transmission, the carrier is tuned up first, even though it may be suppressed in transmission, as in some sideband modes. The carrier is generated by the SBE and VOX and amplified by PAL-350. The ATS-2A sub-system provides an indication of VSWR in final tuning and loading adjustments also containing additional tuning adjustments for a wide range of loading conditions.

b. CW Mode - A hand keyer enables and disables the SBE.

c. SSB Mode - An audio signal from channel 1, channel 2, or mike input is injected into either the upper or lower sideband at SBE. The carrier

is either suppressed or adjusted to some percentage and the signal is stepped up into the 2 to 32 megacycle range and amplified by PAL-350.

d. ISB Mode - Two separate audio intelligence sources from channels 1, 2, or mike input at SBE are injected into upper and lower sidebands. The carrier is either suppressed or adjusted to some percentage and the signal takes the same course as in SSB.

e. AM Mode - An audio signal from channel 1, channel 2 or mike input at SBE modulates the carrier. The signal is stepped up into the 2 to 32 megacycle range and amplified by PAL-350.

3-3. TUNING VOX-5

Only the master oscillator (2- 4 mc) section of VOX is utilized in the SBT-350 transmitter. All HFO controls are ineffective. When the carrier frequency has been determined, the following method is used to calculate the VOX 2- 4 mc output frequency:

Where f_o = carrier frequency (in mc)

Where N = SBE BAND MCS dial setting (bottom figure under range in which f_o falls)

Where f_{VOX} = VOX output frequency (setting as appears on MASTER OSCILLATOR FREQUENCY counters on VOX (in mc)

When f_o falls within 2 to 4.25 mc range:

$$f_{VOX} = f_o + 0.25$$

When f_o falls within 4.25 to 32.25 mc range:

$$f_{VOX} = 2N + 0.25 - f_o$$

3-4. TUNE-UP OF CARRIER

A preliminary 48-hour warm-up period for VOX and SBE ovens is required when tuning up SBT-350 for the first time. When transmitter is "off the air"

it may be left in its STANDBY condition in order to maintain oven temperatures.

Step 1 (Tuning VOX-5) - Determine carrier frequency (f_0) and, referring to paragraph 3-3 and VOX-5 manual, set and calibrate MASTER OSCILLATOR FREQUENCY (f_{VOX}) on VOX.

Step 2 (Tuning (SBE-8)) - On SBE, set LSB and USB switches to OFF and set LSB GAIN, USB GAIN, VOX GAIN and SQUELCH GAIN in their extreme CCW positions. Set EXCITER switch to ON; EXCITER lamp will light. Set BAND MCS knob to bring f_0 range reading on BAND MCS dial. Note bottom figure "N". It should be the same as that used in Step 1. Turn MR TUNING knob to bring f_{VOX} on lower movable dial on main tuning dial. Set OUTPUT TUNING center knob to appropriate range reading for f_0 . Set METER SW knob to MF. Adjust OUTPUT TUNING outer disc to bring a reading on the upper movable section of the main tuning dial which is slightly lower than f_0 . Then adjust MF TUNING knob to obtain a maximum reading on SBE output meter. If necessary, decrease the setting of CARRIER INSERT knob to avoid an off-scale meter reading.

NOTE

Reading on lower section of SBE main tuning dial should now correspond with reading on MASTER OSCILLATOR FREQUENCY counters on VOX.

Set METER SW knob to RF. With OUTPUT TUNING outer disc, increase the frequency reading on the upper movable section of the main tuning dial to the first peak reading on SBE output meter. Set OUTPUT knob to 0.

Step 3 (Tuning PAL-350 Driver) - On RFA-1, set DRIVER BAND and PA BAND knobs to appropriate ranges for f_0 . On PSP-350, set MAIN TUNING

knob to position indicated for f_o in table 3-3, "Driver Tuning Positions" in PAL-350 manual. Set MULTIMETER knob to RF DR 0-50V. In SBE, set OUTPUT knob to 1. On PSP-350, set TRANSMITTER PLATES switch to ON. After a 60-second interval, TRANSMITTER PLATES lamp will light. On RFA, readjust DRIVER TUNING knob to obtain a peak reading on MULTIMETER. Keep peak below 30v by operation of the SBE OUTPUT knob.

Step 4 (Tuning PAL-350 PA Stage) - On SBE, set OUTPUT knob to 0. On RFA, leave MULTIMETER switch set at RF DR 0-50V. On PSP-350, set HV LINE circuit breaker to ON. On SBE, slowly increase OUTPUT knob and observe RFA PA PLATE meter. Increase OUTPUT knob setting until PA PLATE meter indicates current of 200 ma. On RFA, adjust PA TUNING knob to obtain a dip on MULTIMETER. Then adjust PA LOADING knob to increase reading on MULTIMETER. Adjust SBE OUTPUT knob to obtain 30v on MULTIMETER. Readjust PA TUNING knob to obtain another dip and then readjust PA LOADING knob to obtain an increase. Readjust SBE OUTPUT knob to obtain a lower reading on MULTIMETER than that in the last OUTPUT knob adjustment. Repeat this loading procedure until approximately the values listed below are reached:

| <u>MULTIMETER switch position</u> | <u>MULTIMETER meter reading</u> |
|---------------------------------------|-------------------------------------|
| RF DR-0-50V - - - - - | 18v (max) |
| ISG -20, + 30 MA - - - - - | -5ma* |
| RF PL 0-2.5 KV - - - - - | 500v * |
| RF OUT 0-500V - - - - - | 70v |
| PA PLATE meter - - - - - | 270 ma* |

*During the entire loading procedure, use SBE OUTPUT knob to prevent the following readings from exceeding the following maximum values at any time:

MULTIMETER
switch position

MULTIMETER
Maximum reading

| | |
|---------------------------|-------------|
| ISG -20, +30 MA - - - - - | 15 ma |
| RF PL 0-2.5 KV - - - - - | 800v |
| PA PLATE meter - - - - - | 300 ma max. |

Step 5 (Final Tuning Adjustments) - On ATS-MCU-2, set TUNE/OPERATE switch to TUNE. Set POWER switch to X1. Observe power meter reading on FORWARD-WATTS scale. If necessary, back off SBE OUTPUT knob to bring reading to "10" (100 watts) or below. Set METER switch to HUM and observe reading on adjacent meter. Refer to "35 foot whip antenna measurement" table in ATS-2 manual. Set METER switch to RES and observe reading on meter. Depress RESISTANCE OPERATE button for 2 seconds, then read meter. Repeat until reading is obtained as indicated in above table appropriate for humidity reading and f_0 . Set METER switch to REACT. Operate REACTANCE switch towards INCR and DECR to minimize WATTS-REFLECTED and VSWR readings on power meter.

CAUTION

If f_0 is higher than 10 mc, make certain that REACTANCE scale readings do not exceed "20".

Set POWER switch to X10. Set TUNE/OPERATE switch to OPERATE. Slowly increase setting on SBE OUTPUT knob to bring power output reading up to desired level. Operate REACTANCE switch again to minimize WATTS-REFLECTED and VSWR readings. Lock SBE OUTPUT knob with LOCK disc. Set POWER switch to SHORT.

3-5. CW OPERATION

Install short across hand keyer. Tune up carrier per paragraph 3-4.

Remove short and operate hand keyer to transmit carrier.

3-6. SSB OPERATION

Tune up carrier per paragraph 3-4. Turn SBE OUTPUT knob down to 0.

Refer to SBE -8 Manual for SSB operation.

3-7. ISB OPERATION

Tune up carrier per paragraph 3-4. Turn SBE OUTPUT knob down to 0.

Refer to SBE manual for ISB operation.

3-8. AM OPERATION

Tune up carrier per paragraph 3-4. Turn SBE OUTPUT knob down to 0.

Refer to SBE manual for AM operation.

SECTION 4

PRINCIPLES OF OPERATION

4-1. GENERAL

The SBT-350 comprises nine major component units which, for easier understanding of the system operation, may be divided into three sub-systems: exciter, linear amplifier and antenna tuning.

The following text will discuss the principles of operation at a block diagram level, in reference to figure 4-1.

Refer to the individual component unit and sub-system technical manuals for detailed circuit analysis.

4-2. OVERALL FUNCTIONAL ANALYSIS

The exciter sub-system comprises the SBE exciter with its associated A-1397 power supply, VOX oscillator, and APP-5 power panel. The exciter sub-system is used to accept and translate the input intelligence to a desired operating frequency.

The input intelligence, applied at the APP-5, is routed to the input of the SBE exciter unit. The SBE accepts the input intelligence and develops it into either single, double or independent sideband transmission with various degrees of carrier insertion.

A continuously adjustable 2 to 4 mc injection frequency, derived from the VOX, provides for a multitude of carrier frequencies through the 1.75 to 32 mc frequency range. The exciter output, at its pre-selected frequency setting is routed to the linear amplifier sub-system.

Linear amplifier sub-system (PAL-350 C) comprises the RFA linear r-f amplifier, and its associated PSP power supply.

The RFA receives the exciter r-f output and amplifies it up to a 350 watts PEP level. Operating voltages for the RFA are supplied by the PSP power supply.

The power amplified r-f output from the linear amplifier sub-system is then made available to the antenna tuning sub-system.

Antenna tuning sub-system (ATS-2A) comprises the CU directional coupler (mounted as a part of AX650-2), MCU monitor control panel and TU antenna tuning and termination unit.

The r-f amplified output from the linear amplifier sub-system is applied to the CU directional coupler where it is routed out to the TU antenna tuner for antenna use. A portion of the r-f output is coupled from the CU to the MCU for forward and reflected power output monitoring. The MCU also receives hum, reactance and resistance readings from the TU antenna tuner.

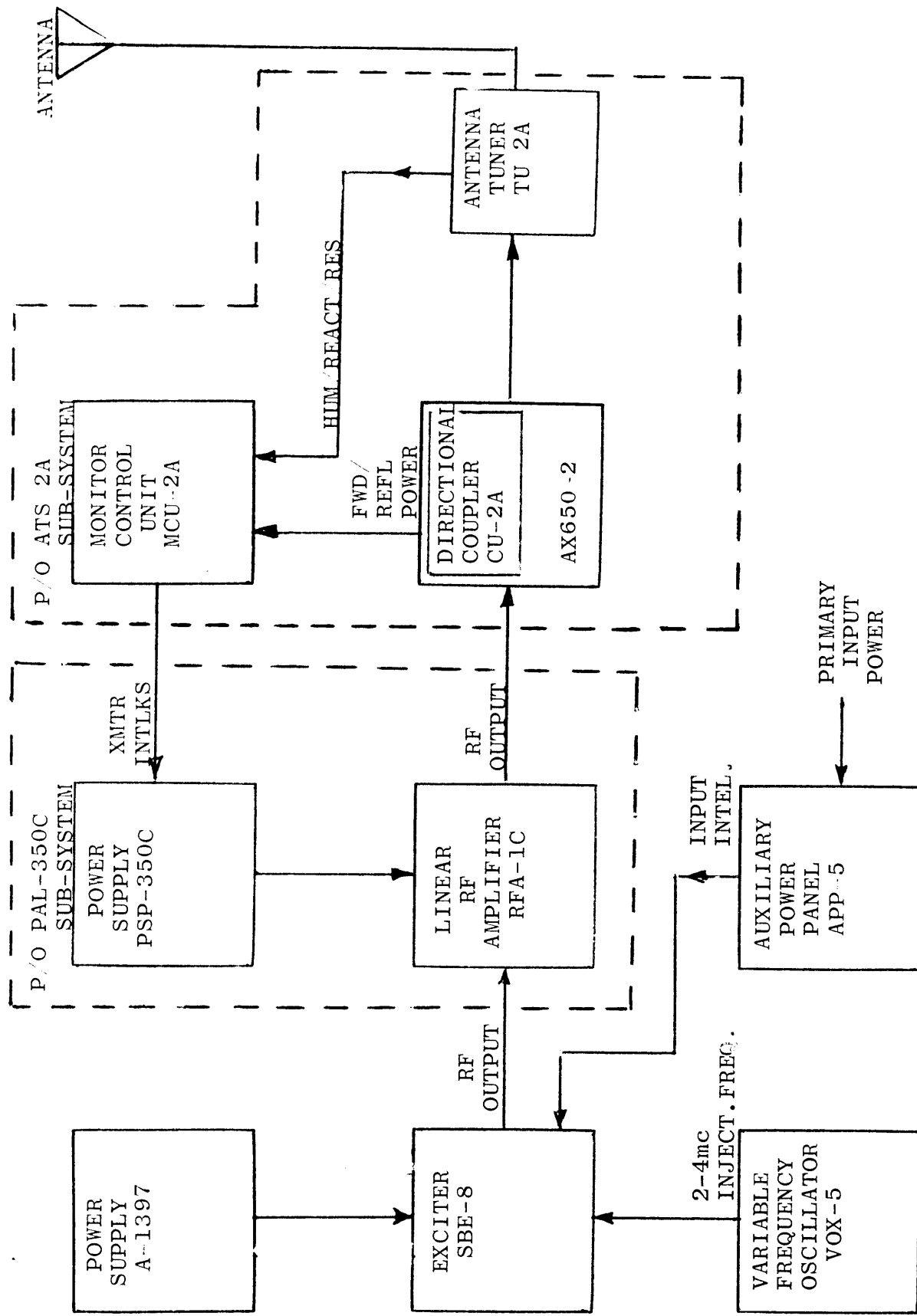

Figure 4-1. Simplified Block Diagram

SECTION 5

MAINTENANCE

5-1. PREVENTIVE MAINTENANCE.

In order to prevent equipment failure due to dust, dirt or other destructive elements, it is suggested that a schedule of preventive maintenance be set up and adhered to.

At periodic intervals, the equipment should be removed from its mounting for cleaning and inspection. The wiring and all components should be inspected for dirt, dust, corrosion, grease or other harmful conditions. Remove dust with a soft brush or vacuum cleaner. Remove dirt or grease with any suitable cleaning solvent. Use of carbon tetrachloride should be avoided due to its highly toxic effects. Trichlorethylene or methyl chloroform may be used, providing the necessary precautions are observed.

WARNING

When using toxic solvents, make certain that adequate ventilation exists. Avoid prolonged or repeated breathing of the vapor. Avoid prolonged or repeated contact with skin. Flammable solvents shall not be used on energized equipment or near any equipment from which a spark may be received. Smoking, "hot work", etc. is prohibited in the immediate area.

CAUTION

When using trichlorethylene, avoid contact with painted surfaces, due to its paint removing effects.

5-2. TROUBLESHOOTING

When a piece of equipment has been operating satisfactorily and suddenly fails, the cause of failure may be due to symptoms of past failures or due to component aging.

The first step in troubleshooting is to ascertain that proper equipment voltages are present, interconnecting cables are secure, and that all fuses are in functional condition.

NOTE

Never replace a fuse with one of a high rating unless brief continued operation is more important than probable equipment damage. If a fuse burns out immediately after replacement, do not replace it a second time until the cause has been located and corrected.

Visual troubleshooting of the modular unit chassis components and tube conditions may also help localize the fault. Refer to the individual modular unit technical manuals for associated unit troubleshooting procedures.

5-3. REPAIR AND REPLACEMENT

Maintenance of the SBT will consist mainly of component replacement. It should be noted that when replacing components having many wires connected, such as switches, relays, etc., the wires should be tagged and marked for accurate identification when replacing.

When replacing components, the technician should observe for exact or equivalent replacements by referring to the parts list of the appropriate modular unit technical manual.

Polarity and positioning of certain components should be observed before removing so that the replacement component will fit and operate correctly.

TABLE 5-1. TEST EQUIPMENT REQUIRED

| ITEM | MANUFACTURER |
|---------------------------|--|
| RF Spectrum Analyzer | TMC, Model PTE-4 or equivalent. |
| VTVM | Hewlett-Packard, Model 410B or equivalent. |
| Voltohmmeter | Simpson, Model 260 or equivalent. |
| Square Wave Generator | Boonton, Model 71 or equivalent. |
| 52-ohm dummy load, 500 w. | Any manufacturer meeting the necessary requirements. |
| Radio Receiver | TMC, Model GPR-90 or equivalent. |

5-4. OPERATIONAL CHECKS

The following checks are derived from factory test procedures, modified for field service use. Refer to table 5-1 for test equipment required.

WARNING

Voltages employed in the SBT system are high enough to be fatal. Every precaution should be taken by operating and maintenance personnel to minimize the danger of shock.

Remove all power during maintenance.

- a. With all system power switches set at OFF, connect a-c input power cable from SBT to primary a-c power source.
- b. Connect two-tone generator of PTE to channel 1 at rear of APP-5.
- c. Connect dummy load to SBT out put.

- d. Connect monitor jack of dummy load to PTE r-f input jack. Connect VTVM across load.
- e. Set MAIN POWER switch of APP-5 at ON. The red main power indicator lamp should light and rack blowers should operate.
- f. Set MAIN LINE switch of PSP-350 at ON. The main power indicator lamp should light and the RFA-1 blower should operate.

NOTE

The TRANSMITTER PLATE switch of the PSP-350 should be at STANDBY-REMOTE position. FINAL VOLTAGE switch should be at OFF and the OVER-LOAD breakers at ON.

- g. Set SBE power switch at ON. The red indicator lamp and oven indicator lamp on the power supply should light.
- h. Set VOX power switch at ON. The red main power indicator lamp; inner oven and outer oven lamps should light.
- j. After a warm-up period of approximately 5-minutes, set the TRANSMITTER VOLTAGE switch at ON. The red indicator lamp should light.
- k. Set the TRANSMITTER VOLTAGE switch at STANDBY.
- l. Set the XMIT toggle switch on the SBE at ON. The TRANSMITTER PLATES and HV LINE OVERLOAD indicator lamps on the PSP-350 should light.
- m. Set VOX meter at HFO position; HFO switch at ON.
- n. Set VOX master oscillator frequency.
- o. With SBE mid-frequency crystal switch set at VMO, adjust the SBE for two-tone test at required output frequency.
- p. Set OUTPUT control of SBE at zero.

- q. Set HV LINE switch of PSP-350 at ON. The red indicator lamp should light and the amber OVERLOAD indicator lamp should extinguish.
- r. Adjust the RFA 1 for 350 watts PEP at required frequency (132 VRMS across 52-ohms).
- s. Adjust the RFA-1 to obtain 40-db third order distortion at 350 watts PEP.
- t. Adjust the RFA-1 for 200 watts CW (100 VRMS at 52-ohms).
- u. Connect voltohmmeter across terminals 3 and 4 of E501 on the APP-5; meter should read 115 volts a-c, $\pm 10\%$.
- v. With voltohmmeter connected as in the preceding step, set XMTR and EXCITER switches on SBE at OFF. Volttohmmeter should read zero volts. HV LINE and TRANSMITTER PLATES indicator lamps should extinguish.
- w. Place a jumper wire across terminals 1 and 2 of E501 on APP-5. TRANSMITTER PLATES and HV LINE indicator lamps should light. Remove jumper.
- x. Place a jumper wire across terminals 9 and 10 of E501 on APP-5. TRANSMITTER VOLTAGES, FINAL VOLTAGES, and EXCITER ON indicator lamps should light. Remove jumper.
- y. Connect voltohmmeter across terminals 24 and 25 of E502 on APP-5. Meter should measure 10-ohms, $\pm 20\%$. Meter across terminals 23 and 24 should measure infinity.
- z. Place a jumper wire across terminals 9 and 10 of E501 on APP-5 to key the SBT. Volttohmmeter connected across terminals 23 and 24 of E502 on APP-5 should measure 10-ohms, $\pm 20\%$. Meter across terminals 24 and 25 should measure infinity.

The following test procedures are to ascertain proper SBT/receiver operation.

- a. Set test receiver to receive test frequency, with BFO switch at ON.
- b. Adjust SBT system for approximately 200 watts CW at test frequency using VSB channel 1 or channel 2.
- c. A keyed 1 KC tone should be heard at the receiver.
- d. Tune SBT system to 200 watts CW with VTVM. Measure the squelch output at the bottom of the AX650-2 by varying R2001. Meter should measure a negative voltage (0-20 VDC, $\pm 20\%$).
- e. Reduce SBT output to zero.

SECTION 6

PARTS LIST

6-1. INTRODUCTION

The parts list presented in this section is a cross-reference list of parts identified by a reference designation and TMC part number. In most cases, parts appearing on schematic diagrams are assigned reference designations in accordance with MIL-STD-16. Wherever practicable, the reference designation is marked on the equipment, close to the part it identifies. In most cases, mechanical and electro-mechanical parts have TMC part numbers stamped on them.

To expedite delivery when ordering any part, specify the following:

- a. Reference symbol.
- b. Description as indicated in parts list.
- c. TMC part number.
- d. Model and serial numbers of the equipment containing the part being replaced; this can be obtained from the equipment nameplate.

For replacement parts not covered by warranty (refer to warranty sheet in front of manual), address all purchase orders to:

The Technical Materiel Corporation
Attention: Sales Department
700 Fenimore Road
Mamaroneck, New York

Parts List
for
Cabinet, Electrical Equipment, RAK-19K

| REF SYMBOL | DESCRIPTION | TMC PART NUMBER |
|---------------|----------------|--------------------|
| | TO BE SUPPLIED | |