

NOTICE

THE CONTENTS AND INFORMATION CONTAINED IN THIS INSTRUCTION MANUAL IS PROPRIETARY TO THE TECHNICAL MATERIEL CORPORATION TO BE USED AS A GUIDE TO THE OPERATION AND MAINTENANCE OF THE EQUIPMENT FOR WHICH THE MANUAL IS ISSUED AND MAY NOT BE DUPLICATED EITHER IN WHOLE OR IN PART BY ANY MEANS WHATSOEVER WITHOUT THE WRITTEN CONSENT OF THE TECHNICAL MATERIEL CORPORATION.



THE TECHNICAL MATERIEL CORPORATION

C O M M U N I C A T I O N S E N G I N E E R S

700 FENIMORE ROAD

MAMARONECK, N. Y.

W a r r a n t y

The Technical Materiel Corporation, hereinafter referred to as TMC, warrants the equipment (except electron tubes,*fuses, lamps, batteries and articles made of glass or other fragile or other expendable materials) purchased hereunder to be free from defect in materials and workmanship under normal use and service, when used for the purposes for which the same is designed, for a period of one year from the date of delivery F.O.B. factory. TMC further warrants that the equipment will perform in a manner equal to or better than published technical specifications as amended by any additions or corrections thereto accompanying the formal equipment offer.

TMC will replace or repair any such defective items, F.O.B. factory, which may fail within the stated warranty period, PROVIDED:

1. That any claim of defect under this warranty is made within sixty (60) days after discovery thereof and that inspection by TMC, if required, indicates the validity of such claim to TMC's satisfaction.
2. That the defect is not the result of damage incurred in shipment from or to the factory.
3. That the equipment has not been altered in any way either as to design or use whether by replacement parts not supplied or approved by TMC, or otherwise.
4. That any equipment or accessories furnished but not manufactured by TMC, or not of TMC design shall be subject only to such adjustments as TMC may obtain from the supplier thereof.

Electron tubes*furnished by TMC, but manufactured by others, bear only the warranty given by such other manufacturers. Electron tube warranty claims should be made directly to the manufacturer of such tubes.

TMC's obligation under this warranty is limited to the repair or replacement of defective parts with the exceptions noted above.

At TMC's option any defective part or equipment which fails within the warranty period shall be returned to TMC's factory for inspection, properly packed with shipping charges prepaid. No parts or equipment shall be returned to TMC, unless a return authorization is issued by TMC.

No warranties, express or implied, other than those specifically set forth herein shall be applicable to any equipment manufactured or furnished by TMC and the foregoing warranty shall constitute the Buyers sole right and remedy. In no event does TMC assume any liability for consequential damages, or for loss, damage or expense directly or indirectly arising from the use of TMC Products, or any inability to use them either separately or in combination with other equipment or materials or from any other cause.

*Electron tubes also include semi-conductor devices.

PROCEDURE FOR RETURN OF MATERIAL OR EQUIPMENT

Should it be necessary to return equipment or material for repair or replacement, whether within warranty or otherwise, a return authorization must be obtained from TMC prior to shipment. The request for return authorization should include the following information:

1. Model Number of Equipment.
2. Serial Number of Equipment.
3. TMC Part Number.
4. Nature of defect or cause of failure.
5. The contract or purchase order under which equipment was delivered.

PROCEDURE FOR ORDERING REPLACEMENT PARTS

When ordering replacement parts, the following information must be included in the order as applicable:

1. Quantity Required.
2. TMC Part Number.
3. Equipment in which used by TMC or Military Model Number.
4. Brief Description of the Item.
5. The *Crystal Frequency* if the order includes crystals.

PROCEDURE IN THE EVENT OF DAMAGE INCURRED IN SHIPMENT

TMC's Warranty specifically excludes damage incurred in shipment to or from the factory. In the event equipment is received in damaged condition, the carrier should be notified immediately. Claims for such damage should be filed with the carrier involved and not with TMC.

All correspondence pertaining to Warranty Claims, return, repair, or replacement and all material or equipment returned for repair or replacement, within Warranty or otherwise, should be addressed as follows:

THE TECHNICAL MATERIEL CORPORATION
Engineering Services Department
700 Fenimore Road
Mamaroneck, New York

CHANGE NO. 1



INSTRUCTION BOOK CHANGE NOTICE

Date October 8, 1963

Manual affected: Sideband Converter SBC-1 and SBC-2 IN -4003/257

(a) Page I-1-4

Change specifications for Input Power to the SBC-1 to read:
"The power input requirements for the Model SBC-1 with all
ovens on are as follows:

<u>A.C. Line Voltage</u>	<u>Power</u>
105 volts	300 watts
117 volts	360 watts
129 volts	430 watts

(b) Page I-6-1/I-6-2

Add to paragraph 1-6-1 Operator's Maintenance
"The equipment requires a minimum of a two hour warm-up
before it will stabilize. Non-operating controls should
not be tampered with unless it is determined that the
unit is not stable or the oscillators are not on frequency
after this warm-up."

(c) All reference to Automatic Frequency Control
AFC-2 should be changed to AFC-2A.

SHOULD ADDITIONAL COPIES OF THIS CHANGE NOTICE BE REQUIRED, PLEASE CONTACT:

THE TECHNICAL MATERIEL CORP., 700 Fenimore Road, Mamaroneck, New York

Attn.: Director of Eng. Services.

FOREWORD

The models SBC feature newly developed electronic circuits packaged on a building block principle to provide maximum flexibility. The model SBC-1 consists of two major rack mounting units: the model AFC-2, Automatic Frequency Control, and the model SBS-1, Sideband Selector. The model SBC-2 adds a third unit, the model RMX-2 Demultiplexer - consisting of two model RMX-1 Demultiplexers. To satisfy the requirements for manuals most practically, individual manuals on each unit are written; then the manuals are combined as required to cover either the SBC-1 or the SBC-2.

The following colloquial terms are used in this preliminary manual to simplify formal nomenclature terminology:

FORMAL	COLLOQUIAL
Sideband Converter Models SBC-1 and SBC-2	SBC-1 and SBC-2
Automatic Frequency Control Model AFC-2	AFC-2
Sideband Selector Model SBS-1	SBS-1
Demultiplexer Model RMX-2	RMX-2
Demultiplexer Model RMX-1 (TD-411/UGC)	RMX-1

Either model SBC may be used with an appropriate Communications Receiver and carrier terminal equipment such as the AN/FGC-29, AN/FGC-61, or TMC model TTS.

**TABLE OF CONTENTS OF SIDEBAND CONVERTER
MODELS SBC-1 AND SBC-2**

Part	Title	Part	Title
I	GENERAL DESCRIPTION OF SIDEBAND CONVERTER MODELS SBC-1 AND SBC-2	IV	TECHNICAL MANUAL FOR DEMULTIPLEXER MODELS RMX-1 AND RMX-2
II	TECHNICAL MANUAL FOR SIDEBAND SELECTOR MODEL SBS-1	V	APPENDIX - RACK AND ACCESSORIES
III	TECHNICAL MANUAL FOR AUTO- MATIC FREQUENCY CONTROL MODEL AFC-2		

TABLE OF CONTENTS OF PART I
(GENERAL DESCRIPTION OF SIDEBAND CONVERTER
MODELS SBC-1 AND SBC-2)

SECTION 1—GENERAL DESCRIPTION

Paragraph		Page
I-1-1	Functional Description of Sideband Converter Models SBC-1 and SBC-2	I-1-1
I-1-2	Technical Specifications of AFC-2 and SBS-1	I-1-2
I-1-3	Technical Specifications of RMX-2 (Two RMX-1 Units)	I-1-4

SECTION 2—INSTALLATION

I-2-1	General	I-2-0
I-2-2	Production Line Checkout	I-2-0
I-2-3	Installation Layout	I-2-0
I-2-4	Inspection and Initial Adjustments	I-2-0

SECTION 3—OPERATOR'S SECTION

I-3-1	General	I-3-1
I-3-2	Operation of SBC-1	I-3-1
	a. AFC-2 Unit	I-3-1
	b. SBS-1 Unit	I-3-1
I-3-3	Operation of SBC-2	I-3-3
	a. AFC-2 Unit	I-3-3
	b. SBS-1 Unit	I-3-3
	c. RMX-1 Unit	I-3-3

SECTION 4—PRINCIPLES OF OPERATION

I-4-1	General	I-4-1
	a. Automatic Phase Control System	I-4-1
	b. Phase Detector Circuit	I-4-1
I-4-2	Sideband Selector SBS-1	I-4-2
I-4-3	Automatic Frequency Control AFC-2	I-4-9

SECTION 5—TROUBLE-SHOOTING

Paragraph		Page
I-5-1	General	I-5-0
I-5-2	Trouble-Shooting Techniques	I-5-0
	a. General Considerations	I-5-0
	b. Trouble-Shooting Charts Based on Operating Procedures	I-5-0
	c. Tables of Voltage and Resistance; Waveform Data	I-5-0
	d. Trouble-Shooting Procedures Based on Circuit Sectionalization	I-5-0

SECTION 6—MAINTENANCE

I-6-1	Operator's Maintenance	I-6-1/I-6-2
I-6-2	Preventive Maintenance	I-6-1/I-6-2
	a. Once each shift during an "on the air" period	I-6-1/I-6-2
	b. Daily during an "off the air" period	I-6-1/I-6-2
	c. Monthly during "off the air" periods	I-6-1/I-6-2
I-6-3	Corrective Maintenance	I-6-1/I-6-2

SECTION 7—PARTS LIST

See Sections 7 of Parts II, III and IV

SECTION 8—SCHEMATIC DIAGRAMS

See Sections 8 of Parts II, III and IV

LIST OF ILLUSTRATIONS

SECTION 1—GENERAL DESCRIPTION		SECTION 4—PRINCIPLES OF OPERATION	
Figure	Page	Figure	Page
I-1-1a	Front Angle View of Sideband Converter Model SBC-1 v	I-4-1	Block Diagram of an Automatic Control Circuit I-4-1
I-1-1b	Front Angle View of Sideband Converter Model SBC-2 vi	I-4-2	Simplified Schematic Diagram Illustrating Operation of Phase-Detector Circuit Used in SBC I-4-2
I-1-2	Functional Illustration, SBC-1 . . . I-1-1	I-4-3	Block Diagram, Sideband Selector SBS-1 I-4-3/I-4-4
I-1-3	Differences Between SBC-1 and SBC-2 I-1-2	I-4-4	Block Diagram, Automatic Frequency Control AFC-2 I-4-7/I-4-8
SECTION 3—OPERATOR'S SECTION			
I-3-1	Location of Controls I-3-4		

LIST OF TABLES

SECTION 3—OPERATOR'S SECTION	
Table	Page
I-3-1	Table of Equivalent Control Designations I-3-5

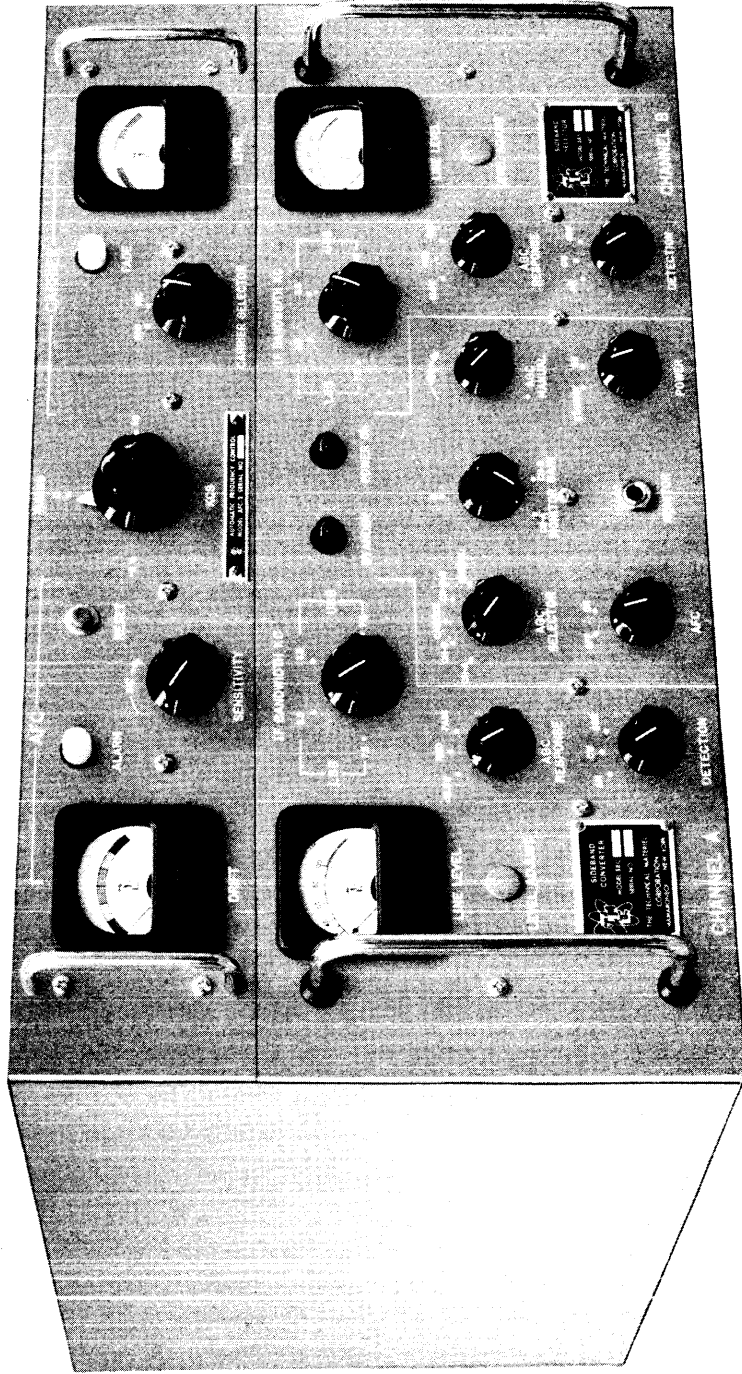

Figure I-1-1a. Front Angle View of Sideband Converter Model SBC-1

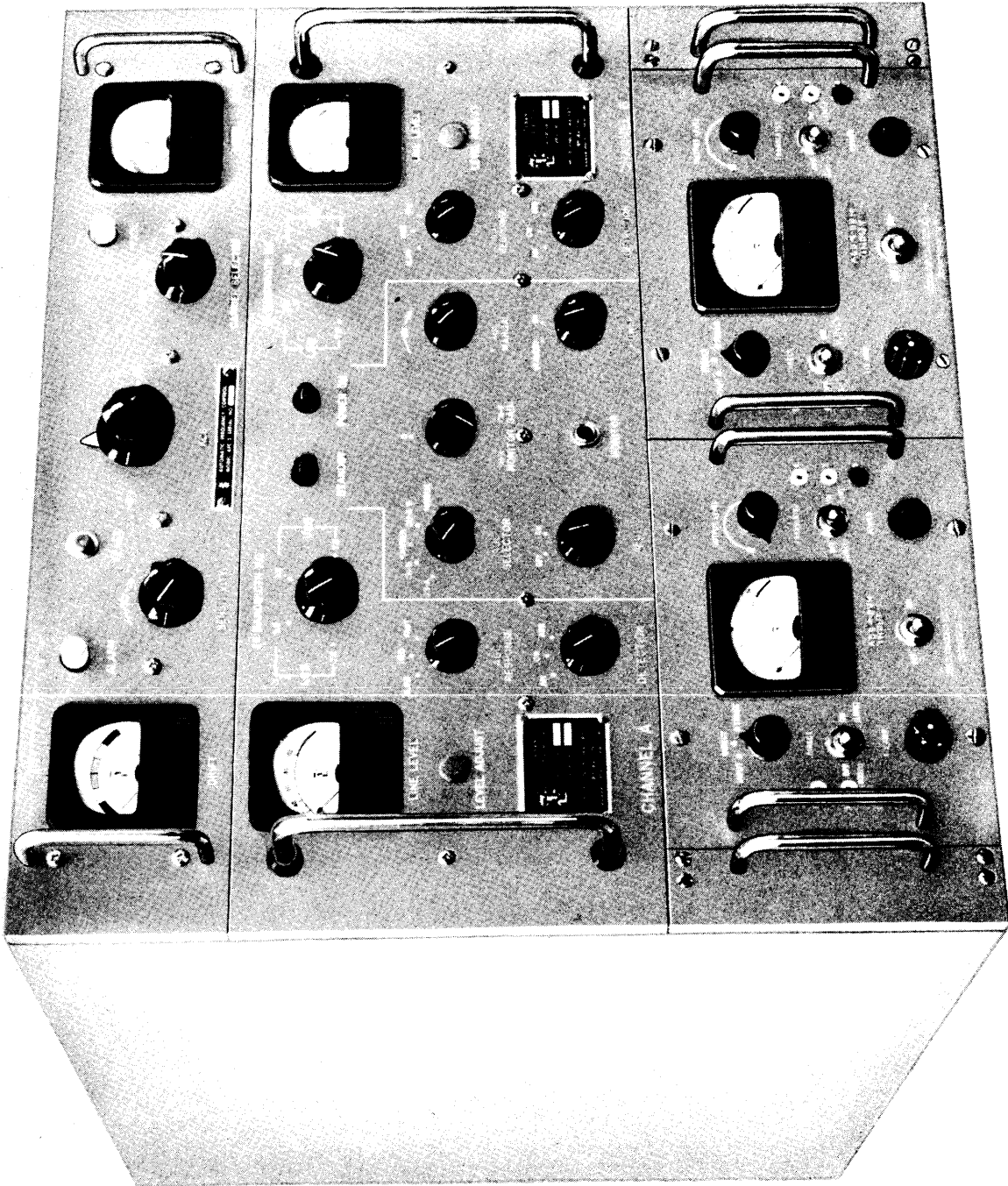

Figure I-1-1b. Front Angle View of Sideband Converter Model SBC-2

SECTION 1 GENERAL DESCRIPTION

I-1-1. FUNCTIONAL DESCRIPTION OF SIDEBAND CONVERTER MODELS SBC-1 AND SBC-2.

(See figures I-1-1a and I-1-1b.)

The TMC Model SBC sideband converters are IF type receiving adapters that will provide optimum reception of single, double, or independent sideband signals, with or without automatic frequency control. The AFC will function with up to 20-db carrier suppression and may be disabled for the reception of fully suppressed carrier signals.

The Model SBC-1 provides two discrete audio output channels for independent sideband operation. The Model SBC-2 incorporates a dual-voice-frequency demultiplexer, TMC Model RMX-2 (consisting of two demultiplexers, TMC Model RMX-1), which provides four 3-kc outputs for independent sideband multiplex operation.

Figure I-1-2 functionally illustrates how the SBC-1 performs. The receiver's IF (midfrequency $f_0 = 455\text{kc}$) with upper and lower sidebands is fed to the SBS's mixer. AFC-2's 705-kc reactance oscillator is also fed to the SBS's mixer. The 250-kc difference frequency (with upper and lower sidebands removed by 250.050-249.950 band pass filter is fed to the phase detector. The phase detector also receives the output of AFC-2's 250-kc reactance oscillator. The d-c output of the phase detector controls both reactance oscillators so that the midfrequencies of the product detector's 250-kc inputs are identical. Selector switches (not shown) in the SBS unit provide the SBS with four audio outputs: (a) upper sideband, 3.5kc; (b) lower sideband, 3.5kc; (c) upper side band, 7.5kc; and (d) lower sideband, 7.5kc.

Figure I-1-3 illustrates the differences between the SBC-1 and SBC-2 units.

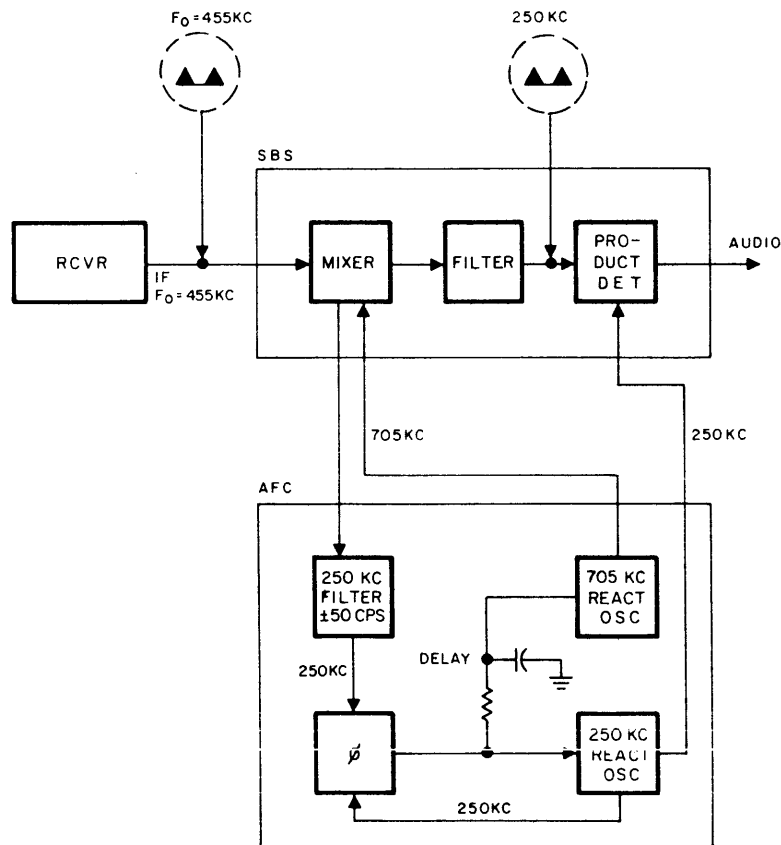

Figure I-1-2. Functional Illustration, SBC-1

AGC SYSTEM:	The SBC's have provisions to control the receiver gain from an AGC voltage derived from upper sideband, lower sideband, or carrier. The AGC system has a fast attack time and an adjustable release time.
IF BANDWIDTHS:	<p>A. Normally supplied:</p> <ol style="list-style-type: none"> 1. ± 1.5-db 250- to 7500-cps, USB 2. ± 1.5-db 250- to 7500-cps, LSB 3. ± 1.5-db 250- to 3300-cps, USB 4. ± 1.5-db 250- to 3300-cps, LSB <p>B. Available on special order:</p> <ol style="list-style-type: none"> 1. ± 1.5-db 250- to 6000-cps, USB 2. ± 1.5-db 250- to 6000-cps, LSB 3. ± 1.5-db 1-kc, symmetrical 4. ± 1.5-db 6-kc, symmetrical 5. ± 1.5-db 15-kc, symmetrical
AFC ACCURACY:	Less than 1-cycle error over the entire AFC control.
AFC CHARACTERISTICS:	The AFC system will synchronize with a 20-db suppressed carrier that has an error of ± 50 cps and will follow a maximum drift rate of ± 10 cps/second. The system will stay synchronized over a minimum frequency range of $\pm 1,000$ cps from the center frequency.
DRIFT ALARM:	A drift alarm light indicates when the carrier error is greater than ± 750 cps.
FADE ALARM:	The fade alarm provides a visual indication when the carrier is interrupted or fades below a predetermined level.
SENSITIVITY:	A continuously adjustable sensitivity control (squelch) is provided on the front panel to reduce the system sensitivity when excess noise is encountered.
AUDIO OUTPUTS:	<p>A. High Level: Two 0- to 1-watt balanced 600-ohm audio channels.</p> <p>B. Low Level: Two 0- to 1-milliwatt balanced 600-ohm audio channels.</p>
AUDIO RESPONSE:	The amplitude response of the audio amplifier is ± 1.5 db over the frequency range of 100 to 22,000 cps.
AUDIO DISTORTION:	-45 db.
METERING:	<p>A. Independent meters are provided to monitor each low-level 600-ohm channel.</p> <p>B. AFC drift alarm indicator.</p> <p>C. Carrier fade indicator.</p>
MONITORING:	A separate monitoring circuit is provided to permit headphone monitoring of either audio channel without disturbing the audio output circuits.
HUM OUTPUT:	-50 db.
ENVIRONMENT:	Designed for continuous duty within a temperature range of 0 to 50 degrees C and any value of humidity up to 90%.

ORIENTATION:	Any.
INPUT POWER:	SBC-1: 115/230 volts ac, 50/60 cps, single phase, approximately 100 watts (400 cps optional on special order). SBC-2: 115/230 volts ac, 50/60 cps, single phase, approximately 108 watts (400 cps optional on special order). SBC-1: 10-1/2" h x 19" w x 17" d. AFC-2: 3-1/2" h x 19" w x 17" d. SBS-1: 7" h x 19" w x 17" d. SBC-2: 15-3/4" h x 19" w x 17" d. AFC-2: 3-1/2" h x 19" w x 17" d. SBS-1: 7" h x 19" w x 17" d. RMX-2: 5-1/4" h x 19" w x 11-1/2" d.
INSTALLED WEIGHT (Approx.):	SBC-1: 50 lb. SBC-2: 72 lb.
SHIPPING WEIGHT AND CUBE (Approx.):	SBC-1: 85 lb., 6.3 cu ft. SBC-2: 120 lb., 11.8 cu ft.
COMPONENTS AND CONSTRUCTION:	All equipment manufactured in accordance with JAN/MIL specifications wherever practicable.

I-1-3. TECHNICAL SPECIFICATIONS OF RMX-2 (TWO RMX-1 UNITS).

NUMBER OF INPUTS:	Two.
INPUT BANDWIDTH:	375 to 5915 cps.
INPUT IMPEDANCE:	600 ohms balanced.
NUMBER OF OUTPUTS:	Four.
OUTPUT BANDWIDTHS:	375 to 3025 cps (per channel).
OUTPUT IMPEDANCE:	600 ohms balanced.
INPUT LEVEL	
TELEPHONE:	-15 to +4 dbm.
FACSIMILE:	-15 to +4 dbm.
TELEGRAPH (16 channel):	-25 to +4 dbm per channel.
NOMINAL OUTPUT LEVELS	
TELEPHONE:	-4 dbm.
FACSIMILE:	0 dbm.
TELEGRAPH (16 channel):	-10 dbm per channel.
MAXIMUM OUTPUT LEVEL:	+16 dbm (single frequency).
INTERNAL CARRIER STABILITY:	Approximately 1 part in 1, 000, 000 per degree C.

INTERNAL CARRIER
ACCURACY:

Within 0.1 cps at 6290 cps.

METERING:

Two meters. Switchable to either input or output channels.

POWER REQUIREMENTS:

115/230 volts ac, 50/60 cps, single phase, approximately 8 watts (400 cps optional on special order).

DIMENSIONS:

5-1/4" h x 19" w x 11-1/2" d.

WEIGHT:

Approximately 22 lb.

TRANSISTOR COMPLEMENT:

15 each 2N414 or equivalent.
4 each 2N156 or equivalent.
3 each 2N1284 or equivalent.

COMPONENTS:

All equipment is manufactured in accordance with JAN/MIL specifications wherever practicable.

SECTION 2 INSTALLATION

I-2-1. GENERAL.

The SBC-1 and SBC-2 equipments are shipped in wooden crates. On arrival, uncrate the equipments and carefully inspect for damage. If any damage is found, notify the carrier or supply department immediately. Inspect all packing for parts shipped as loose items.

The contents of SBC cases are packed according to military specifications. All SBC-1 and SBC-2 equipments are wrapped individually to avoid being scratched, are placed in cartons that are cushioned against shock, and are wrapped and sealed with waterproof material within which the units are kept dry with a dessicant.

I-2-2. PRODUCTION LINE CHECKOUT.

Before any SBC equipment is shipped, it has been assembled on the test floor and thoroughly checked against the manufacturer's test specifications. This procedure eliminates assembly line errors and guarantees that an SBC equipment will fully satisfy all design requirements. After this thorough checkout, the

SBC is packed for customer use. The packaging operations, in turn, are such as to minimize troubles that may develop in transit.

I-2-3. INSTALLATION LAYOUT.

The SBC is used in combination with other equipments, as explained in paragraph I-1-1. Where associated equipments are rack mounted, the SBC units are provided with slides for rack mounting. The SBC does not have a rack of its own.

The SBC's power supply assembly is designed for 115- or 230-volt, 50- or 60-cps, single phase power; it is factory wired for 115 volts. If 230-volt operation is required, minor wiring changes to the power supply assembly are necessary.

I-2-4. INSPECTION AND INITIAL ADJUSTMENTS.

Make certain that all connections are properly made. No initial adjustment of the SBC is required. Refer to Sections 3 and 6 of Parts II, III, and IV for operation and adjustment sequences for the equipment.

SECTION 3 OPERATOR'S SECTION

I-3-1. GENERAL.

This section assumes that all subassemblies of SBC-1 and SBC-2 are in proper working condition, capable of performing their normal functions, and properly powered and interconnected.

I-3-2. OPERATION OF SBC-1. (See figure I-3-1 and table I-3-1.)

a. AFC-2 UNIT.

Step	Control	Operation	Purpose
1	TUNING (KCS) control (4)	Position for tuning	Centers AFC-2 drift meter
2	CARRIER SELECTOR switch (7)	Position at RCC or OSC as desired	Selects source of 250-kc AFC output
3	AFC SENSITIVITY control (8)	Position for desired sensitivity of AFC-2	Permits adjustment of AFC-2 sensitivity
4	CARRIER LEVEL meter (6)	Observe 250-kc carrier level	Permits determination of 250-kc carrier level
5	AFC DRIFT meter (1)	Observe AFC drift	Permits determination of AFC drift
6	CARRIER FADE indicator (5)	Observe carrier fade	Lights when carrier fades excessively
7	AFC DRIFT ALARM indicator (2)	Observe AFC drift	Lights when AFC drifts excessively
8	AFC RESET push button (3)	Push as AFC-2 is tuned	Facilitates tuning AFC-2 for center frequency

b. SBS-1 UNIT.

Step	Control	Operation	Purpose
1	POWER switch (20)	Turn ON (POWER ON indicator (14) lights; STANDBY indicator (13) goes out)	Energizes SBC
2a, b	a. CHANNEL A IF BANDWIDTH KC switch (12)	Turn to desired channels and bandwidths	Determines audio channels and bandwidths

b. SBS-1 UNIT. (Cont.)

Step	Control	Operation	Purpose
	b. CHANNEL B IF BANDWIDTH KC switch (15)	Turn to desired channels and bandwidths	Determines audio channels and bandwidths
3	AFC switch (24)	Turn to ON	Channels 705-kc output of AFC-2 unit to mixer of SBS-1 (6S4) and 250-kc output to product detectors
4a, b	a. CHANNEL A DETECTION switch (26) b. CHANNEL B DETECTION switch (19)	Turn to desired mode of transmission	Channels AM or product detector's output to audio output
5a, b	a. CHANNEL A AGC RESPONSE switch (11) b. CHANNEL B AGC RESPONSE switch (16)	Normally turn to MED NOTE On fast deep fades, AGC RESPONSE switches may require adjustment to maintain constant readings on CHANNEL A LINE LEVEL meter (9) and CHANNEL B LINE LEVEL meter (17)	
6	MONITOR GAIN control (23)	Turn clockwise or counterclockwise from 0	Alters gain on phones plugged into MONITOR jack (22)
7a, b	a. CHANNEL A LEVEL ADJUST control (10) b. CHANNEL B LEVEL ADJUST control (18)	Turn screwdriver adjustment in order to zero CHANNEL A LINE LEVEL meter (9) on zero input Turn screwdriver adjustment in order to zero CHANNEL B LINE LEVEL meter (17) on zero input	Line level meters track audio levels
8	AGC SELECTOR switch (25)	Select channel to provide AGC: Set at CH-A when channel A only is in use; set at CH-B when channel B only is in use; set at CARRIER when carrier is strong; set at CH-A-B when both channels are in use; if manual AGC is desired, set at MANUAL and operate AGC MANUAL control (21)	Modifies AGC action

I-3-3. OPERATION OF SBC-2. (See figure I-3-1.)

a. AFC-2 UNIT.

(Same as subsection a, paragraph I-3-2)

b. SBS-1 UNIT.

(Same as subsection b, paragraph I-3-2)

c. RMX-1 UNIT.

Step	Control	Operation	Purpose
1	POWER indicator (35)	Observe	Indicates that main power is supplied to RMX-1
2	INPUT switch (36)	Turn ON	Applies input signal to RMX-1
3a, b	a. DIRECT channel switch (28) b. TRANSLATED channel switch (30)	Turn ON Turn ON	Provides direct channel output of RMX-1 Provides translated channel output of RMX-1
4	Meter switch (27)	Turn to INPUT, DIRECT, or TRANS to monitor input or outputs on meter (29)	Connects input, direct output, or translated output of RMX-1 to meter for level monitoring

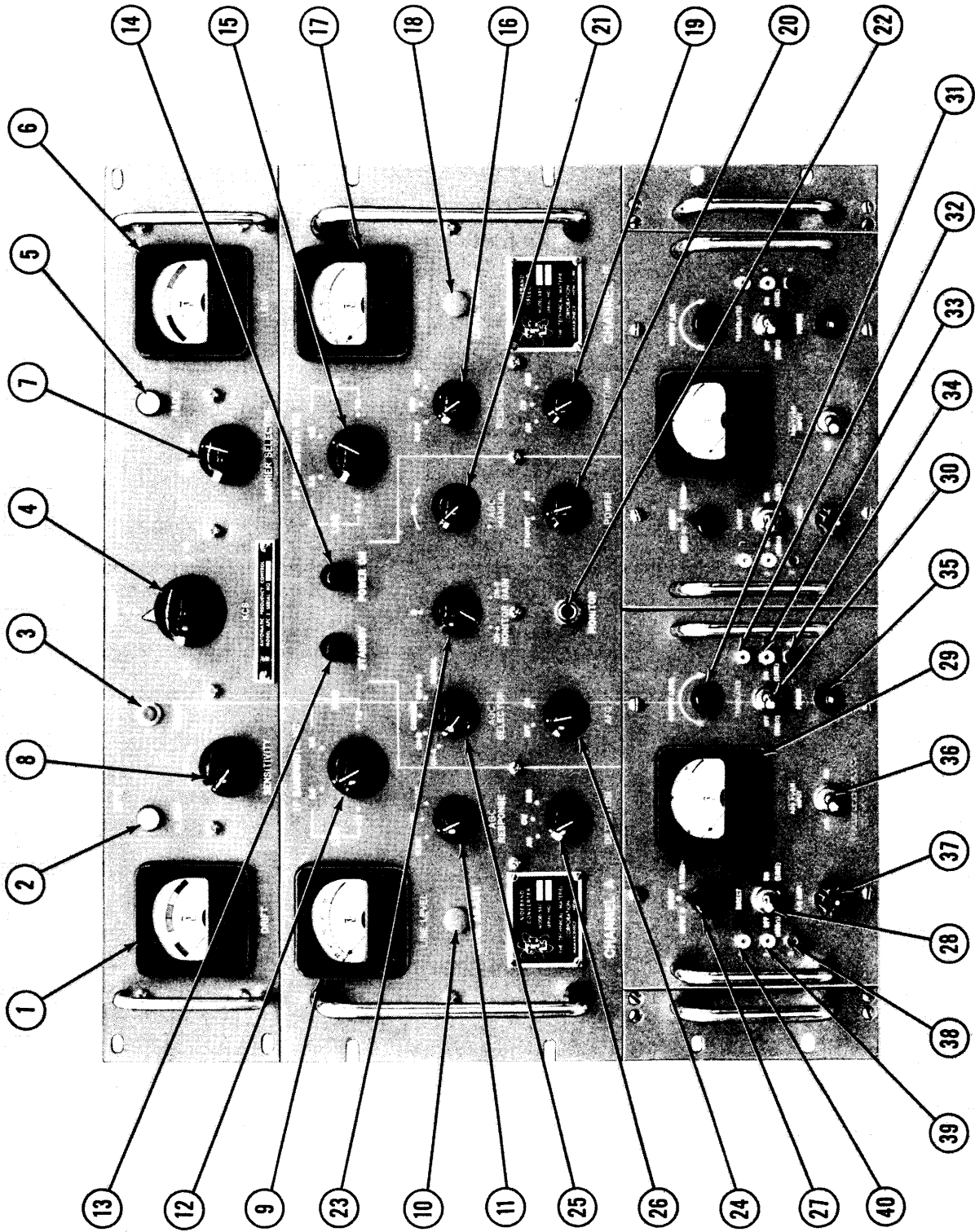

Figure I-3-1. Location of Controls

TABLE I-3-1. TABLE OF EQUIVALENT CONTROL DESIGNATIONS

Serial Designation (Figure I-3-1)	Panel Designation (Figure I-3-1)	Component Reference Designation on Overall Schematics (See Parts II, III, and IV, Sections 8, respectively)
1	AFC DRIFT meter	M5001
2	AFC DRIFT ALARM indicator	I5000
3	AFC RESET push button	S5001
4	TUNING (KCS) control	C5096
5	CARRIER FADE indicator	I5001
6	CARRIER LEVEL meter	M5000
7	CARRIER SELECTOR switch	S5000
8	AFC SENSITIVITY control	R5024
9	CHANNEL A LINE LEVEL meter	M6200
10	CHANNEL A LEVEL ADJUST control	R6237
11	CHANNEL A AGC RESPONSE switch	S6203
12	CHANNEL A IF BANDWIDTH KC switch	S6201
13	STANDBY indicator	I6200
14	POWER ON indicator	I6201
15	CHANNEL B IF BANDWIDTH KC switch	S6202
16	CHANNEL B AGC RESPONSE switch	S6204
17	CHANNEL B LINE LEVEL meter	M6201
18	CHANNEL B LEVEL ADJUST control	R6234
19	CHANNEL B DETECTION switch	S6205
20	POWER switch	S6208

TABLE I-3-1. TABLE OF EQUIVALENT CONTROL DESIGNATIONS (Cont.)

Serial Designation (Figure I-3-1)	Panel Designation (Figure I-3-1)	Component Reference Designation on Overall Schematics (See Parts II, III, and IV, Sections 8, respectively)
21	AGC MANUAL control	R6233
22	MONITOR jack	J6202
23	MONITOR GAIN control	R6244
24	AFC switch	S6200
25	AGC SELECTOR switch	S6207
26	CHANNEL A DETECTION switch	S6206
27	Meter switch	S3
28	DIRECT channel switch	S2
29	Meter	M1
30	TRANSLATED channel switch	S4
31	OUTPUT LEVEL control	R1
32	4 jack (TP4)	
33	5 jack (TP5)	
34	6 jack (TP6)	
35	POWER indicator	I1
36	INPUT switch	S1
37	FUSE	F1
38	3 jack (TP3)	
39	2 jack (TP2)	
40	1 jack (TP1)	

SECTION 4

PRINCIPLES OF OPERATION

I-4-1. GENERAL.

As indicated in the Table of Contents of this manual, the SBC is described in Parts I through IV as follows:

Part	Section	Description
I	4	By block diagrams of basic equipment units.
II	4	By stage-by-stage simplified schematics of SBS-1 unit.
III	4	By stage-by-stage simplified schematics of AFC-2 unit.
IV	4	By stage-by-stage simplified schematics of RMX-1 and RMX-2 units.

Parts II, III and IV, Section 8, present schematic diagrams of overall equipment units. The block diagram descriptions in Part I present a quick overall picture of the functioning of each unit. However, to facilitate understanding, some general remarks are pertinent.

a. AUTOMATIC PHASE CONTROL SYSTEM.

As shown in figure I-4-1, this system contains an oscillator with a nominal frequency equal to the desired output frequency, some form of reactance modulator or other means of voltage control of the oscillator frequency, a phase detector that compares the outputs of the oscillator and the reference source, and a low-pass filter that filters the output voltage of

the phase detector before it is applied to the reactance modulator.

The operation of the system can be understood qualitatively by assuming that the oscillator frequency is equal to that of the reference. The phase-detector output is then a d-c voltage depending on the phase difference between the output signals of the oscillator and the reference. This voltage is applied through the low-pass filter to the reactance modulator, thereby governing the oscillator frequency. If the oscillator frequency tends to change, this attempted change is first felt as a phase-difference change in the phase detector. This produces a change in phase-detector output voltage which acts to hold the oscillator frequency constant. As the oscillator drifts, its output phase, (relative to that of the reference) will drift but its average frequency will remain fixed. The system operates exactly like a positional servo mechanism wherein, for constant input position, the output position is exactly equal to the input, with zero steady-state error.

b. PHASE DETECTOR CIRCUIT.

As shown in figure I-4-2, voltage V_1 produces voltage E_1 across potentiometer R . When terminal 3 is positive relative to terminal 4, the diodes conduct and present relatively low impedance; when terminal 3 is negative relative to terminal 4, the diodes are non-conducting and present a very high impedance. This aspect is pictured in the top graph of I-4-2.

Now, let V_2 's frequency be the same as V_1 's frequency but V_2 's phase be 90 degrees behind V_1 's phase. For clarity, V_2 's zero axis (figure I-4-2) is displaced below V_1 's zero axis. During the first and third half cycles of V_1 , V_2 "sees" G through the relatively low impedance of the diodes. During the second and fourth half cycles of V_1 , V_2 "sees" G through

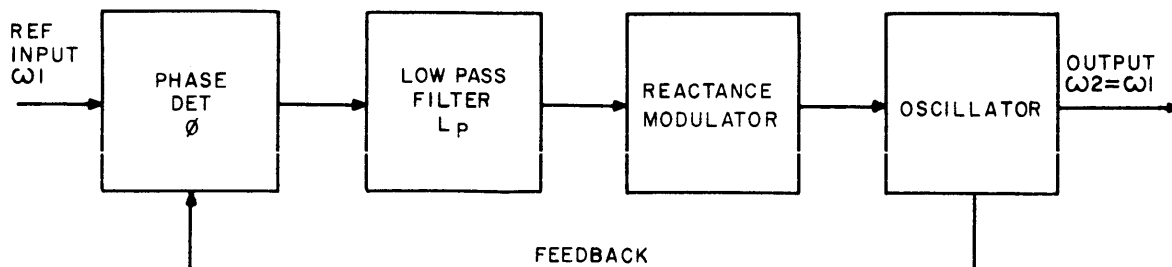

Figure I-4-1. Block Diagram of an Automatic Control Circuit

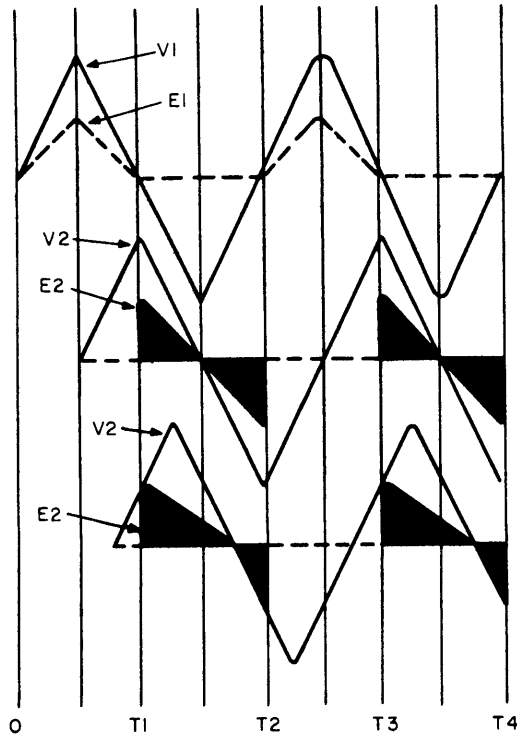
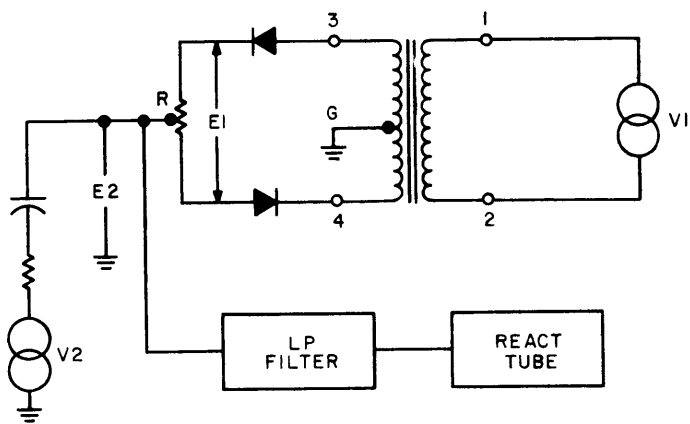

Figure I-4-2. Simplified Schematic Diagram Illustrating Operation of Phase-Detector Circuit Used in SBC

the very high impedance of the diodes. The wave shape of E2 is as shown with equal positive and negative areas of voltage at the LP filter's input. To obtain graph E2, pictured as the second graph of figure I-4-2, note that when the diodes are conducting, V2's external impedance "consumes" most of the voltage, leaving E2 negligibly small; however, when the diodes are non-conducting, E2 becomes relatively large.

Now, let V2's frequency be the same as V1's frequency but V2's phase be 135 degrees behind V1's phase. For clarity, V2's zero axis is further displaced below V1's zero axis. Again, during times 0 T₁ and T₂ T₃, when the diodes are conducting, the value of E2 is substantially zero. During times T₁ T₂ and T₃ T₄, when the diodes are non-conducting, the value of E2 is positive or negative depending upon phase. The waveform of E2 is as shown with unequal positive and negative areas of voltage at the LP filter's input.

I-4-2. SIDEBAND SELECTOR SBS-1.

(See figure I-4-3.)

As shown in figure I-1-3, the sideband selector is a device that receives an associated receiver's IF and supplies selected sideband audio. In combination with an AFC-2 unit, if the receiver's IF deviates slightly from nominal center frequency, the AFC's action is to correct for the deviation and the audio sidebands

are frequency-positioned with minimum frequency distortion. Not shown on figure I-1-3, the SBS has a selector circuit to supply audio channels A and B with various modes of sideband transmission. Refer to the following paragraphs.

Figure I-4-3 is a functional block diagram of the SBS-1's signal circuits. The heavy solid line shows signal flow from the associated receiver's IF circuit. Assume a 455-kc center frequency. Mixer 6S4 is also fed by AFC-2's 705-kc reactance-tube oscillator. This means that the wanted output of the mixer is 705 minus 455 or 250 kc. The signal path is indicated by the heavy double-dot line. One path is back to the AFC-2 unit, in which frequency errors are corrected. Refer to the following paragraph (I-4-3). The second path is through a selector-switch-filter arrangement, in which frequency separation is made into two 250-kc channels, A and B, as follows:

Sideband	Bandwidth	Channel
upper	3.5 kc	A
lower	3.5 kc	B
upper	7.5 kc	A
lower	7.5 kc	B

The triple-dot heavy lines indicate these signal paths

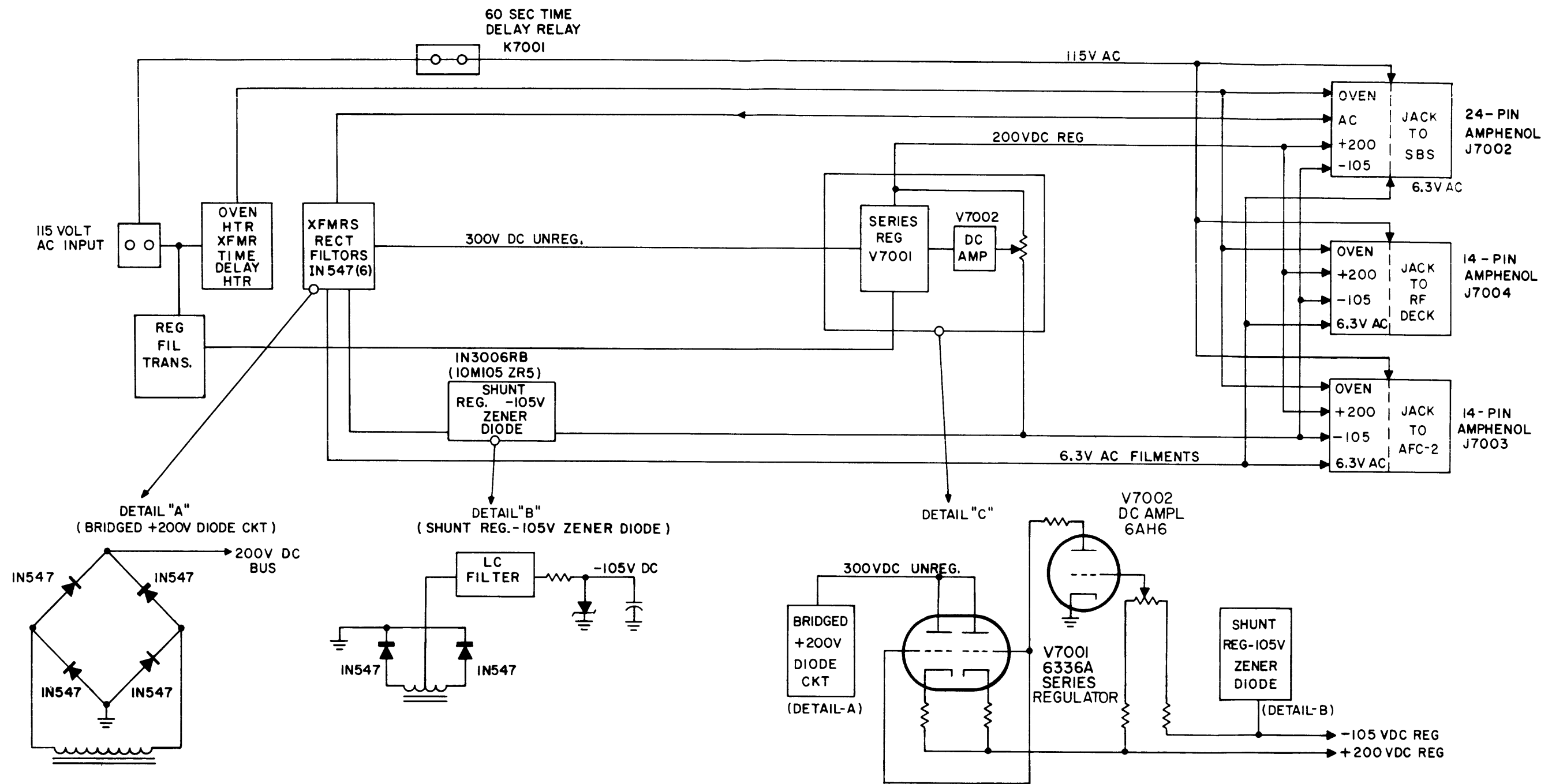

Figure 1-4-3. Block Diagram, Sideband Selector SBS-1
(Sheet 1 of 2)

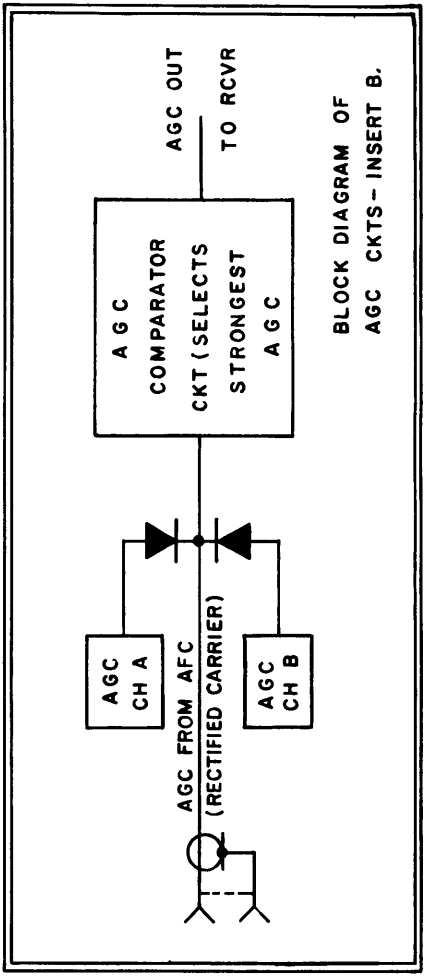
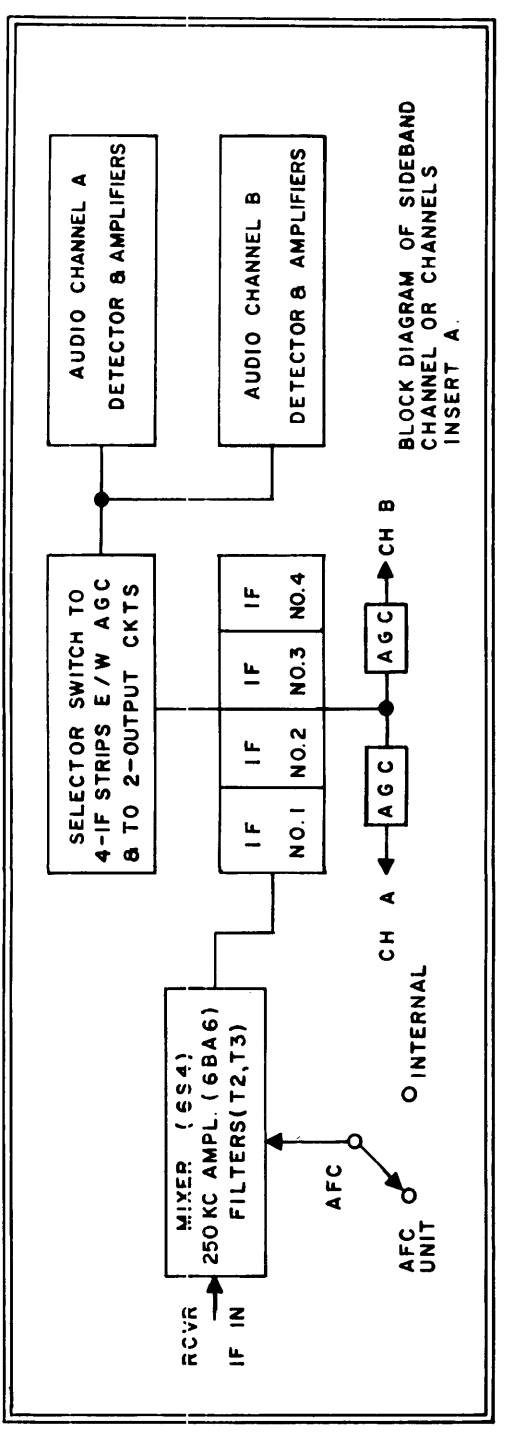
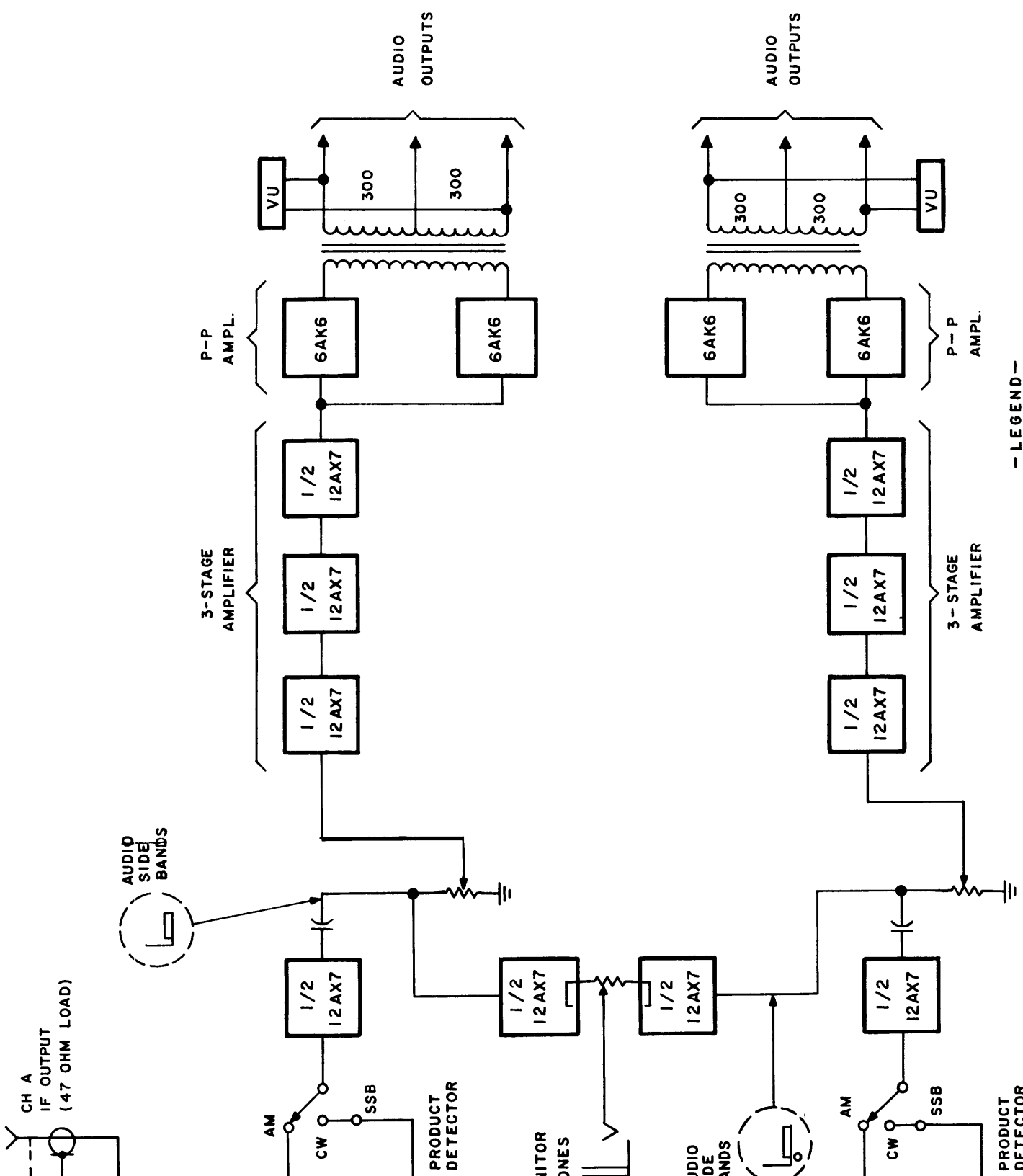
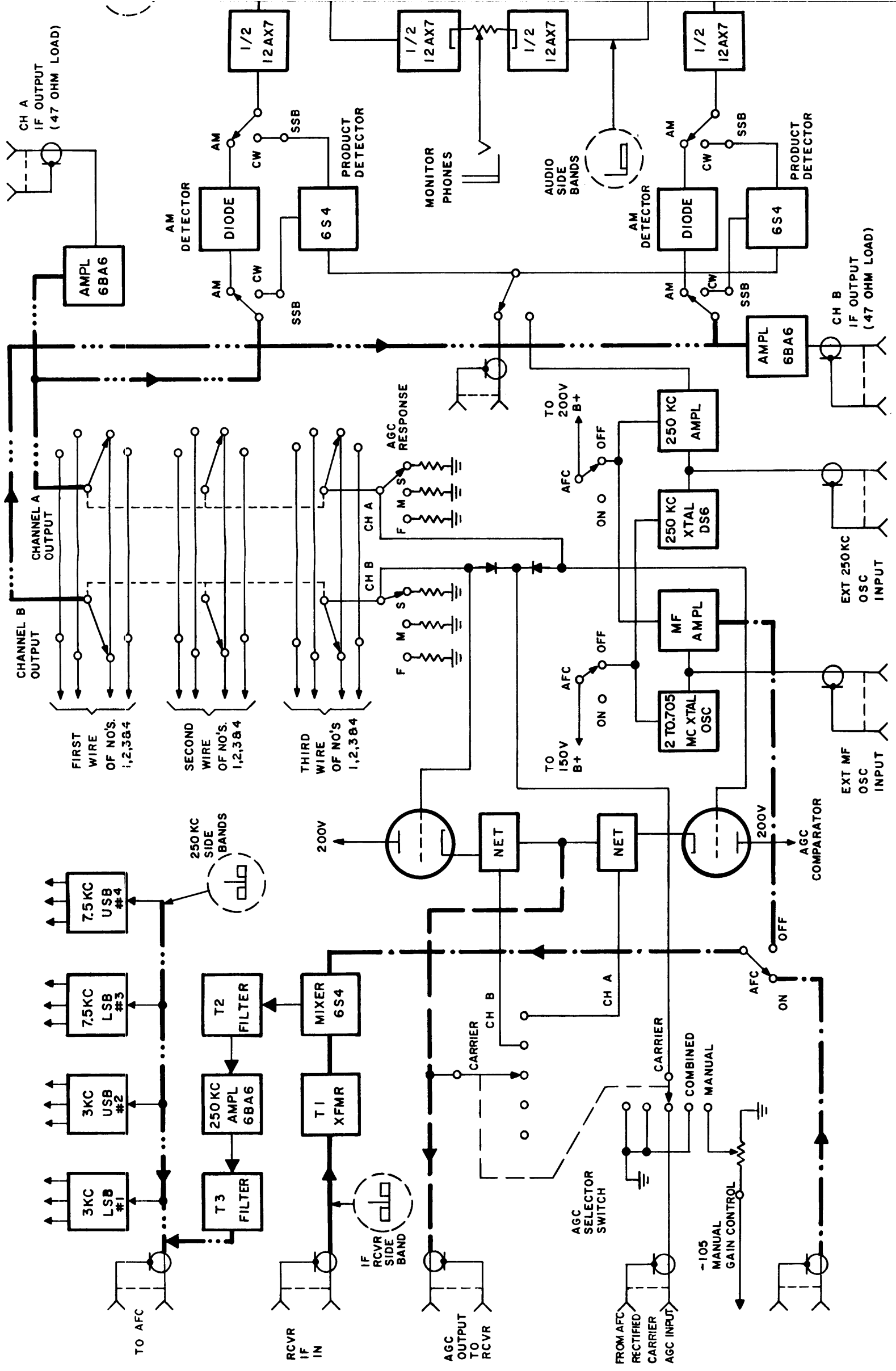

Figure I-4-3. Block Diagram, Sideband Selector SBS-1 (Sheet 2 of 2)



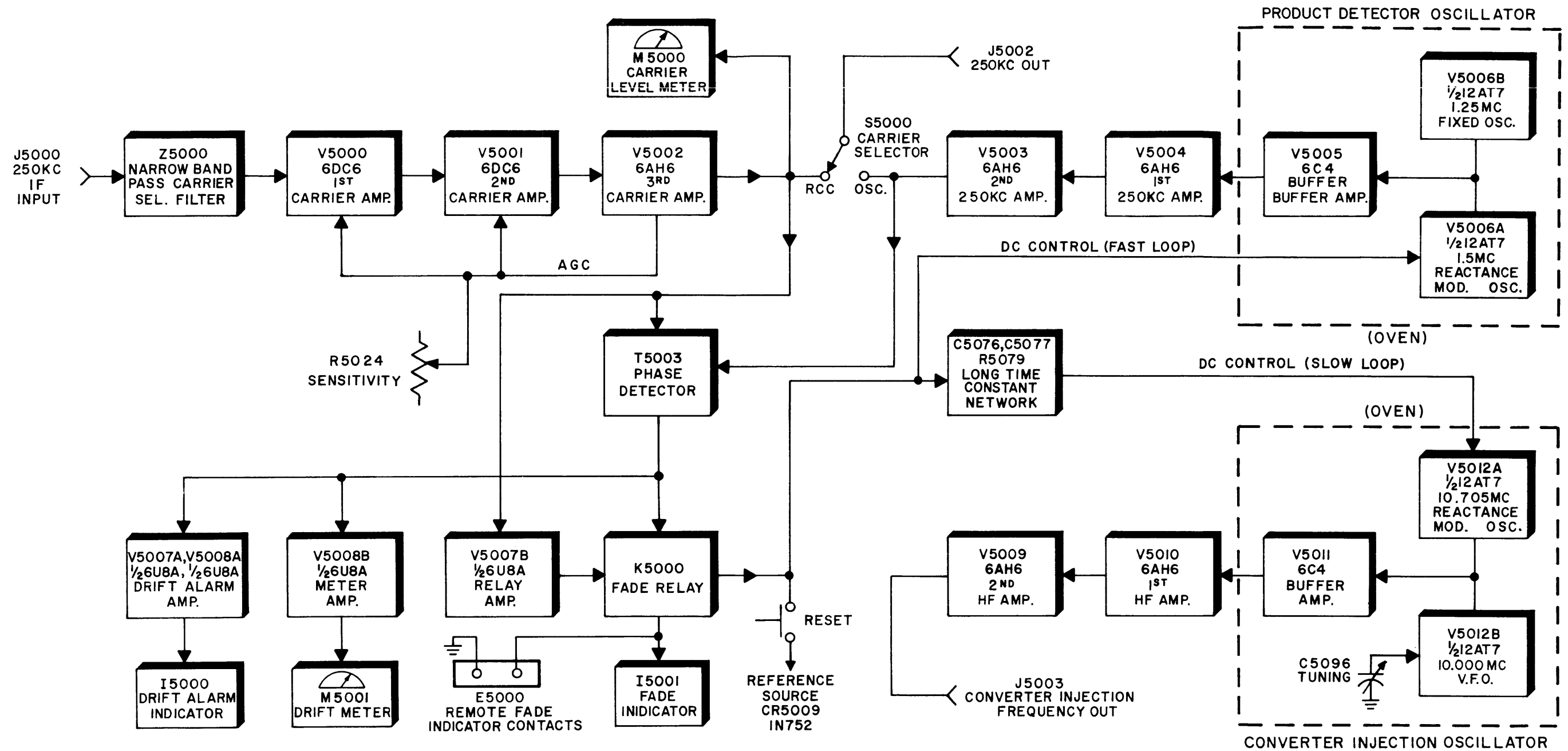

Figure I-4-4. Block Diagram, Automatic Frequency Control AFC-2

The final stage of the SBS-1 reduces the signals in the 250-kc channels A and B to audio. The audio outputs may be AM, CW, MCW, SSB, single-channel or Two-Channel (double or independent).

A second feature of the SBS-1 is its AGC supply. The circuitry is shown in simplified form in insert B on figure I-4-3. The diodes associated with the AGC output circuits receive AGC from three sources: (a) Channel A, 250 kc, (b) Channel B, 250 kc, and (c) rectified carrier from the AGC unit. A five-position AGC selector switch routes optimum AGC to the receiver as follows:

Channel	Usage
CH-A	Channel A only used.
CH-B	Channel B only used.
CARRIER	Strong carrier received.
CH-A-B	Channels A and B both used.
MANUAL	AFC disabled.

Figure I-4-3 also shows that the AGC response may be fast, medium, or slow. Selection is made by operation of a three-position AGC RESPONSE switch. The operator selects the switch position for best audio response.

For a complete analysis of SBS, see Part III and overall schematic diagram in Section 8 of Part III.

I-4-3. AUTOMATIC FREQUENCY CONTROL AFC-2. (See figure I-4-4.)

As shown in figure I-4-4, the AFC-2 contains two reactance-tube oscillators whose frequency outputs are controlled by a phase detector circuit. The phase detector's reference frequency is supplied by the SBS's mixer. Suppose the receiver's IF is $455 \text{ kc} + df_1$ and

the 705-kc reactance tube's frequency is $705 \text{ kc} + df_2$. The mixer's 250-kc outputs then become $705 \text{ kc} + df_2 - 455 \text{ kc} - df_1$ or $250 \text{ kc} + df_2 - df_1$. The 250-kc reactance tube's output also becomes $250 \text{ kc} + df_2 - df_1$. Consequently, both of the 250-kc input circuits of the product detector function at $250 \text{ kc} + df_2 - df_1$. Thus, the AFC's action is to correct for the receiver's deviation from center frequency. If $df_1 = df_2 = df$:

- a. receiver's IF is $455 \text{ kc} + df$.
- b. 750-kc reactance tube's output frequency is $705 \text{ kc} + df$.
- c. phase detector's input frequencies are 250 kc.
- d. product detector's input frequencies are 250 kc.

Referring to figure I-4-2, the heavy solid line shows 250-kc signal flow to the phase detector from the SBS's mixer. This is the phase detector's reference frequency. This circuit is equipped with AGC and relay amplifiers to indicate deep fades and excessive AFC drifts. The circuit is also equipped with a vtvm to visually indicate excessive AFC drifts.

In figure I-4-2, the heavy dot-dash line shows (a) signal flow to the phase detector from the 250-kc reactance-tube oscillator (phase detector's comparison 250-kc frequency) and (b) signal flow to the SBS's product detector. This circuit is also equipped with AGC.

In figure I-4-2, the heavy dashed line shows 705-kc signal flow to the SBS's mixer from the AFC's 705-kc reactance-tube oscillator. The frequency at which this circuit functions is under control of the phase detector by means of a long time constant or a delay circuit; the circuit is also equipped with AGC.

SECTION 5

TROUBLE-SHOOTING

Generalized phases of trouble-shooting are outlined below; detailed phases of trouble-shooting appear in Parts II and III as pertinent to the SBC's specific equipment units.

I-5-1. GENERAL.

Trouble-shooting is the art of locating and diagnosing equipment troubles and maladjustments; the information necessary to remedy the equipment troubles and maladjustments is contained in the various associated Sections 6 of the manual under the heading "Maintenance".

Trouble-shooting tools may, for convenience, be divided into the following six categories:

- a. Accurate schematic diagrams.
- b. Tables of voltage and resistance; waveform data.
- c. Location data (photographs with callouts of the major electronic equipment elements).
- d. Trouble-shooting techniques.
- e. Trouble-shooting charts based on operating procedures.
- f. Trouble-shooting procedures based on circuit sectionalization.

Trouble-shooting techniques (item d) are about the same for all types of electronic equipment and are covered briefly in the following paragraphs.

I-5-2. TROUBLE-SHOOTING TECHNIQUES.

a. GENERAL CONSIDERATIONS. - When a piece of equipment has been working satisfactorily and suddenly fails, the cause of failure may be apparent either because of circumstances occurring at the time of failure or because of symptoms analogous to past failures. In this case, it is unnecessary to follow a lengthy and orderly course of trouble-shooting in order to localize and isolate the faulty part.

A second short cut in trouble-shooting is to ascertain that all tubes and fuses are in proper working order and that the equipment receives proper supply

voltages. Many times this will eliminate further investigation.

A third short cut is to examine the equipment, section by section, for burned-out elements, charring, corrosion, arcing, excessive heat, dirt, dampness, etc. It is important to recognize that defective elements may have become defective due to their own weakness or to some contributing cause beyond their control.

Sometimes vibration will cause failure; for example, when joints are poorly soldered or when components normally isolated from each other are shaken together. Such failures are more difficult to locate.

b. TROUBLE-SHOOTING CHARTS BASED ON OPERATING PROCEDURES. - The general purpose of these charts is to narrow the area of trouble to one or more sections of the equipment in order to minimize the labor of locating the source of trouble. These charts present a prescribed order "to turn on" the equipment, indicate what to expect as each step is taken, and give some clues as to possible "trouble areas" when some expectation is not realized.

c. TABLES OF VOLTAGE AND RESISTANCE; WAVEFORM DATA. These tables give nominal values of voltage-to-frame and resistance-to-frame, generally at tube elements and sometimes at connectors and terminal-board elements. During this process, accurate diagrams and location data are essential. Schematic diagrams of all equipments will be found in the various Sections 8 of the manual.

A good oscilloscope is a first-class trouble-shooting tool. It may be connected to a number of critical points along a circuit to detect extraneous or abnormal voltages, distorted waveforms, and other symptoms of trouble.

d. TROUBLE-SHOOTING PROCEDURES BASED ON CIRCUIT SECTIONALIZATION. - Equipments usually consist of a number of subassemblies or sections. It is frequently helpful to treat these subassemblies or sections as independent entities. In so doing, however, they must be properly powered. Observations may then be made with vtvm's, cro's, or other test equipment, at selected points under given types and magnitudes of injection voltages. Again, the subassemblies or sections may be examined for rated performance according to specifications, for the presence of extraneous grounds, for opens, or for unusual voltages.

SECTION 6 MAINTENANCE

Generalized phases of maintenance are outlined below; detailed phases of maintenance appear in Parts II and III as pertinent to the SBC's specific equipment units.

I-6-1. OPERATOR'S MAINTENANCE.

Operator's maintenance consists in not only maintaining optimum equipment performance at all times but also in keeping a detailed record of the equipment performance as well as a log of events and happenings, including climatic conditions, pertinent to equipment operation. Such records are useful in spotting gradual equipment deterioration and when more general remedial measures are necessary.

I-6-2. PREVENTIVE MAINTENANCE.

Preventive maintenance is maintenance that detects and corrects trouble-producing factors before they become serious enough to affect equipment operation adversely. Some trouble-producing factors are dirt and grime, contact erosion, improper contact pressure, lack of proper lubrication, improper relay adjustment, dirty air filter, overheating, unstable power supplies, vacuum tubes with poor emission, loose parts (due to vibration), etc.

It may seem contradictory to state that good preventive maintenance means that one should not constantly poke around and tinker with an equipment that is performing excellently. Overzealous maintenance can readily cause more, rather than less, trouble. Good preventive maintenance requires constant vigilance and good judgment of what kinds of remedial measures to apply and when and how to apply them.

a. ONCE EACH SHIFT DURING AN "ON THE AIR" PERIOD. - Check the operator's performance record for irregularities and possible sources of future trouble. Make minor adjustments of tuning controls to verify proper tuning. Observe all electrical quantities

measurable with the built-in meter, and compare observations with established standards for irregularities. Observe indicator lights, and rectifier tubes for abnormal color and signs of internal flashing.

b. DAILY DURING AN "OFF THE AIR" PERIOD. - Visually and manually inspect parts for overheating and damage. Inspect sliding or moving coil contacts. Feel blower motor for overheating, and observe rotating parts for wear. Note deposits of dust and dirt. Inspect relay contacts. Check operation of all interlocks.

c. MONTHLY DURING "OFF THE AIR" PERIODS. - Recondition rotary and switch contacts as necessary. Use crocus cloth and trichlorethylene or ethylenedichloride for cleaning. Inspect the equipment and rid it of dust and dirt. Check the condition of the air filter; replace or clean dirty filters. Inspect the equipment for loose soldered connections or loose screws, especially in sections subject to appreciable vibration in service. Note the condition of gear trains; those showing signs of becoming dry should be lubricated with a drop or two of any high-quality, light machine lubricant. Check the condition of all tubes.

I-6-3. CORRECTIVE MAINTENANCE.

Corrective maintenance is an aftermath of troubleshooting as discussed in Section 5 or preventive maintenance as discussed in the preceding paragraph. With the exception of those cases when components suddenly fail for no apparent good reason or under extenuating circumstances, an intelligent program of preventive maintenance should produce minimum equipment outage.

After a defective part has been localized and isolated by the trouble-shooting techniques presented in various Sections 5 of the manual, replacement generally presents no major problem, particularly in the case of failure of non-complex electrical and mechanical components.