

TECHNICAL MANUAL
for

HIGH FREQUENCY
SYNTHESIZED TRANSMITTER
MODEL HFTA-1KJ2

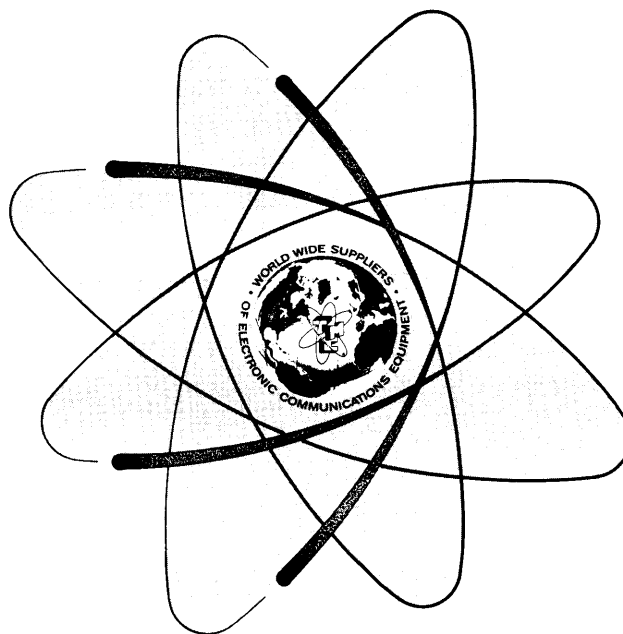

THE TECHNICAL MATERIEL CORPORATION
MAMARONECK, N.Y. OTTAWA, ONTARIO

COPYRIGHT 1971
THE TECHNICAL MATERIEL CORPORATION

Printed in U.S.A.

IN 1053J2

Issue Date: JULY 1971

NOTICE

THE CONTENTS AND INFORMATION CONTAINED
IN THIS INSTRUCTION MANUAL IS PROPRIETARY
TO THE TECHNICAL MATERIEL CORPORATION
TO BE USED AS A GUIDE TO THE OPERATION
AND MAINTENANCE OF THE EQUIPMENT FOR
WHICH THE MANUAL IS ISSUED AND MAY NOT
BE DUPLICATED EITHER IN WHOLE OR IN
PART BY ANY MEANS WHATSOEVER WITHOUT
THE WRITTEN CONSENT OF THE TECHNICAL
MATERIEL CORPORATION.

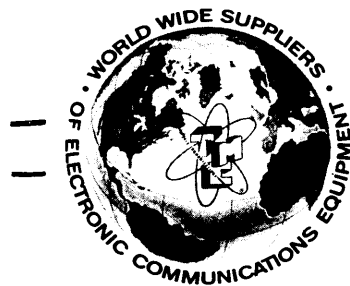

THE TECHNICAL MATERIEL CORPORATION

C O M M U N I C A T I O N S E N G I N E E R S

700 FENIMORE ROAD

MAMARONECK, N. Y.

Warranty

The Technical Materiel Corporation, hereinafter referred to as TMC, warrants the equipment (except electron tubes,*fuses, lamps, batteries and articles made of glass or other fragile or other expendable materials) purchased hereunder to be free from defect in materials and workmanship under normal use and service, when used for the purposes for which the same is designed, for a period of one year from the date of delivery F.O.B. factory. TMC further warrants that the equipment will perform in a manner equal to or better than published technical specifications as amended by any additions or corrections thereto accompanying the formal equipment offer.

TMC will replace or repair any such defective items, F.O.B. factory, which may fail within the stated warranty period, PROVIDED:

1. That any claim of defect under this warranty is made within sixty (60) days after discovery thereof and that inspection by TMC, if required, indicates the validity of such claim to TMC's satisfaction.
2. That the defect is not the result of damage incurred in shipment from or to the factory.
3. That the equipment has not been altered in any way either as to design or use whether by replacement parts not supplied or approved by TMC, or otherwise.
4. That any equipment or accessories furnished but not manufactured by TMC, or not of TMC design shall be subject only to such adjustments as TMC may obtain from the supplier thereof.

Electron tubes*furnished by TMC, but manufactured by others, bear only the warranty given by such other manufacturers. Electron tube warranty claims should be made directly to the manufacturer of such tubes.

TMC's obligation under this warranty is limited to the repair or replacement of defective parts with the exceptions noted above.

At TMC's option any defective part or equipment which fails within the warranty period shall be returned to TMC's factory for inspection, properly packed with shipping charges prepaid. No parts or equipment shall be returned to TMC, unless a return authorization is issued by TMC.

No warranties, express or implied, other than those specifically set forth herein shall be applicable to any equipment manufactured or furnished by TMC and the foregoing warranty shall constitute the Buyers sole right and remedy. In no event does TMC assume any liability for consequential damages, or for loss, damage or expense directly or indirectly arising from the use of TMC Products, or any inability to use them either separately or in combination with other equipment or materials or from any other cause.

*Electron tubes also include semi-conductor devices.

PROCEDURE FOR RETURN OF MATERIAL OR EQUIPMENT

Should it be necessary to return equipment or material for repair or replacement, whether within warranty or otherwise, a return authorization must be obtained from TMC prior to shipment. The request for return authorization should include the following information:

1. Model Number of Equipment.
2. Serial Number of Equipment.
3. TMC Part Number.
4. Nature of defect or cause of failure.
5. The contract or purchase order under which equipment was delivered.

PROCEDURE FOR ORDERING REPLACEMENT PARTS

When ordering replacement parts, the following information must be included in the order as applicable:

1. Quantity Required.
2. TMC Part Number.
3. Equipment in which used by TMC or Military Model Number.
4. Brief Description of the Item.
5. The *Crystal Frequency* if the order includes crystals.

PROCEDURE IN THE EVENT OF DAMAGE INCURRED IN SHIPMENT

TMC's Warranty specifically excludes damage incurred in shipment to or from the factory. In the event equipment is received in damaged condition, the carrier should be notified immediately. Claims for such damage should be filed with the carrier involved and not with TMC.

All correspondence pertaining to Warranty Claims, return, repair, or replacement and all material or equipment returned for repair or replacement, within Warranty or otherwise, should be addressed as follows:

THE TECHNICAL MATERIEL CORPORATION
Engineering Services Department
700 Fenimore Road
Mamaroneck, New York

TABLE OF CONTENTS

| Paragraph | | Page |
|--|--|------|
| <u>SECTION 1 - GENERAL INFORMATION</u> | | |
| 1-1 | Functional Description | 1-1 |
| 1-2 | Physical Description | 1-1 |
| 1-3 | Reference Data | 1-1 |
| <u>SECTION 2 - INSTALLATION</u> | | |
| 2-1 | Initial Unpacking and Inspection | 2-1 |
| 2-2 | Power Requirements | 2-1 |
| 2-3 | Installation | 2-1 |
| 2-4 | Pre-Operational Check | 2-5 |
| <u>SECTION 3 - OPERATOR'S SECTION</u> | | |
| 3-1 | General | 3-1 |
| 3-2 | Operating Control | 3-1 |
| 3-3 | Preliminary Control Settings | 3-1 |
| 3-4 | Operating Procedures | 3-2 |
| 3-5 | Emergency Operation | 3-10 |
| <u>SECTION 4 - PRINCIPLES OF OPERATION</u> | | |
| 4-1 | General | 4-1 |
| 4-2 | Overall Block Diagram Discussion | 4-1 |
| <u>SECTION 5 - MAINTENANCE AND TROUBLESHOOTING</u> | | |
| 5-1 | Introduction | 5-1 |
| 5-2 | Test Equipment Required | 5-1 |
| 5-3 | Operator's Maintenance Procedure | 5-1 |
| 5-4 | Preventive Maintenance | 5-2 |
| 5-5 | Troubleshooting | 5-2 |

LIST OF ILLUSTRATIONS

| Figure | | Page |
|--|--|------|
| <u>SECTION 1 - GENERAL INFORMATION</u> | | |
| 1-1 | HFTA-1KJ2 High Frequency Synthesized Transmitter | 1-0 |
| 1-2 | HFTA-1KJ2 Automated Transmitter Components . . . | 1-2 |
| <u>SECTION 2 - INSTALLATION</u> | | |
| 2-1 | HFTA-1KJ2 Typical Installation of Modular Units | 2-6 |
| 2-2 | HFTA-1KJ2 Exciter Interconnect Wiring Diagram . | 2-7 |
| 2-3 | HFTA-1KJ2 Interconnect Wiring Diagram | 2-8 |
| <u>SECTION 3 - OPERATOR'S SECTION</u> | | |
| 3-1 | Ratio of Average Power and PEP as a Function of Tones | 3-9 |
| <u>SECTION 4 - PRINCIPLES OF OPERATION</u> | | |
| 4-1 | Functional Block Diagram | 4-3 |

LIST OF TABLES

| Table | | Page |
|--|--|------|
| <u>SECTION 1 - GENERAL INFORMATION</u> | | |
| 1-1 | Major Components of HFTA-1KJ2 | 1-1 |
| 1-2 | Technical Specifications | 1-3 |
| 1-3 | Transmitter Power Tube Complement | 1-4 |
| <u>SECTION 3 - OPERATOR'S SECTION</u> | | |
| 3-1 | Preliminary Control Settings | 3-1 |
| 3-2 | Procedure for Manual Tuning on Carrier | 3-2 |
| 3-3 | Procedure for Automatic Tuning on Carrier . . . | 3-6 |

TRANSMIT/RECEIVE RELAY

MODEL AX740

The transmitter contains a Transmit/Receive Relay model AX740 that provides switching of a receivers input and transmitter output for operation with one antenna (simplex operation). Antenna switching is accomplished whenever the transmitter PTT circuit is activated (transmitter PTT relay energized). Thus the Transmit/Receive Relay is normally de-energized (receiver position) except when the transmitter PTT is activated. The relay (AX740) is mounted in the rear portion of the transmitter cabinet near the interface panel. A set of auxiliary contacts are provided on the relay for receiver muting if desired.

AX740 operates in conjunction with the transmitter push-to-talk circuitry within the transmitter. When the transmitter is equipped with AX740 minor wiring changes are made to the AP151 as indicated in Figure 1. Operation of AX740 is as follows:

A ground applied to TB1-6 causes Transmit/Receive Relay K1 to energize. The energized K1 relay contacts provide an antenna connection to the transmitter and a closure between TB1 terminals 1 & 5. The closure between terminals 1 & 5 provide a path to energize PTT relay K1 located in the AP151 power supply.

The energized PTT relay causes normal bias to be restored to the transmitter for normal operation and automatic tuning. The transmitter therefore cannot begin an auto tuning cycle until the Transmit/Receive Relay energizes.

Once the auto tune cycle is completed the Transmit/Receive Relay K1 is momentarily held energized via contact closure 15 & 16 on transmitter PTT relay located in AP151 power supply. After the transmitter PTT relay de-energizes and biases the transmitter off, Transmit/Receive Relay de-energizes and removes the antenna connection to the transmitter and provides an input to a receiver.

When troubleshooting the transmitter PTT circuit, close the PTT line (via exciter PTT switch or external PTT device connected to transmitter) and check for the following:

- TB1 terminal 6 ground
- terminal 3 24 vdc
- terminal 5 & 1 closure (continuity)
- terminal 2 ground
- terminal 4 ground (after READY lamp lights)

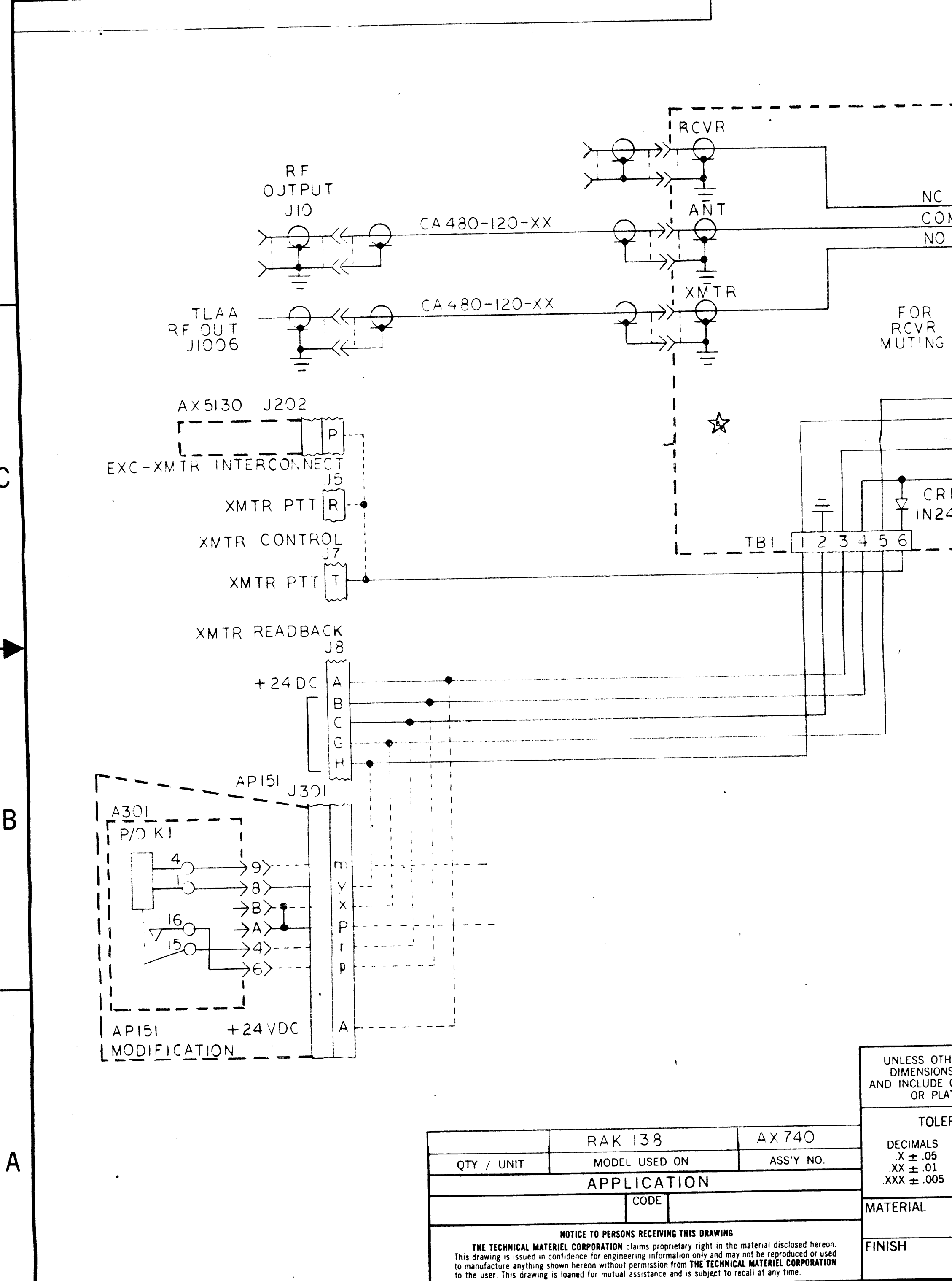

NC
COM
NO

FOR
RCVR
MUTING

CR1
IN248

TBI

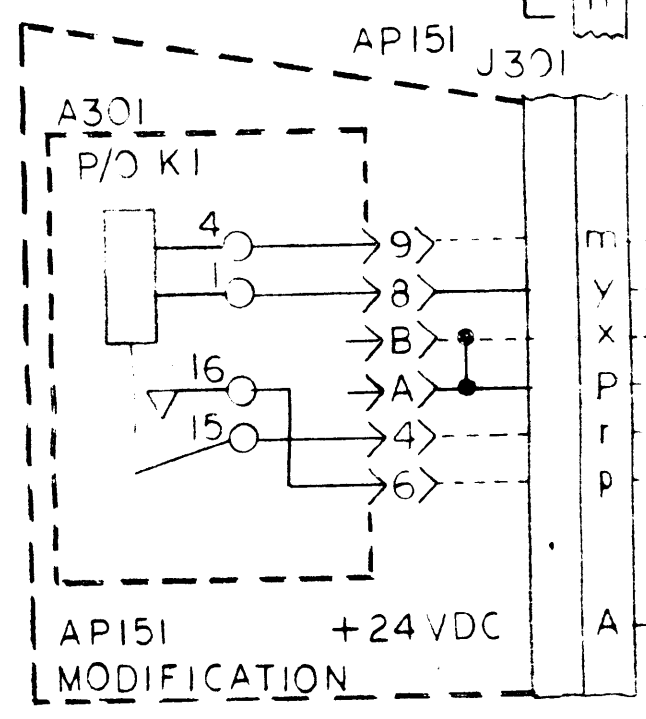

| | | |
|-------------|---------------|-----------|
| | RAK 138 | AX 740 |
| QTY / UNIT | MODEL USED ON | ASS'Y NO. |
| APPLICATION | | |
| | CODE | |

NOTICE TO PERSONS RECEIVING THIS DRAWING
 THE TECHNICAL MATERIEL CORPORATION claims proprietary right in the material disclosed hereon. This drawing is issued in confidence for engineering information only and may not be reproduced or used to manufacture anything shown hereon without permission from THE TECHNICAL MATERIEL CORPORATION to the user. This drawing is loaned for mutual assistance and is subject to recall at any time.

UNLESS OTHER
DIMENSIONS
AND INCLUDE CH
OR PLATE

TOLERA
DECIMALS
.X ± .05
.XX ± .01
.XXX ± .005

MATERIAL

FINISH

| REVISIONS | | | | | | |
|-----------|-----|---------------------------------|---------|----------|-------|-----------|
| ZONE | LTR | DESCRIPTION | DATE | E.M.N.NO | DRAFT | CHKD APPD |
| | X | ORIGINAL RELEASE FOR PRODUCTION | 9/24/72 | | W | |

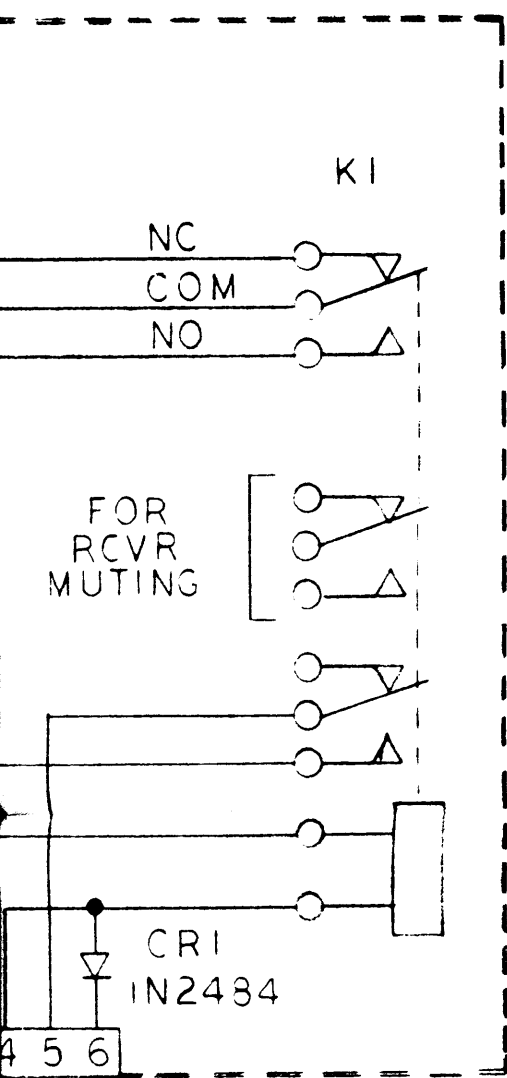

REFER TO § CHANGE THE FOLLOWING SCHEMATICS:

- CK1870 API51 PWR SPLY
- CK1883 AX5130 SERVO CONTROL (NO CHANGE)
- CK1904 RAK138-1A CABINET

INTERFACE J7 & J8 USED FOR CONNECTION POINT. DO NOT USE J8-B,C,G,H FOR EXTERNAL CONNECTIONS.

- DENOTES NEW CONNECTIONS.
- DENOTES EXISTING CONNECTIONS.

GROUND APPLIED TO J5-R OR J7-T STARTS SEQUENCE.

D

C

CK1935
 B

| QTY. REQ. | ITEM | PART NO. | DESCRIPTION | SYMBOL |
|---|-----------|-----------------------------------|----------------|---|
| LIST OF MATERIAL | | | | |
| UNLESS OTHERWISE SPECIFIED DIMENSIONS ARE IN INCHES AND INCLUDE CHEMICALLY APPLIED OR PLATED FINISHES | | FINAL APPROVAL <i>[Signature]</i> | DATE 20 MAR 72 | THE TECHNICAL MATERIEL CORP. MAMARONECK, NEW YORK DIAGRAM, SCHEMATIC XMIT/RCV RELAY AX 740 |
| TOLERANCES ON | | MECH. DES. | DATE | |
| DECIMALS | FRACTIONS | ELECT. DES. <i>[Signature]</i> | DATE 20 MAR 72 | |
| .X ± .05 | ± 1/64 | CHECKED | DATE | |
| .XX ± .01 | ANGLES | DRAWN <i>[Signature]</i> | DATE 20 MAR 72 | |
| .XXX ± .005 | ± 0°-30' | | | |
| MATERIAL | | | SIZE C | CODE IDENT.NO. 82679 |
| FINISH | | | | DWG NO. FIGURE 1 |
| | | | SCALE | SHEET OF |

A

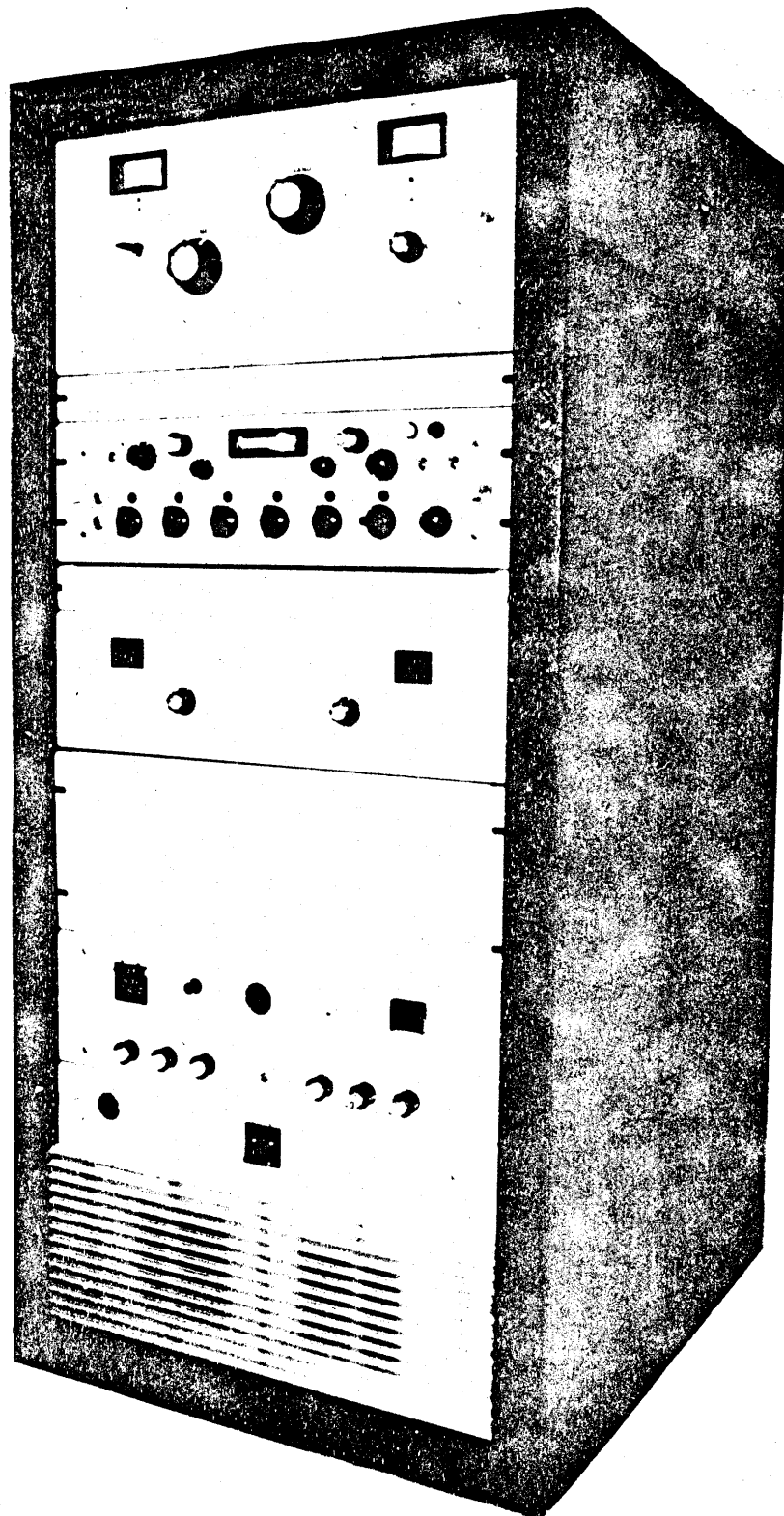

Figure 1-1. HFTA-1KJ2
High Frequency Synthesized Transmitter

SECTION 1

GENERAL INFORMATION

1-1. FUNCTIONAL DESCRIPTION

The HFTA-1KJ2 shown in figure 1-1, is an automated one kilowatt transmitter, designed and manufactured by The Technical Materiel Corporation, Mamaroneck, New York. The automated one kilowatt transmitter HFTA-1KJ2 hereinafter referred to as the transmitter, consists of a solid state, multi-mode, exciter MMX(A)-2, used in conjunction with a high frequency linear power amplifier HFLA-1K. The exciter is capable of providing CW (carrier wave), AM (amplitude modulation), SSB (single sideband) including AME (amplitude modulation equivalent), ISB (independent sideband), FSK (frequency shift keying) and FAX (facsimile) modes of operation. The linear power amplifier amplifies the exciter output to provide 1 kilowatt peak envelope power or average power throughout the frequency range of 2.0 MHz to 30 MHz.

Table 1-1 lists the major transmitter components.

TABLE 1-1. MAJOR COMPONENTS OF HFTA-1KJ2

| <u>NOMENCLATURE</u> | <u>COMMON NAME</u> |
|---------------------|------------------------|
| MMX(A)-2 | Multi-Mode Exciter |
| HFLA-1K | Linear Power Amplifier |

1-2. PHYSICAL DESCRIPTION

As shown in figures 1-1 and 1-2, the transmitter consists of a single equipment rack, which houses all of the transmitter components. The HFLA-1K portion of the transmitter consists of four individual units: (1) TLAA-1K, a three stage linear power amplifier, (2) AP-151, a low voltage and bias power supply, (3) AP-152, a high voltage power supply, and (4) AX-5130, a unit which contains all of the control and sensing circuitry for automatic tuning of the transmitter.

Primary power and external input connections to the transmitter are made at the power input jack (J2001) and interface panel located in the rear of the transmitter. RF power output is routed from a directional coupler located in the TLAA-1K. (In some configurations the directional coupler is located in the Harmonic Filter which is an optional item.) The antenna connection is made at the output connector (J10) located on the interface panel.

1-3. REFERENCE DATA

Table 1-2 lists the technical characteristics of the Automated Transmitter, HFTA-1KJ2. Table 1-3 lists the power tube complement of the transmitter; all power tubes are located in the TLAA-1K unit of the HFLA-1K Linear Power Amplifier.

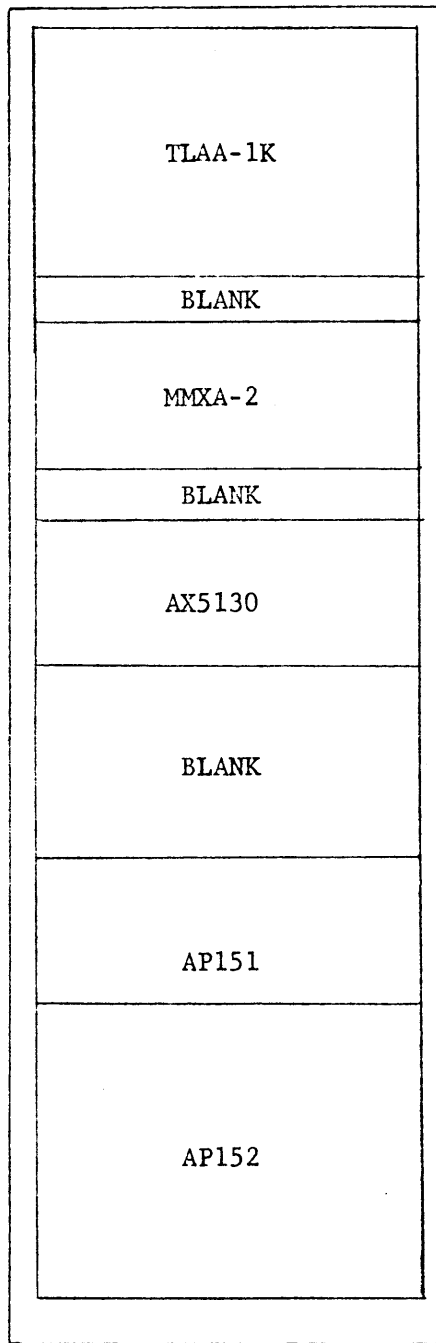

Figure 1-2. HFTA-1KJ2 Component Location

TABLE 1-2. TECHNICAL SPECIFICATIONS

| | |
|----------------------------------|---|
| Frequency Range: | 2.0 to 30 MHz standard. |
| Stability and Frequency Control: | Within 1 part in 10^8 ; higher stability may be achieved with the use of an external standard. |
| Operating Modes: | CW, AM, SSB, ISB, AME, FAX and FSK. |
| Sideband Response: | ± 1.5 db from 250 to 6080 Hz. |
| Power Output: | 1000 watts average or PEP; continuous key down service. |
| Output Impedance: | 50 ohms, unbalanced. |
| VSWR: | Maximum of 2:1 without degrading performance. |
| ALDC: | Automatic Load and Drive Control to improve linearity, limit distortion, and maintain a relatively constant output level during high modulation peaks and load changes. Front panel control allows adjustment of the level at which the ALDC takes effect. |
| Tuning: | Automatic or manual; automatic has manual override. |
| Special Features: | Overload protection and alarm. Safety interlocks at all high voltage points. |
| Carrier Suppression: | Carrier suppression is selectable in four positions and referenced to PEP. (1) 0: full carrier (2) -6: provides 3 to 6 db of carrier suppression (3) -16: provides 16 ± 2 db of carrier suppression (4) full: provides at least -40 db of carrier suppression |
| Spurious Response: | At least 73 db down from PEP output for CW and FSK; at least 70 db down from PEP for all other operating modes. |
| Intermodulation: | Distortion products are at least 35 db below either tone of a standard two-tone test at full rated PEP. |
| Hum and Noise: | 50 db down; special "white noise" protection. |

TABLE 1-2. TECHNICAL SPECIFICATIONS (continued)

| | |
|------------------------------|---|
| Power Supply Ripple: | Power supply ripple 55 db down from full PEP output. |
| Cooling: | Filtered forced air cooling; semi-pressurized cabinet. |
| Environmental: | Designed to operate in any ambient temperature between the limits of 0 and 50°C for any value of humidity to 90%. |
| Primary Power: | 230/115 vac single phase, 50/60 Hz. |
| Power Requirements: | Approximately 3.75 kilowatts. |
| Size: | 23 W x 27-1/2 D x 49-3/8 H. |
| Installed Weight: | Approximately 550 pounds. |
| Components and Construction: | Manufactured in accordance with JAN/MIL wherever practicable. |

TABLE 1-3. TRANSMITTER POWER TUBE COMPLEMENT

| <u>Reference Designation</u> | <u>Part Number or Type</u> | <u>Function</u> |
|------------------------------|----------------------------|------------------|
| V1201 | 8233 | 1st RF Amplifier |
| V1202 | 4CX350A | 2nd RF Amplifier |
| V1301 | 8576 | Power Amplifier |

SECTION 2

INSTALLATION

2-1. INITIAL UNPACKING AND INSPECTION

The HFTA-1KJ2 was assembled, calibrated and tested at the factory before shipment. Inspect all packages for possible damage during transit. With respect to damage to the equipment for which the carrier is liable, The Technical Materiel Corporation will assist in describing methods of repair and furnishing of replacement parts. Carefully unpack each crate as indicated by the packing list provided with the transmitter shipment. Inspect all packing materials for parts that may have been shipped as LOOSE ITEMS (cabinet hardware, connectors, technical manuals, etc.).

2-2. POWER REQUIREMENTS

The HFTA-1KJ2 requires a single phase source of 115 or 230 vac, 50/60 Hz at approximately 3.75 kilowatts.

2-3. INSTALLATION

a. General

A minimum number of assemblies, subassemblies, components and hardware have been disassembled from the equipment and separately packaged, thus reducing the possibility of equipment damage in transit. The method of disassembly and separate packaging also permits realistic equipment handling.

Cables, wires, and other miscellaneous items that are disconnected during equipment disassembly are tagged and taped to the equipment. The information on a given tag indicates the designated terminal on a component to which the tagged item must be connected. Make sure all cables and wires have been connected as designated on tags and that all packing material, tags and tape have been removed before sealing-up the cabinet or section of the cabinet with a front panel drawer.

b. Component Installation

The component location for typical installation of the HFTA-1KJ2 is shown in figure 2-1. The following units in the transmitter are slide mounted: all components of the HFLA-1K (TLAA-1K, AX-5130, AP-151 and AP-152), and the MMX(A)-2. The modular units of the HFLA-1K should be installed into the equipment rack by referring to the detailed installation procedural steps in the technical manual for the HFLA-1K. The MMX(A)-2 should be installed in the equipment rack in the same manner as the HFLA-1K modular units; the front panel of the MMX(A)-2 should be fastened to the rack with four screws and four washers.

WARNING

BEFORE MAKING EXTERNAL CONNECTIONS TO THE TRANSMITTER, INSURE THAT THE EXTERNAL PRIMARY POWER IS OFF AND TAGGED.

c. Electrical Interconnections

Once the modular units (AP151, AP152, AX5130, MMX(A)-2 and TLAA-1K) have been mounted into the transmitter equipment cabinet, refer to figure 2-2 exciter interconnect diagram in conjunction with figure 2-3 HFTA-1KJ wiring diagram and connect all plugs to their respective jacks. All interconnecting cables are marked with their "J" numbers and mating "P" numbers at the plug for ease of installation.

d. Interface Panel Connections

External input connections are made at the Interface panel located in the rear of the transmitter below the AX5130 Servo Control drawer. Audio intelligence, CW, FSK and FAX input connections are made at Interface jack J7. Mating plugs for J6 (Exciter Control), J7 (XMTR control) and J8 (XMTR readback) are supplied as loose items. Refer to figure 2-3 HFTA-1KJ2 interconnect diagram and make the external connections to mating plugs prior to connecting plugs to J6, J7 and J8.

NOTE

The HFTA-1KJ2 leaves the factory wired for local operation. Mating plugs that connect to Interface Panel jacks J6, J7 and J8 are supplied as loose items and are NOT PREWIRED with connections between pins on each plug for transmitter operation. These mating plugs supplied as loose items must be wired in accordance with figure 2-3 and then connected to jacks J6, J7 and J8 on the Interface panel.

e. Interface Panel Connections to Enable Transmitter Operation

Remove mating plugs supplied as loose items for Interface Jacks J6, J7 and J8 (MS3106B24-28S, MS3106B24-28P and MS3106B24-21P respectively) and provide connections as follows:

(1) On the mating plug for J7 XMTR control (MS3106B24-28P)

Provide connection between pins "R" and "S" (H.V. ON/OFF)

Provide connection between pins "E" and "G" (Overload reset)

Provide connection between pins "B" and "C" (External Interlocks)

NOTE

The terminals for J7 not listed in the foregoing are for interface connections between the transmitter and indicator equipment (overload indicator, output meter control, etc.) refer to figure 2-3 for these connections.

Check all connections made and secure mating plug on Interface Panel jack J7.

(2) On the mating plug for J6 Exciter Control (MS3106B24-28S)

Provide shielded lines for the following:

| | |
|------------------|--|
| USB (600 ohm) | Pins "A", "B", "C" and "D" (C is Center tap, D is ground) |
| LSB (600 ohm) | Pins "E", "F", "G" and "H" (F is center tap, H is ground) |
| FSK | Pin "K" (-) Pin "L" (+) |
| FAX | Pin "N" |
| FSK Contact Key | Pin "P", "Q" (Q is ground) |
| CW Key | Pin "R", "S" (S is ground) |
| PTT (unshielded) | Pin "T", "U" (U is ground) |

(3) On the mating plug for J8, XMTR Readback (MS3106B24-21P)

Provide connections for the following readback status:

| | | |
|--------------------|--|---|
| +24 vdc | Pin "A" | |
| Receiver Mute | Pin "B" NO) Pin "C" COM) Pin "D" NC) | Receiver mute terminals are for XMTR off condition |
| Overload Indicator | Pin "E" NC) Pin "F" NO) Pin "G" NC) Pin "H" NO) | Overload Indicator terminals are for overload condition |
| Tuning Indicator | Pin "J" | |
| Fault Indicator | Pin "K" NC) Pin "L" NO) Pin "M" COM) | Fault indication terminals are for fault condition |
| Ready Indicator | Pin "N" | |

| | |
|-----------------------|----------------------------|
| H.V. OFF Indicator | Pin "P" |
| H.V. ON Indicator | Pin "R" |
| Not Ready Indicator | Pin "S" |
| FWD Power (shielded) | Pin "a", "b" (b is ground) |
| REFL Power (shielded) | Pin "c", "d" (d is ground) |

Check all connections and secure mating plug to Interface Panel jack J8.

(4) RF Output connection

Connect 50 ohm transmission line to Interface Panel jack J10. Transmission line should be terminated into 50 ohm dummy load or antenna.

This completes the external connections to the Interface Panel. Check that all connections are secure and correctly made, if necessary refer to figures 2-2 and 2-3.

f. Primary Power Connections

The transmitter leaves the factory wired as per customer requirements for 115 vac or 230 vac. Transmitter power requirements are as follows:

(1) 115 vac/or 230 vac (on request).

(2) Single phase AC at approximately 3.75 kw, 50/60 Hz. Connect Power plug to Power Input jack J2001 located on the bottom portion of the equipment cabinet.

NOTE

The equipment cabinet is equipped with two (2) safety interlock switches that must be closed before operating the transmitter. One interlock switch is located on rear wall of equipment cabinet and is closed when rear door is mounted on cabinet. A second interlock switch located on the front cabinet wall is closed when AP152 (bottom unit) is mounted into the equipment cabinet and fasten with panel locks.

g. Harmonic Filter Plug Connection (optional)

In configurations of the HFTA-1K that do not include the Harmonic filter, the plug that normally connects to the filter must be connected to terminating jack J401 to complete the interlock circuit. This jack is located in the right cabinet wall (as viewed from the rear of transmitter). Connect plug P2012 to J401 located on cabinet wall.

After all external connections are completed, insure that protective top and bottom covers are affixed on each modular unit and the

modular units are secured in the cabinet with panel locks or mounting hardware.

Mount rear door on cabinet and secure with mounting hardware provided.

2-4. PRE-OPERATIONAL CHECK

Although the transmitter has been aligned and thoroughly checked against the manufacturer's specifications prior to shipment, it is necessary to ensure correct installation and proper operation by referring to pre-operational checks in the applicable technical manuals for the modular units. High voltage transformer check of the HFLA-1K, and initial check-out of the MMX(A)-2 should be performed.

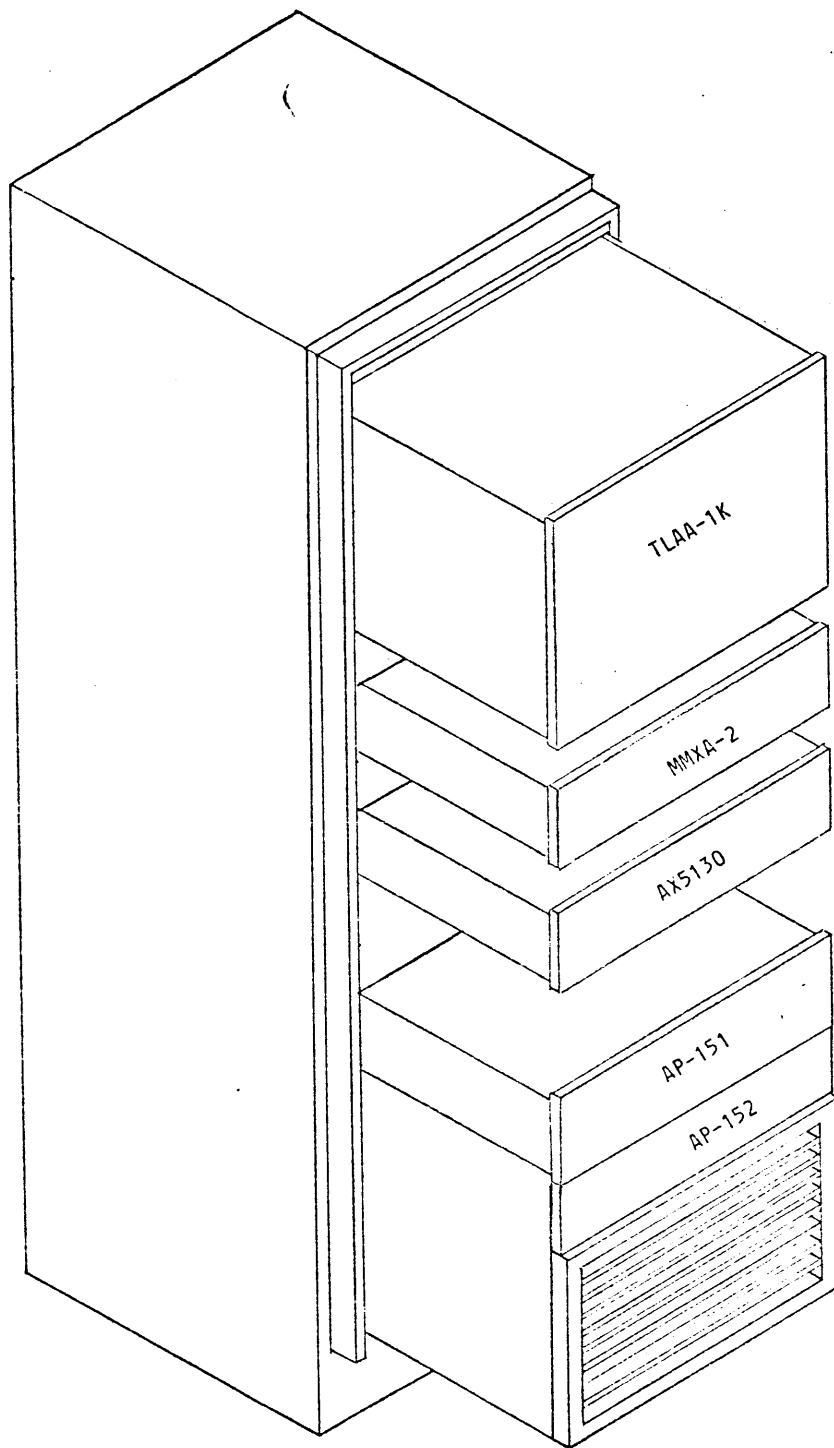

Figure 2-1.
HFTA-1KJ2 Typical Installation of Modular Units

EXCITER MMXA-2A

D

C

B

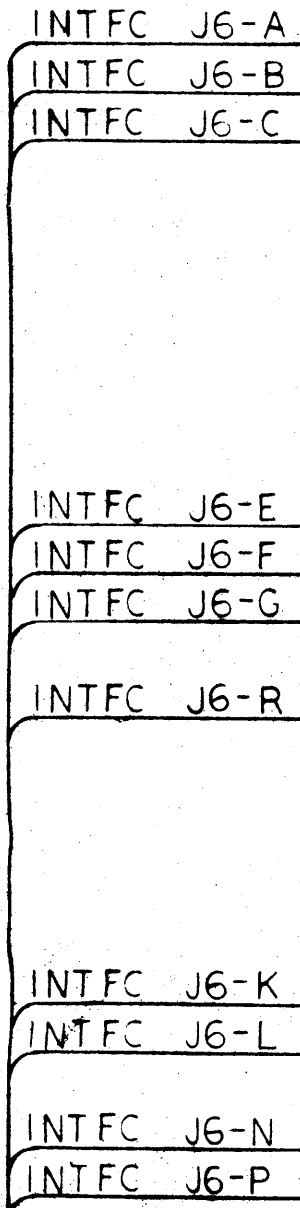
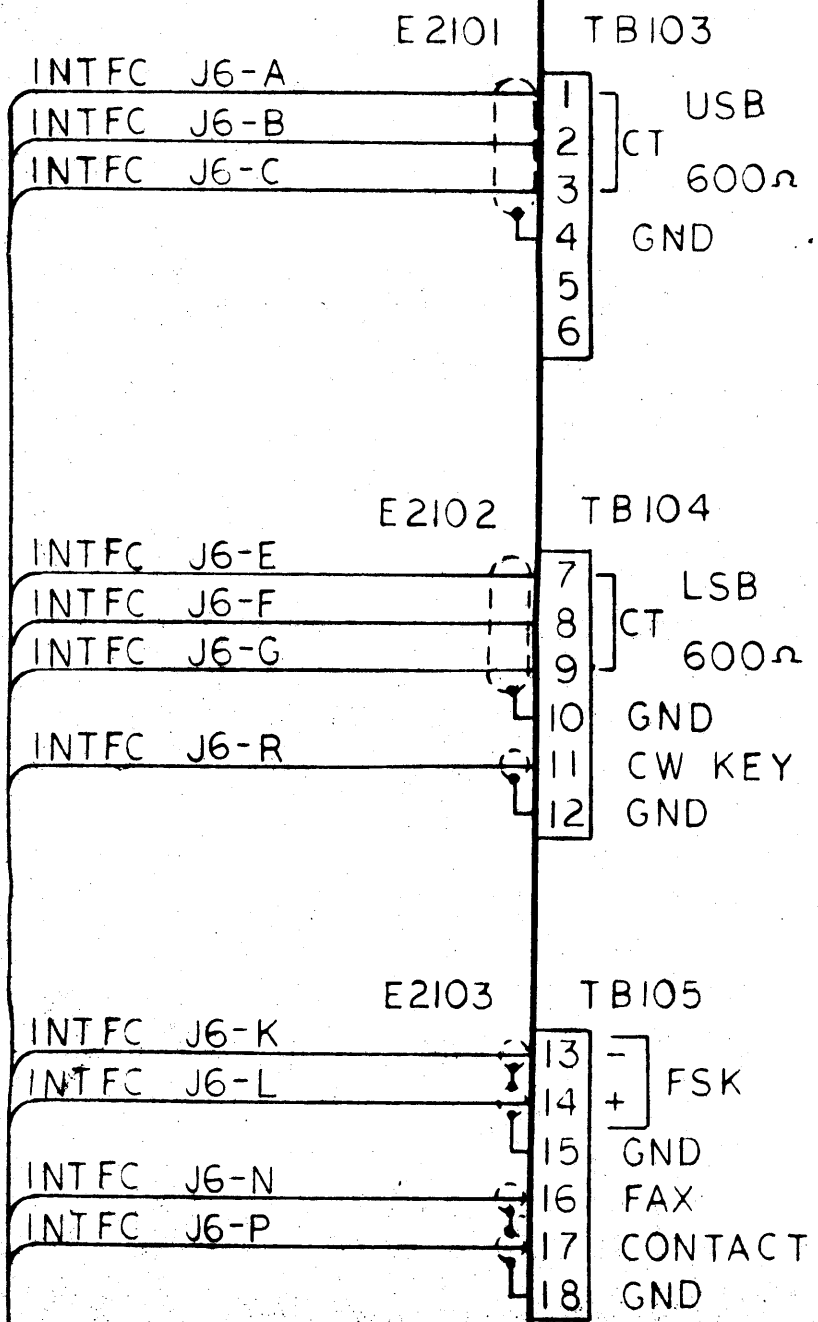
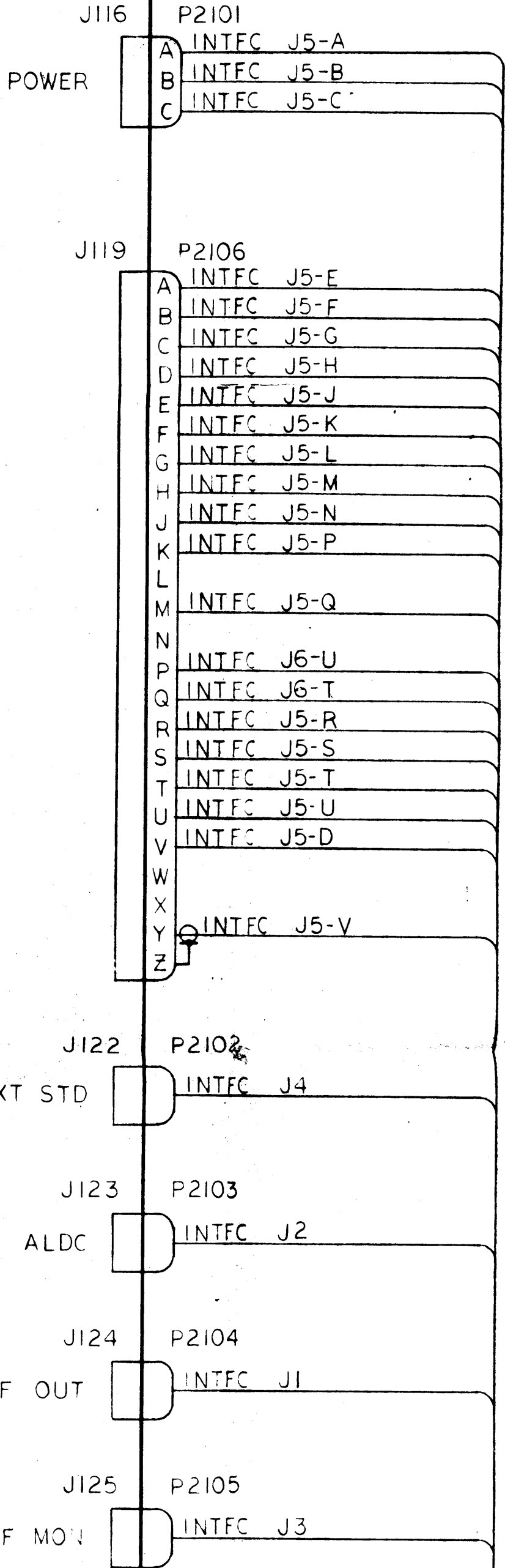



P/O INTERFACE

P/O INTERFACE

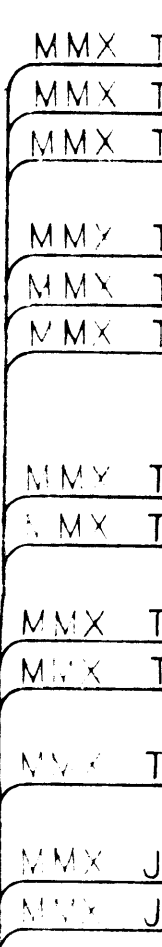
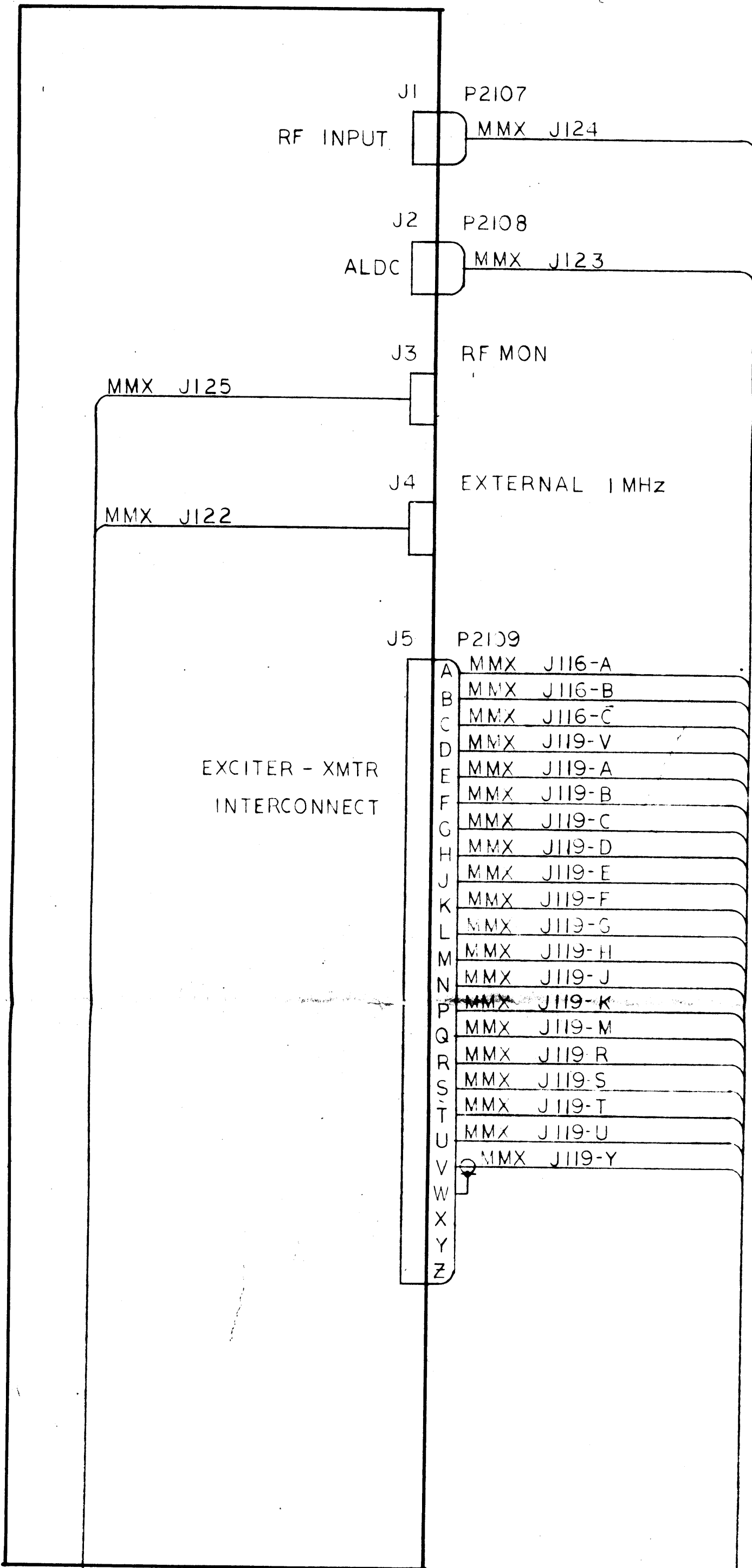

P/O INTERFACE

| | | | | REVISIONS | |
|----------|-------|------|------|-----------|-------------------------|
| E.M.N.NO | DRAFT | CHKD | ZONE | LTR | DESCRIPTION |
| | 0 | | | 0 | ORIGINAL FOR PRODUCTION |

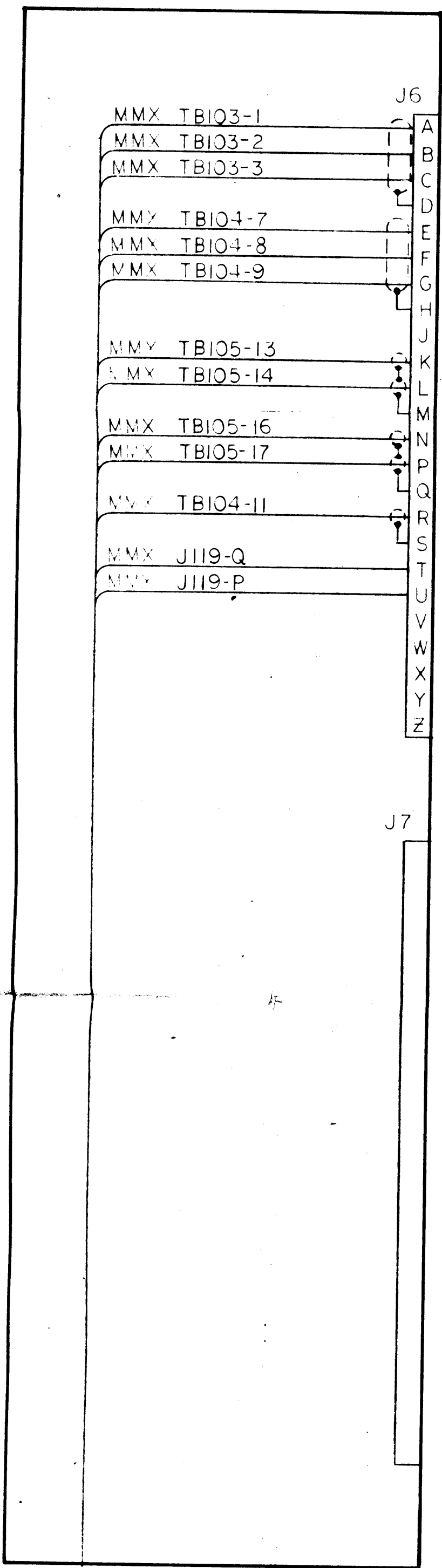

EXCITER CONTROL

CT USB
600 Ω

CT LSB
600 Ω

FSK

FAX
FSK CONTACT KEY

CW KEY

G PTT

LAST SYMBOLS
E 2103
P 2109

FOR INTERFACE CONNECTIONS
SEE CK1904

| | | | | | REVISIONS | | |
|----------|-------|------|------|-----|--------------------------------|---------|----------|
| E.M.N.NO | DRAFT | CHKD | ZONE | LTR | DESCRIPTION | DATE | APPROVED |
| | 0 | | | 0 | ORIGINAL DESIGN FOR PRODUCTION | 11/1/77 | |

6 EXCITER CONTROL

A
B
C
D
E
F
G
H
J
K
L
M
N
P
Q
R
S
T
U
V
W
X
Y
Z

CT USB 600Ω

CT LSB 600Ω

-
 + FSK

FAX
FSK CONTACT KEY

CW KEY

G PTT

LAST SYMBOLS
E 2103
P 2109

FOR INTERFACE CONNECTIONS
SEE CK1904

D

C



CK1905

EXT STD

INTFC J4

J123

P2103

ALDC

INTFC J2

J124

P2104

RF OUT

INTFC J1

J125

P2105

RF MOV

INTFC J3

CA1652

B

A

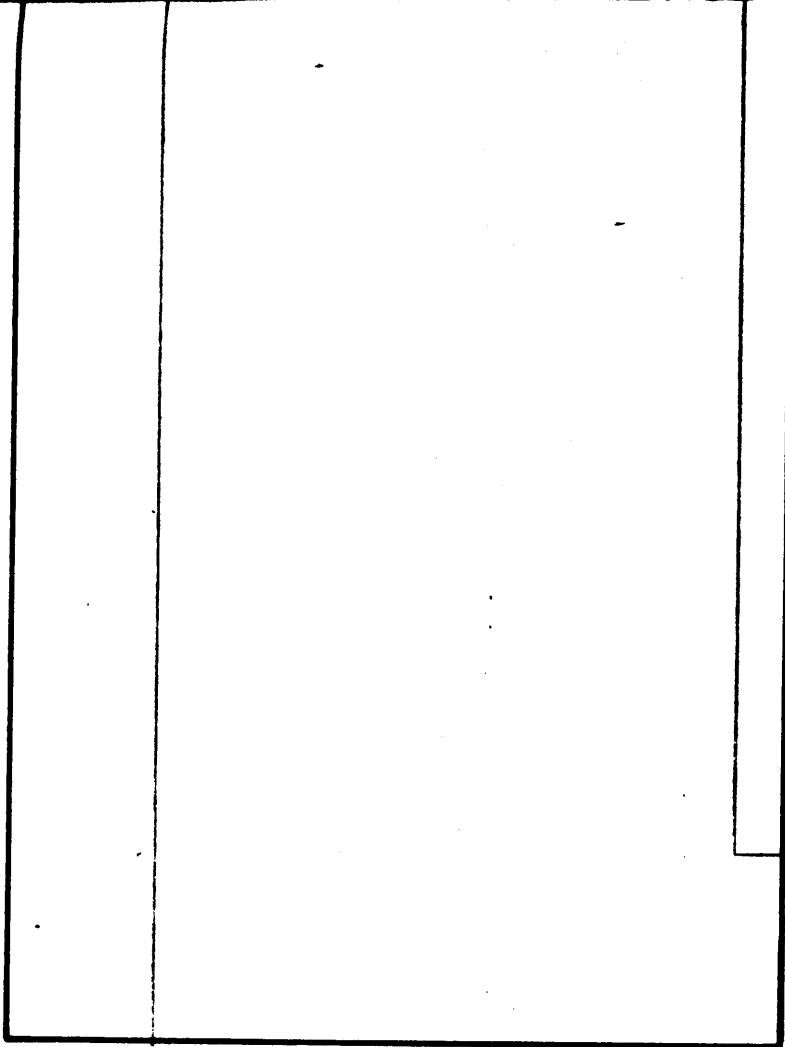

| QTY. REQ. | ITEM | PART NO. | DESCRIPTION |
|--|------|-----------------------------------|---|
| LIST OF MATERIAL | | | |
| UNLESS OTHERWISE SPECIFIED DIMENSIONS ARE IN INCHES AND INCLUDE CHEMICALLY APPLIED OR PLATED FINISHES | | FINAL APPROVAL <i>[Signature]</i> | DATE 28 Oct 71 |
| TOLERANCES ON DECIMALS FRACTIONS .X ± .05 ± 1/64 .XX ± .01 ANGLES .XXX ± .005 ± 0° -30' | | MECH. DES. | DATE |
| | | ELECT. DES. <i>[Signature]</i> | DATE 28 Oct 71 |
| | | CHECKED | DATE |
| | | DRAWN <i>[Signature]</i> | DATE 28 Sep 71 |
| MATERIAL | | | THE TECHNICAL HFTA-1KJ2 EXCITE Figure |
| FINISH | | | |

| | |
|--|-----------|
| HFTA-1KJ2 | |
| MODEL USED ON | ASS'Y NO. |
| APPLICATION | |
| CODE | |
| NOTICE TO PERSONS RECEIVING THIS DRAWING THE TECHNICAL MATERIEL CORPORATION claims proprietary right in the material disclosed hereon. Confidence for engineering information only and may not be reproduced or used hereon without permission from THE TECHNICAL MATERIEL CORPORATION loaned for mutual assistance and is subject to recall at any time. | |

4

3

2

B
CK1905
S

| QTY. REQ. | ITEM | PART NO. | DESCRIPTION | SYMBOL |
|--|------|--------------------------------------|--------------------|--|
| LIST OF MATERIAL | | | | |
| UNLESS OTHERWISE SPECIFIED DIMENSIONS ARE IN INCHES INCLUDE CHEMICALLY APPLIED OR PLATED FINISHES | | FINAL APPROVAL <i>[Signature]</i> | DATE 28 9-71 | THE TECHNICAL MATERIEL CORP. Figure 2-2 HFTA-1KJ2 EXCITER INTERCONNECT WIRING Page 2-7 |
| | | MECH. DES. | DATE | |
| TOLERANCES ON DECIMALS .05 .01 .005 | | ELECT. DES. <i>[Signature]</i> | DATE 28 9-71 | |
| FRACTIONS ± 1/64 ANGLES ± 0° -30' | | CHECKED | DATE | |
| DIMENSIONS ± .005 | | DRAWN <i>[Signature]</i> | DATE 28 5-71 | |
| | | | SIZE C | |
| | | | SCALE SC | |

A

2

1

LIN AMP
TLAA-1K

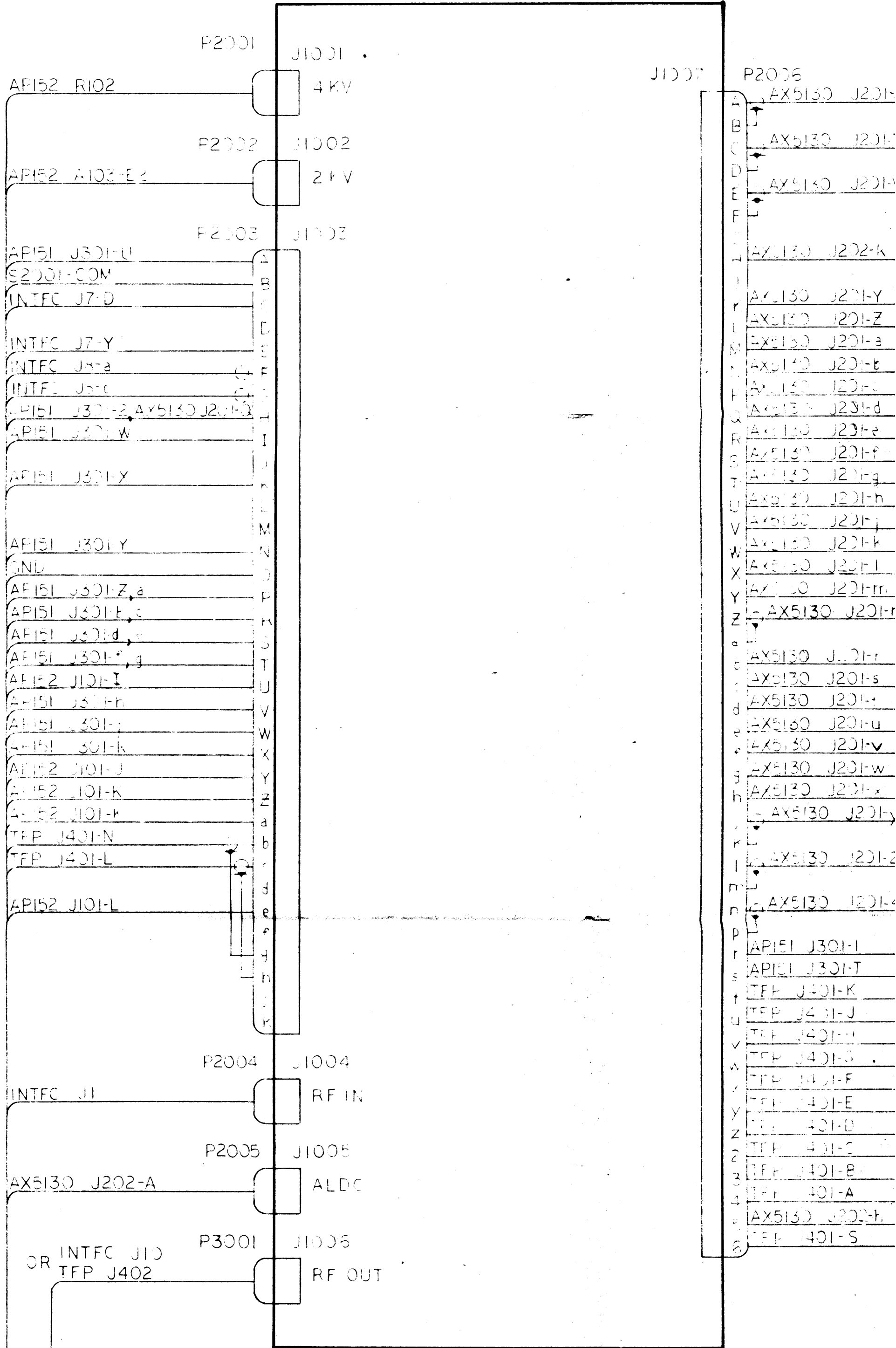

1007

P2006

| | |
|---|---------------|
| A | AX5130 J201-R |
| B | |
| C | AX5130 J201-T |
| D | |
| E | AX5130 J201-V |
| F | |
| G | |
| H | AX5130 J202-K |
| I | |
| J | |
| K | AX5130 J201-Y |
| L | AX5130 J201-Z |
| M | AX5130 J201-a |
| N | AX5130 J201-b |
| O | AX5130 J201-c |
| P | AX5130 J201-d |
| Q | AX5130 J201-e |
| R | AX5130 J201-f |
| S | AX5130 J201-g |
| T | AX5130 J201-h |
| U | AX5130 J201-i |
| V | AX5130 J201-j |
| W | AX5130 J201-k |
| X | AX5130 J201-l |
| Y | AX5130 J201-m |
| Z | AX5130 J201-n |
| 1 | |
| 2 | AX5130 J201-r |
| 3 | AX5130 J201-s |
| 4 | AX5130 J201-t |
| 5 | AX5130 J201-u |
| 6 | AX5130 J201-v |
| 7 | AX5130 J201-w |
| 8 | AX5130 J201-x |
| 9 | AX5130 J201-y |
| 0 | |
| 1 | AX5130 J201-2 |
| 2 | |
| 3 | AX5130 J201-4 |
| 4 | |
| 5 | API51 J301-I |
| 6 | API51 J301-T |
| 7 | TFP J401-K |
| 8 | TFP J401-J |
| 9 | TFP J401-H |
| 0 | TFP J401-G |
| 1 | TFP J401-F |
| 2 | TFP J401-E |
| 3 | TFP J401-D |
| 4 | TFP J401-C |
| 5 | TFP J401-B |
| 6 | TFP J401-A |
| 7 | AX5130 J202-F |
| 8 | |
| 9 | TFP J401-S |

| | |
|--------------|---|
| APIE1 J301-U | A |
| APIE1 J301-C | F |
| APIE1 J301-H | C |
| APIE1 J301-J | D |
| APIE1 J301-K | E |
| APIE1 J301-L | F |
| APIE1 J301-M | G |
| APIE1 J301-N | H |
| APIE1 J301-P | J |
| APIE1 J301-Q | K |
| APIE1 J301-R | L |
| APIE1 J301-S | M |
| APIE1 J301-T | N |
| APIE2 J101-F | P |
| TLA J1007-H | Q |
| TLA J1007-A | R |
| TLA J1007-C | S |
| TLA J1007-E | T |
| TLA J1007-K | V |
| TLA J1007-L | W |
| TLA J1007-M | X |
| TLA J1007-N | Y |
| TLA J1007-P | Z |
| TLA J1007-Q | a |
| TLA J1007-R | b |
| TLA J1007-S | c |
| TLA J1007-T | d |
| TLA J1007-U | e |
| TLA J1007-V | f |
| TLA J1007-W | g |
| TLA J1007-X | h |
| TLA J1007-Y | i |
| TLA J1007-Z | j |
| TLA J1007-b | k |
| TLA J1007-c | l |
| TLA J1007-d | m |
| TLA J1007-e | n |
| TLA J1007-f | p |
| TLA J1007-g | r |
| TLA J1007-h | s |
| TLA J1007-i | t |
| TLA J1007-l | u |
| TLA J1007-m | v |
| TLA J1007-n | w |
| TLA J1007-o | x |
| TLA J1007-p | y |
| TLA J1007-q | z |
| TLA J1007-r | 1 |
| TLA J1007-s | 2 |
| TLA J1007-t | 3 |
| TLA J1007-u | 4 |
| TLA J1007-v | 5 |
| GND | 6 |

SERVO CONT.
AX5130

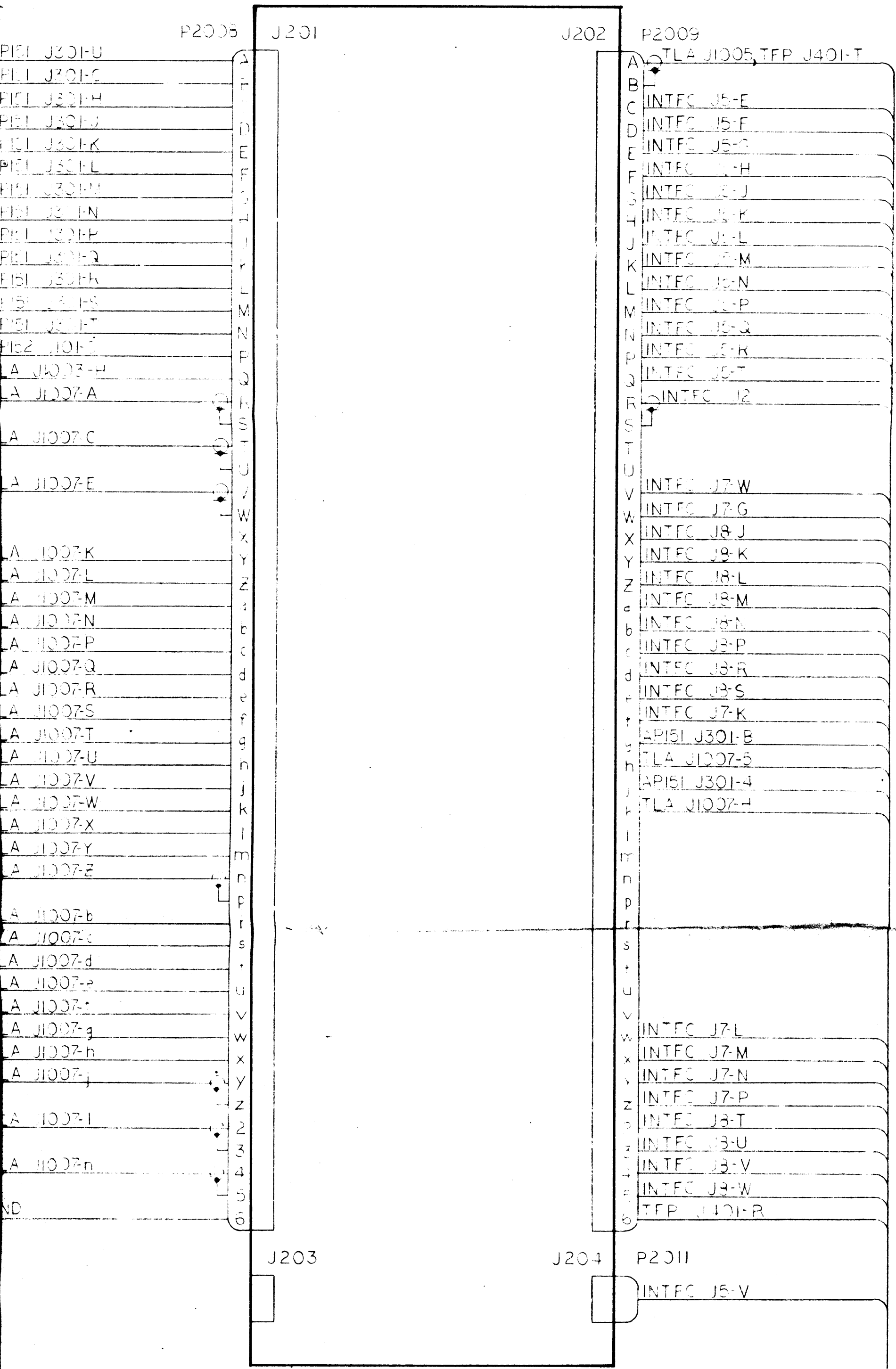

J202

P2009

TLA J1005, TFP J401-T

| | |
|---|-----------------------|
| A | TLA J1005, TFP J401-T |
| B | |
| C | INTEC J5-E |
| D | INTEC J5-F |
| E | INTEC J5-G |
| F | INTEC J5-H |
| G | INTEC J5-I |
| H | INTEC J5-J |
| I | INTEC J5-K |
| J | INTEC J5-L |
| K | INTEC J5-M |
| L | INTEC J5-N |
| M | INTEC J5-P |
| N | INTEC J5-Q |
| O | INTEC J5-R |
| P | INTEC J5-T |
| Q | INTEC J5-U |
| R | INTEC J5-V |
| S | |
| T | |
| U | |
| V | INTEC J7-W |
| W | INTEC J7-G |
| X | INTEC J8-J |
| Y | INTEC J8-K |
| Z | INTEC J8-L |
| a | INTEC J8-M |
| b | INTEC J8-N |
| c | INTEC J8-P |
| d | INTEC J8-R |
| e | INTEC J8-S |
| f | INTEC J7-K |
| g | API51 J301-B |
| h | TLA J1007-5 |
| i | API51 J301-4 |
| j | TLA J1007-H |
| k | |
| l | |
| m | |
| n | |
| p | |
| q | |
| r | |
| s | |
| t | |
| u | |
| v | |
| w | INTEC J7-L |
| x | INTEC J7-M |
| y | INTEC J7-N |
| z | INTEC J7-P |
| o | INTEC J8-T |
| p | INTEC J8-U |
| q | INTEC J8-V |
| r | INTEC J8-W |
| s | TFP J101-R |

J204

P2011

INTEC J5-V

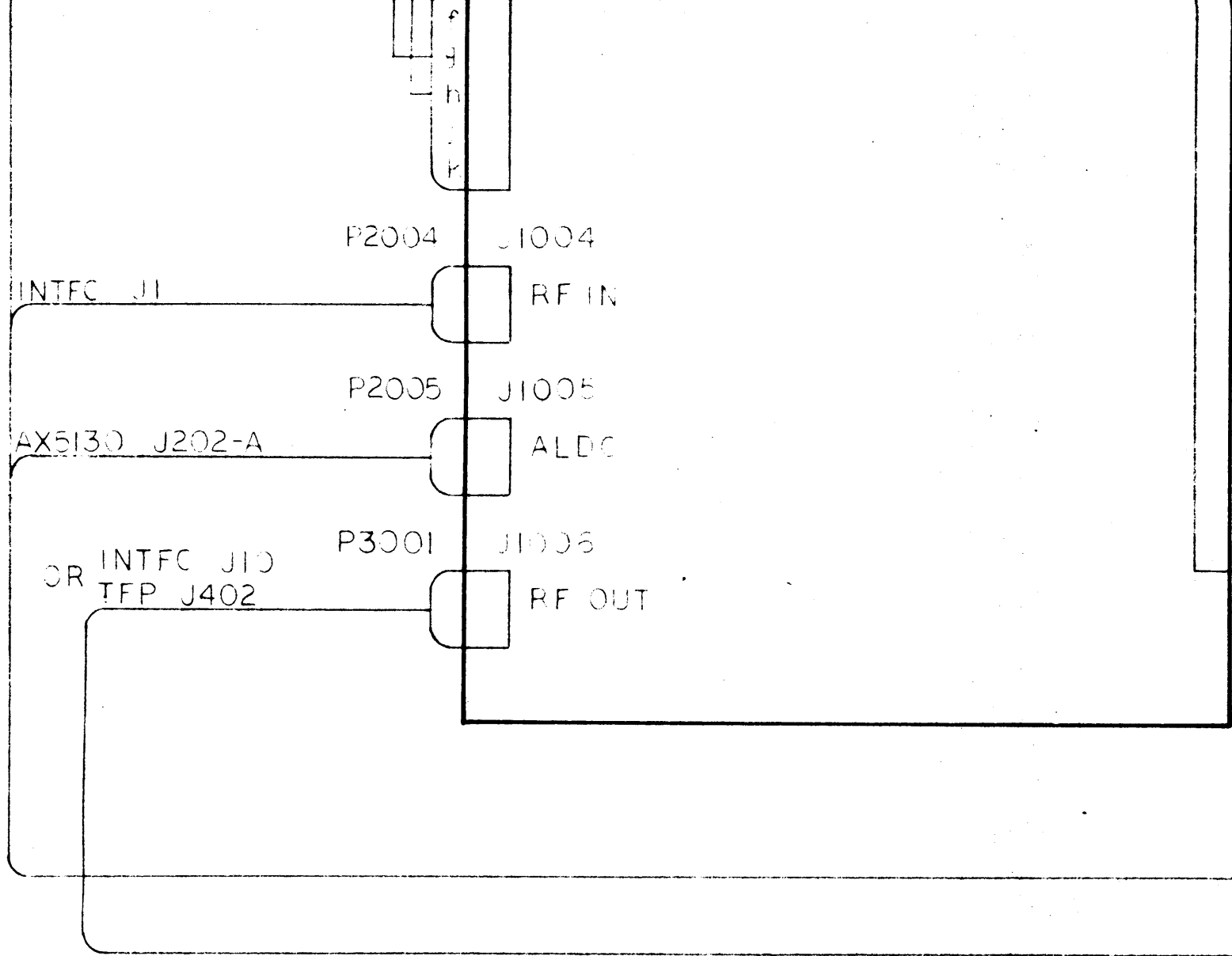

| | |
|---|---------------|
| P | API51 J301-I |
| r | API51 J301-T |
| s | TFP J401-K |
| t | TFP J401-J |
| u | TFP J401-H |
| v | TFP J401-G |
| w | TFP J401-F |
| x | TFP J401-E |
| y | TFP J401-D |
| z | TFP J401-C |
| 2 | TFP J401-B |
| 3 | TFP J401-A |
| 4 | AX5130 J202-H |
| 5 | TFP J401-S |
| 6 | |

| |
|--------------|
| 151 J301-I |
| 151 J301-T |
| P J401-K |
| P J401-J |
| P J401-H |
| P J401-G |
| P J401-F |
| P J401-E |
| P J401-D |
| P J401-C |
| P J401-B |
| P J401-A |
| K5130 J301-F |
| P J401-S |

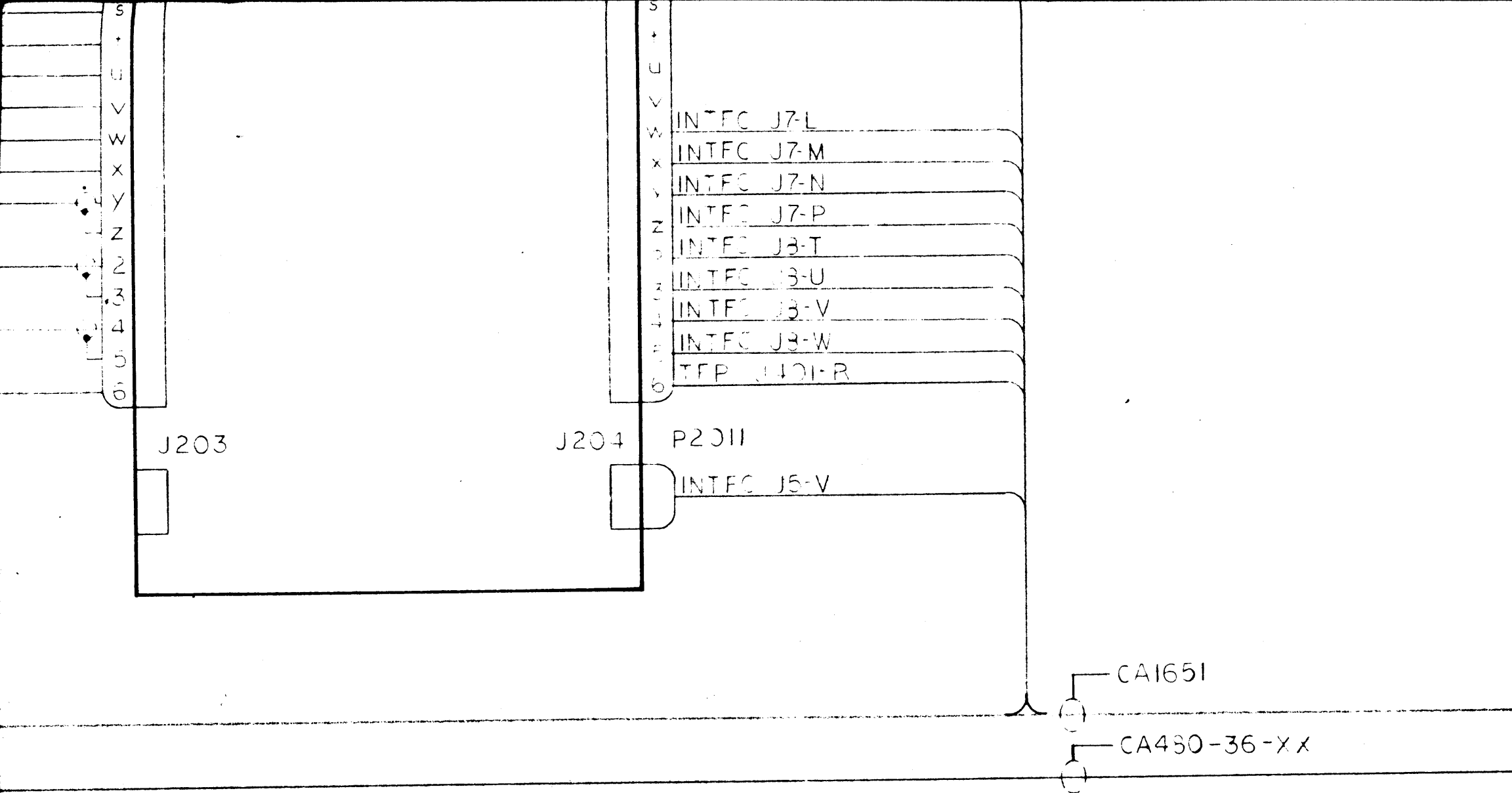

| NOTICE TO PERSONS RECEIVING THIS DRAWING | | | | QTY. REQ. | ITEM | PART NO. | DESC. |
|--|-------|------|------|------------------|-----------|------------|---------------|
| <p>THE TECHNICAL MATERIAL DISCLOSED HEREIN IS THE PROPERTY OF THE TECHNICAL SERVICES CORPORATION. THIS DRAWING IS ISSUED IN CONFIDENCE FOR ENGINEERING INFORMATION ONLY AND IS NOT TO BE REPRODUCED OR USED TO MANUFACTURE ANYTHING OTHER THAN THAT SPECIFICALLY AUTHORIZED BY THE TECHNICAL SERVICES CORPORATION IN ITS WRITING. THIS DRAWING IS LOANED FOR MUTUAL ASSISTANCE AND IS SUBJECT TO RECALL AT ANY TIME.</p> | | | | LIST OF MATERIAL | | | |
| NO | DRAFT | CHKD | APPD | QTY. | MODEL | ASSY. | THE TECHNICAL |
| | 01 | | | | HFTA-1KJ2 | RAK 138-1A | |
| | | | | FINAL APPROVAL | | DATE | |
| | | | | | | 280077 | |
| | | | | MECH. DES. | | DATE | |
| | | | | | | | |
| | | | | ELECT. DES. | | DATE | |
| | | | | | | 280077 | |
| | | | | CHECKED | | DATE | |
| | | | | | | | |
| | | | | DRAWN | | DATE | |
| | | | | | | 28 SEP 77 | |
| | | | | | | | |
| | | | | | | | |

HFTA-1KJ2

S
+
U
V
W
X
Y
Z
A
B
C
D
E
F
G
H
I
J
K
L
M
N
O

- INTEFC J7-L
- INTEFC J7-M
- INTEFC J7-N
- INTEFC J7-P
- INTEFC J8-T
- INTEFC J8-U
- INTEFC J8-V
- INTEFC J8-W
- TEP J401-R

J204 P2011

INTEFC J5-V

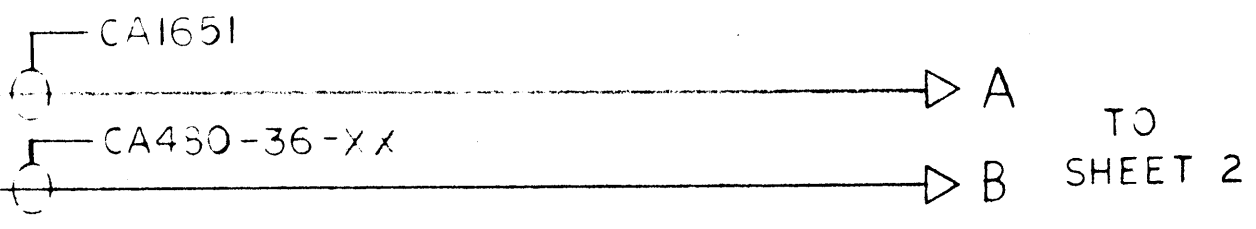

| | | | | | | |
|--|--|--------------------------------------|------|-------------------|-------------|--------|
| REPRODUCING THIS DRAWING without the written permission of THE TECHNICAL MATERIEL CORPORATION is prohibited and is subject to recall at any time. | | QTY. REQ. | ITEM | PART NO. | DESCRIPTION | SYMBOL |
| LIST OF MATERIAL | | | | | | |
| ASSY. RAK 138-1A | | FINAL APPROVAL <i>[Signature]</i> | | DATE 28 OCT 71 | | |
| | | MECH. DES. | | DATE | | |
| | | ELECT. DES. <i>[Signature]</i> | | DATE 28 OCT 71 | | |
| | | CHECKED | | DATE | | |
| | | DRAWN <i>[Signature]</i> | | DATE 28 SEP 71 | | |
| <p>THE TECHNICAL MATERIEL CORP.</p> <p>Figure 2-3</p> <p>HFTA-1KJ2 INTERCONNECT WIRING DIAGRAM</p> <p>(SHEET 1 OF 3)</p> <p>Page 2-8</p> | | | | | | |

P/O
INTERFACE

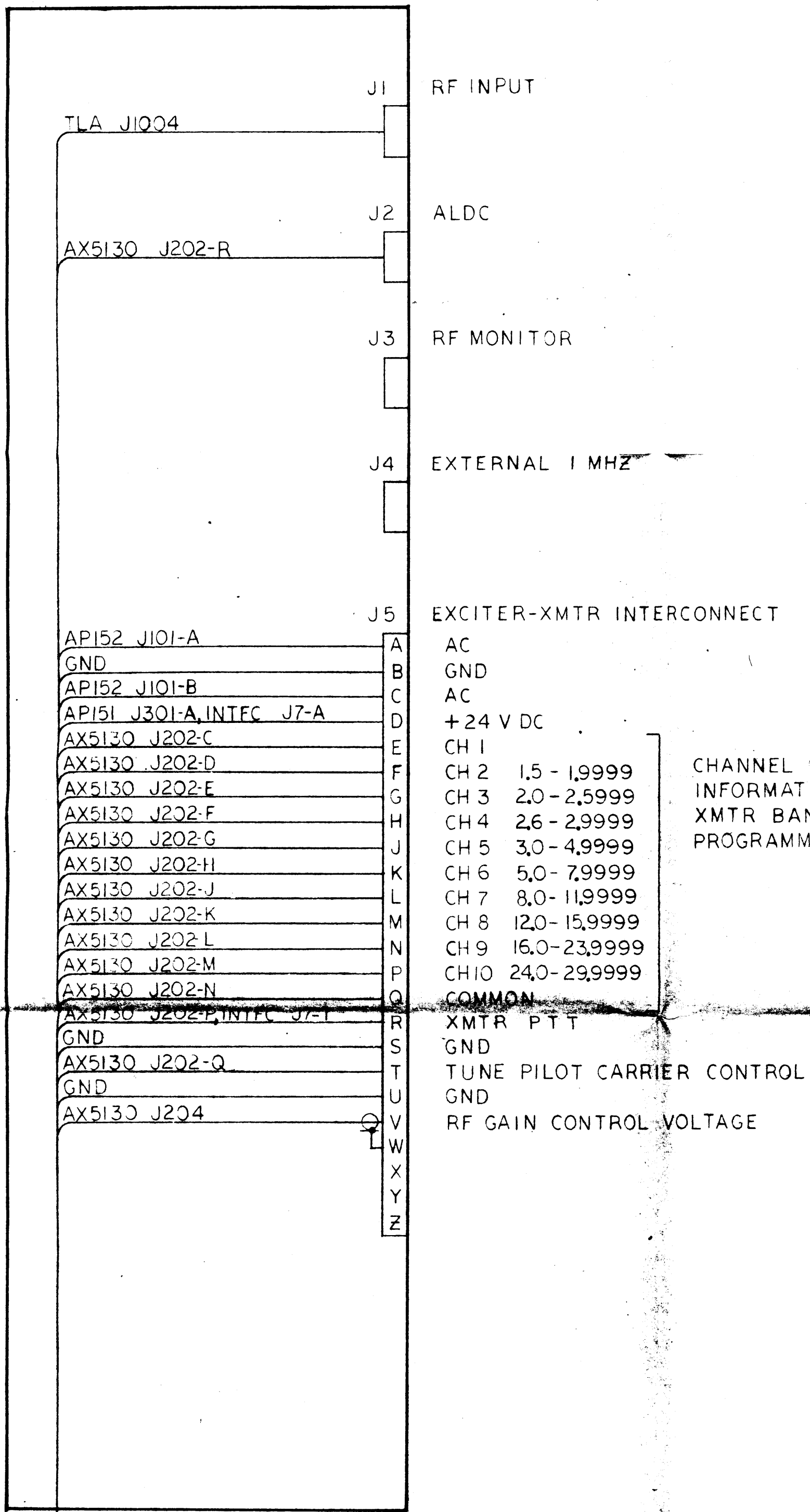

CHANNEL OR MHZ
INFORMATION FOR
XMTR BAND
PROGRAMMING

F/O
INTERFACE

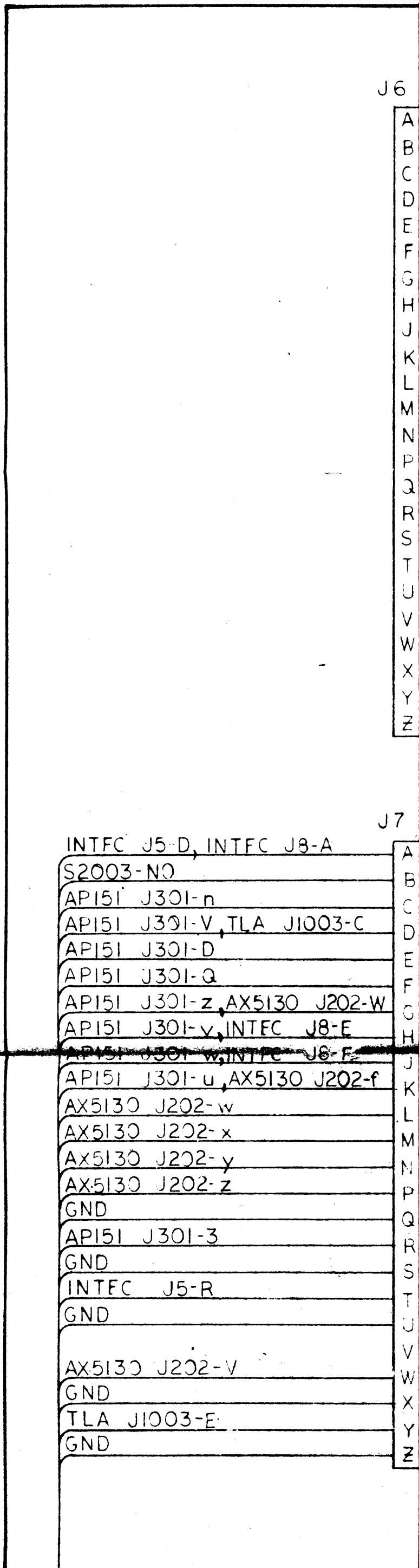

J6 EXCITER CONTROL

A
B
C
D
E
F
G
H
J
K
L
M
N
P
Q
R
S
T
U
V
W
X
Y
Z

J7 XMTR CONTROL

A
B
C
D
E
F
G
H
J
K
L
M
N
P
Q
R
S
T
U
V
W
X
Y
Z

+24 V DC
COM } EXTERNAL 1.
NO } INTERLOCKS
NC }
COM } OVERLOAD 2.
NO } RESET
NC } OVERLOAD 3.
NO } INDICATOR
AUTO RESET RECYCLE
1 } POWER
2 } LEVEL
3 } CONTROL
4 }
GND
HV ON
GND
XMTR PTT
GND
TUNE
GND
OUTPUT METER CONTROL
GND

IF EXTERNAL CONTROLS ARE NOT USED,
JUMP J7 PINS AS SHOWN.
XMTR PTT IS CONTROLLED BY J5-R,S OR J7-T,U.

OR MHz
TION FOR
AND
MING

L

P/O
INTERFACE

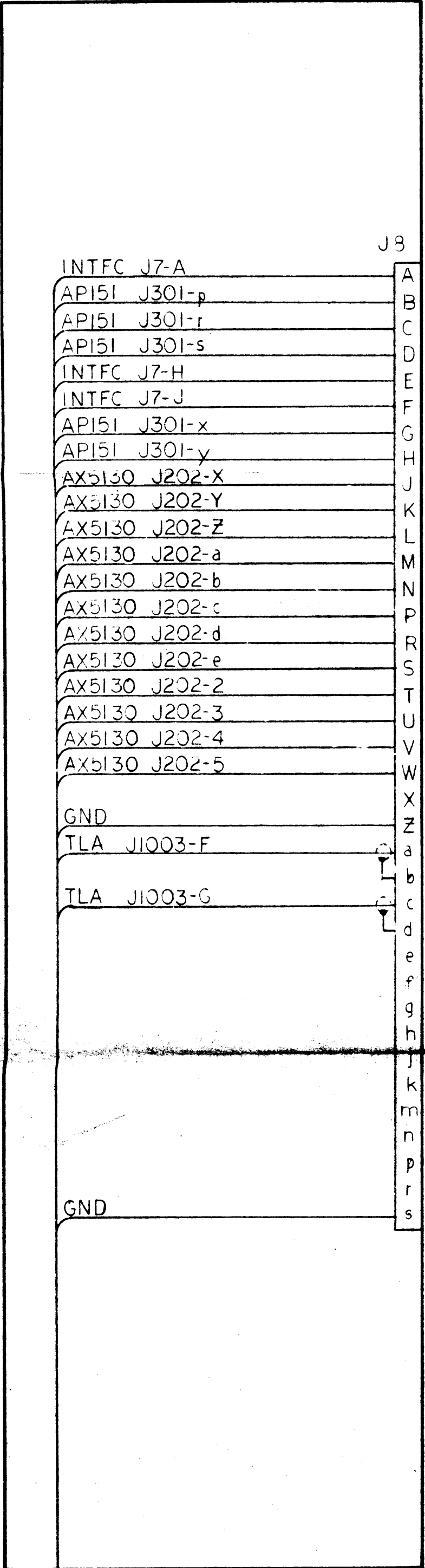

J8

XMTR READBACK

| | | |
|------|---------------------|-----------|
| | +24 V DC | |
| NO |] RECEIVER 5. | |
| COM | | MUTE |
| NC | | |
| NC |] OVERLOAD 3. | |
| NO | | INDICATOR |
| NC |] OVERLOAD 3. | |
| NO | | INDICATOR |
| | TUNING INDICATOR | |
| NC |] FAULT 4. | |
| NO | | INDICATOR |
| COM. | | |
| | READY INDICATOR | |
| | HV OFF INDICATOR | |
| | HV ON INDICATOR | |
| | NOT READY INDICATOR | |
| 1 |] POWER | |
| 2 | | LEVEL |
| 3 | | INDICATOR |
| 4 | | |
| | GND | |
| | FWD POWER | |
| | REFL POWER | |
| | GND | |

P/O
INTERFACE

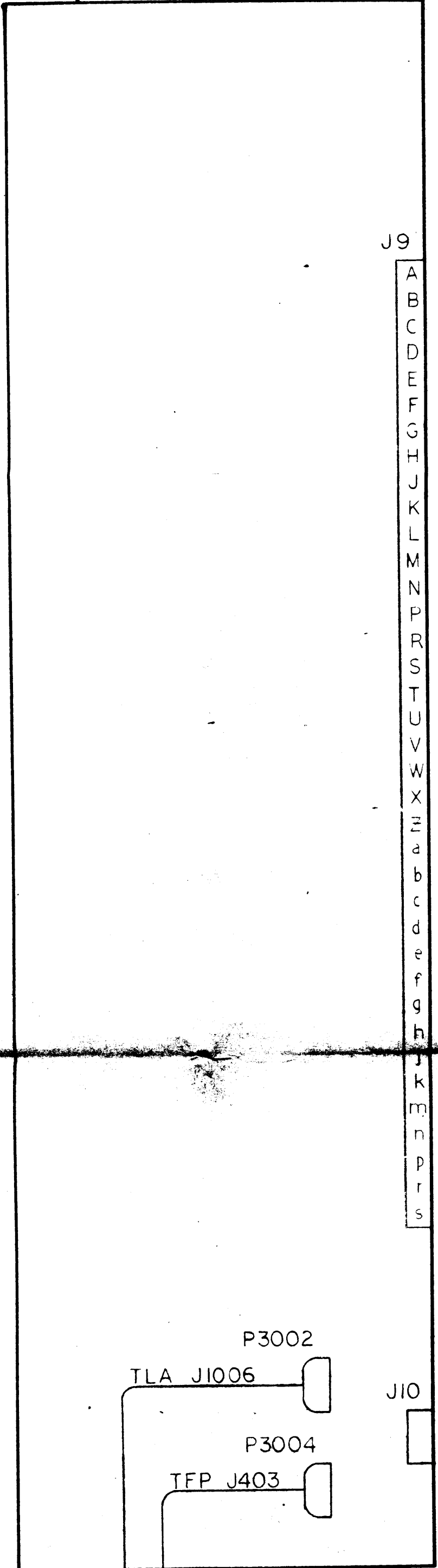

J9 ANTENNA TUNER

- A
- B
- C
- D
- E
- F
- G
- H
- J
- K
- L
- M
- N
- P
- R
- S
- T
- U
- V
- W
- X
- Y
- a
- b
- c
- d
- e
- f
- g
- h
- j
- k
- m
- n
- p
- r
- s

J10 RF OUTPUT

J9 ANTENNA TUNER

A
B
C
D
E
F
G
H
J
K
L
M
N
P
R
S
T
U
V
W
X
Y
Z
a
b
c
d
e
f
g
h
j
k
m
n
p
r
s

P3002

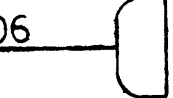

P3004

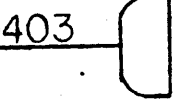

J10 RF OUTPUT



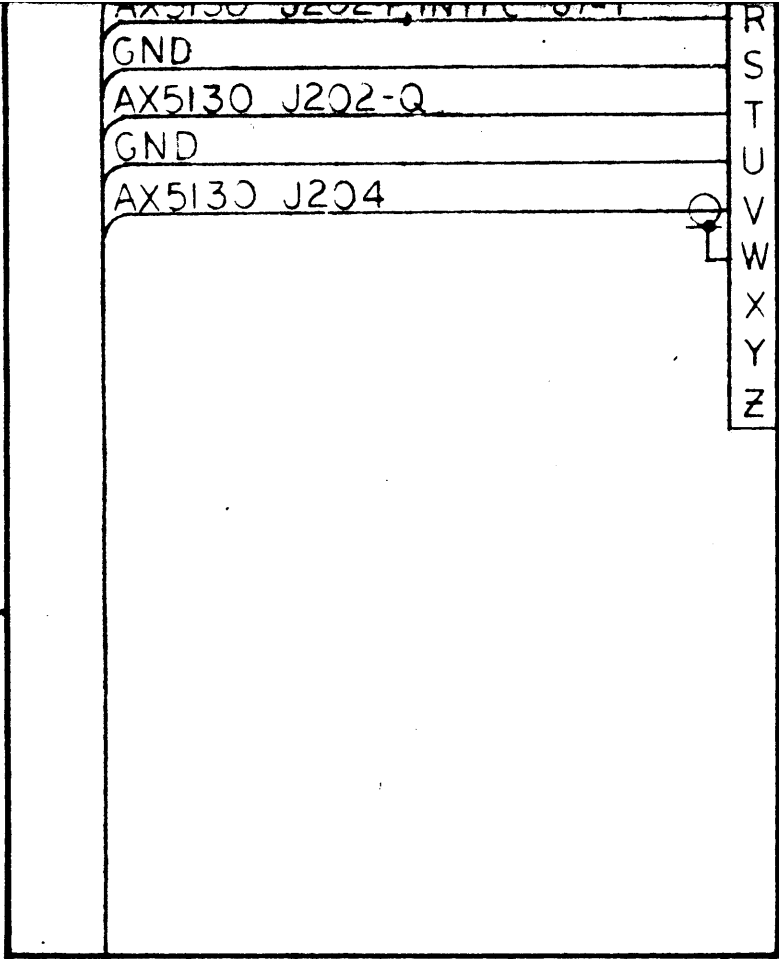

XMTR PTT
 GND
 TUNE PILOT CARRIER CONTROL
 GND
 RF GAIN CONTROL VOLTAGE

TO SHEET 1

A ←

B ←

1. INTERLOCK TERMINAL DESIGNATIONS ARE FOR INACTIVATED SWITCH.
2. OVERLOAD RESET TERMINAL DESIGNATIONS ARE FOR INACTIVATED SWITCH.
3. OVERLOAD INDICATOR TERMINAL DESIGNATIONS ARE FOR OVERLOAD CONDITION.
4. FAULT INDICATOR TERMINAL DESIGNATIONS ARE FOR FAULT CONDITION.
5. RECEIVER MUTE TERMINAL DESIGNATIONS ARE FOR XMTR OFF CONDITION.

CONTROL
PAGE

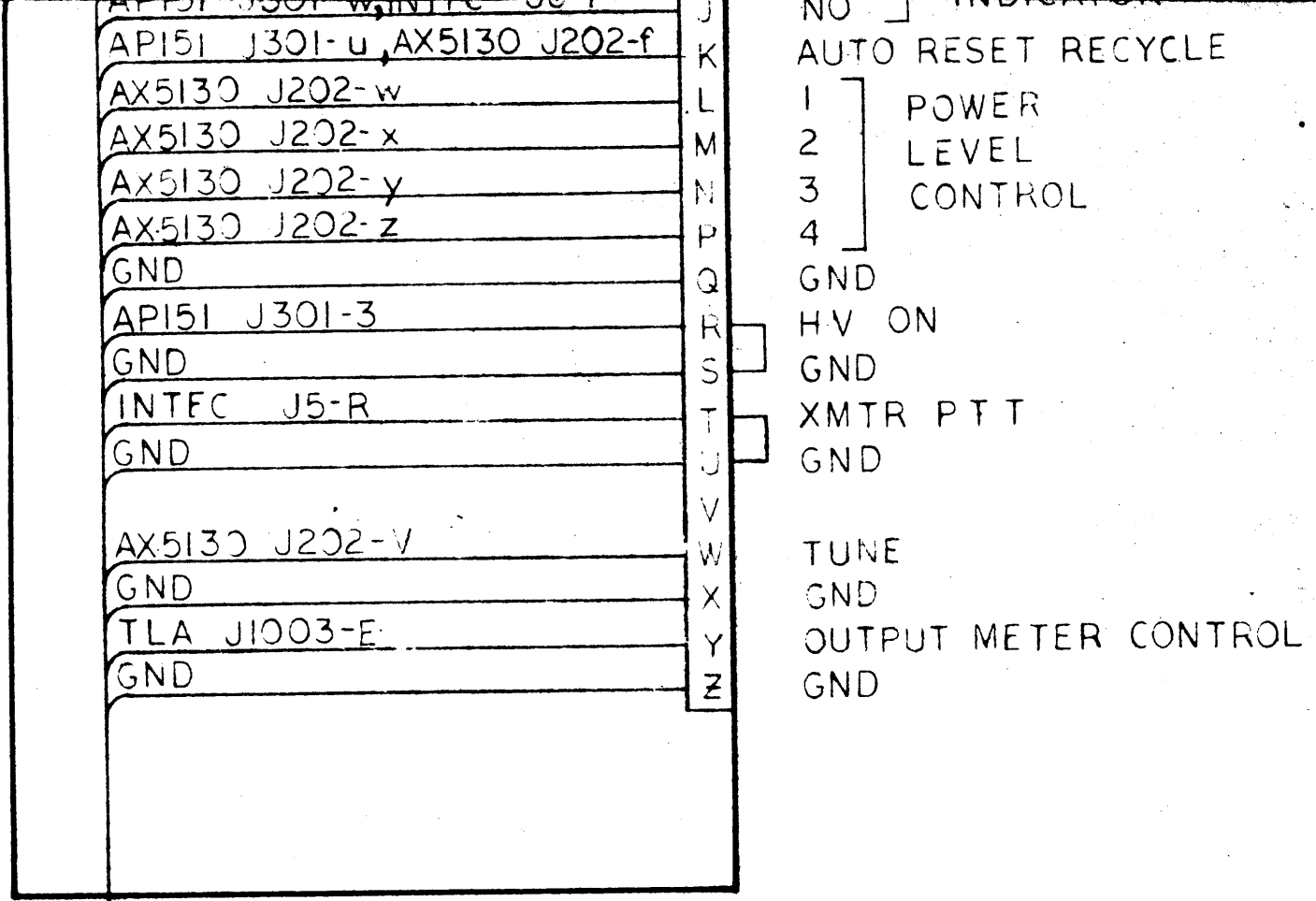

IF EXTERNAL CONTROLS ARE NOT USED,
JUMP J7 PINS AS SHOWN.
XMTR PTT IS CONTROLLED BY J5-R,S OR J7-T,U.

ED SWITCH.
CTIVATED SWITCH.
OVERLOAD CONDITION.
ULT CONDITION.
TR OFF CONDITION.

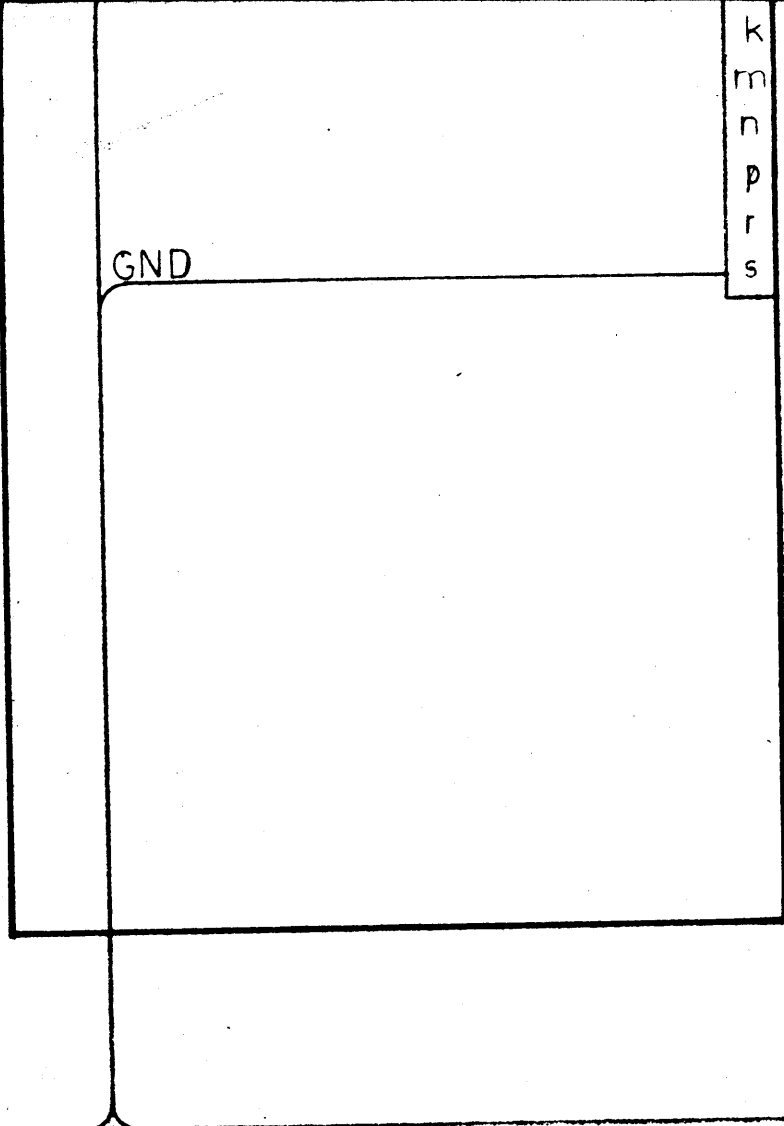

P3002 TO INTFC J10 IF TFP-1K IS NO
 P3002 TO TFP J402 IF TFP-1K IS PR

| Ø | ORIGINAL RELEASE FOR PRODUCTION | 11/71 | CW | | |
|---|---------------------------------|-------|----|--|--|
| | | | | | |

k
m
n
p
r
s

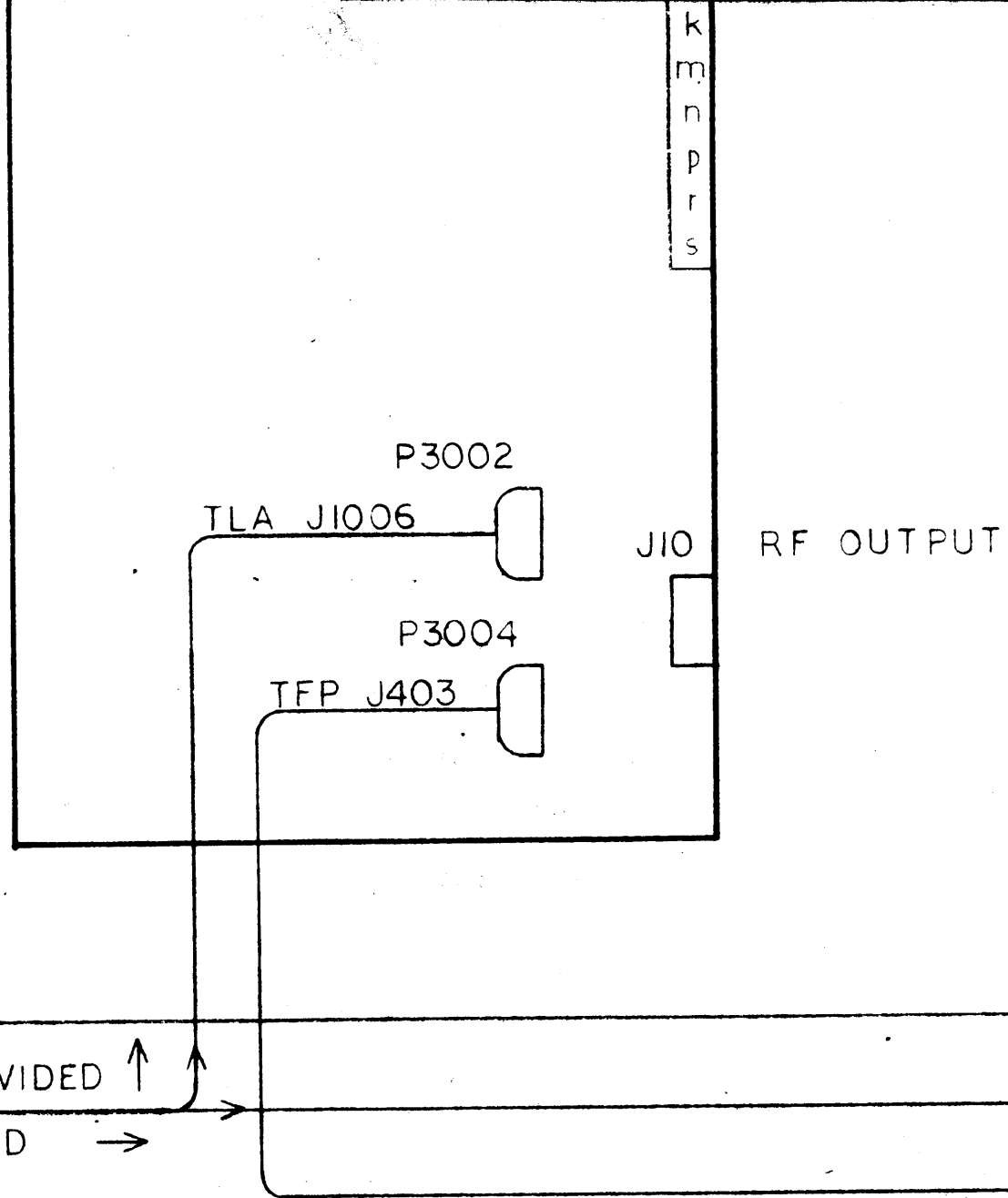

J10 RF OUTPUT IF TFP-1K IS NOT PROVIDED ↑
J402 IF TFP-1K IS PROVIDED →

| QTY | MODEL | ASSY. |
|-----|-----------|------------|
| | HFTA-1KJ2 | RAK 138-1A |

m
n
p
r
s

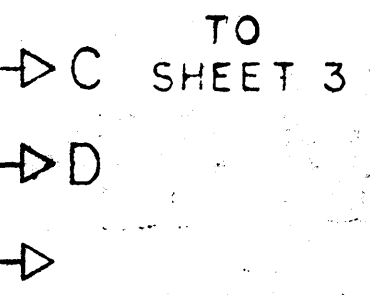
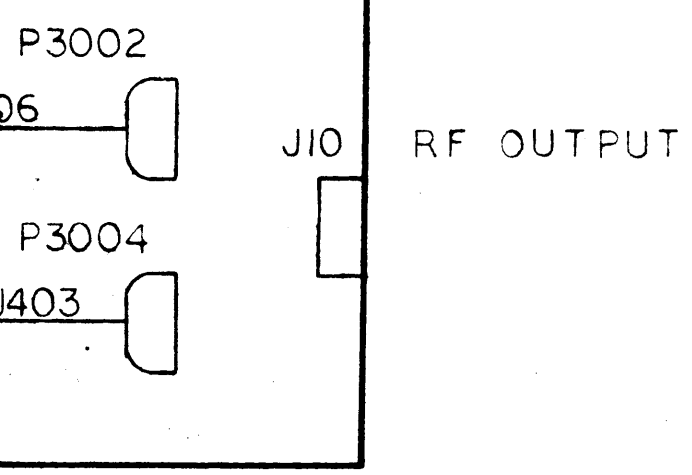

| | |
|-----|------------|
| L | ASSY, |
| KJ2 | RAK 138-1A |

Figure 2-3
HFTA-1KJ2 INTERCONNECT WIRING DIAGRAM
(SHEET 2 OF 3)

HARM. FILTER
TFP-1K (OPTIONAL)

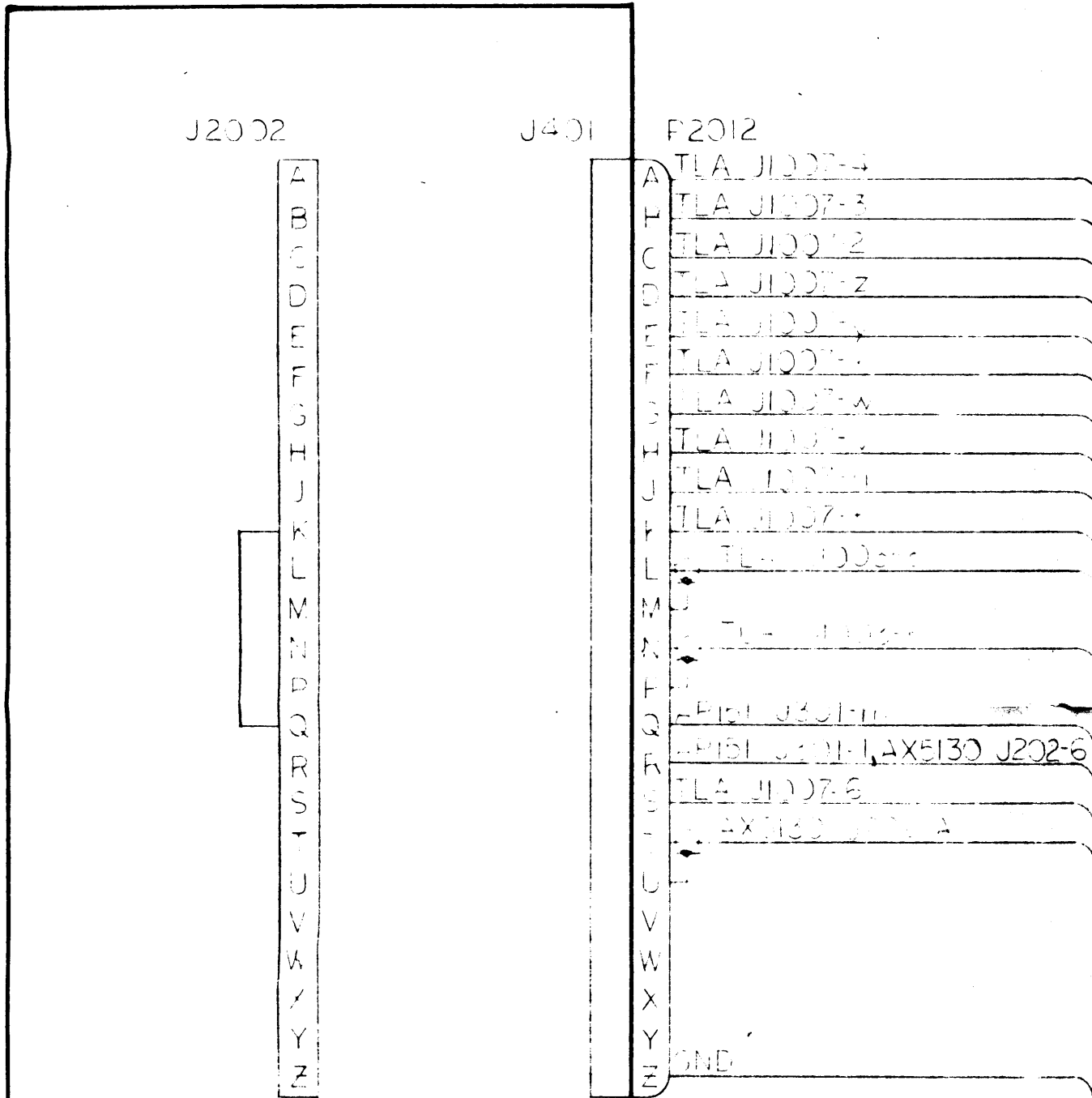

IF TFP-1K IS NOT PROVIDED,
J2002 IS MOUNTED ON CABINET
TO PROVIDE CONNECTION FOR
P2012.

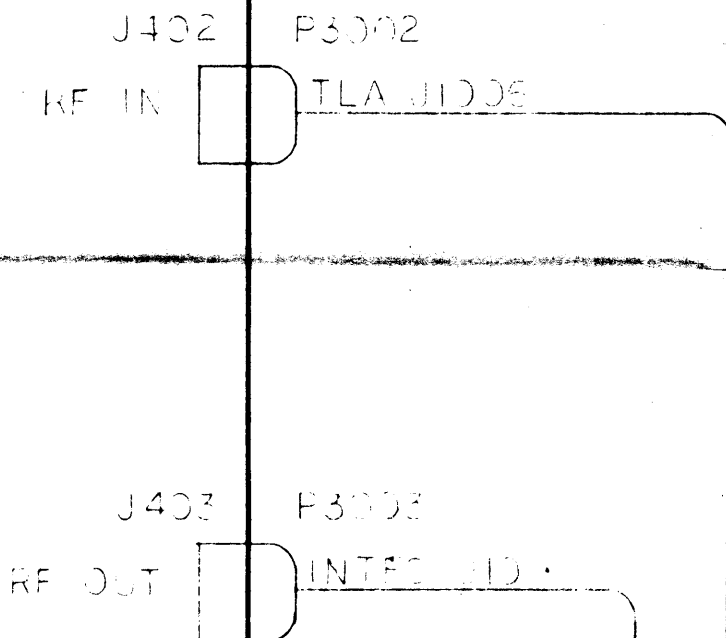

LV & BIAS SUP.
AP-151

J301

P2013

| | |
|---|----------------------------|
| A | INTFC J5-D |
| B | AX5130 J202-1 |
| C | AX5130 J201-E |
| D | API52 J101-F, INTEFC J7-E |
| E | API52 J101-H |
| F | API52 J101-M |
| G | API52 J101-N |
| H | AX5130 J201-C |
| I | AX5130 J201-D |
| J | AX5130 J201-E |
| K | AX5130 J201-F |
| L | AX5130 J201-G |
| M | AX5130 J201-H |
| N | AX5130 J201-I |
| O | AX5130 J201-J |
| P | AX5130 J201-K, INTEFC J7-F |
| Q | AX5130 J201-L |
| R | AX5130 J201-M |
| S | AX5130 J201-N, TLA J1003-B |
| T | AX5130 J201-O, TLA J1003-A |
| U | INTEFC J7-F, S2001-NC |
| V | TLA J1003-I |
| W | TLA J1003-K |
| X | TLA J1003-N |
| Y | TLA J1003-F |
| Z | TLA J1003-H |
| 1 | TLA J1003-R |
| 2 | TLA J1003-FA |
| 3 | TLA J1003-AS |
| 4 | TLA J1003-BS |
| 5 | TLA J1003-T |
| 6 | TLA J1003-T |
| 7 | TLA J1003-V |
| 8 | TLA J1003-W |
| 9 | TLA J1003-K |
| 0 | TLA J1003-T, TFP J401-R |
| 1 | TFP J401-Q |
| 2 | INTEFC J7-G |
| 3 | INTEFC J7-B |
| 4 | INTEFC J7-C |
| 5 | INTEFC J7-D |
| 6 | |
| 7 | INTEFC J7-E |
| 8 | INTEFC J7-F |
| 9 | INTEFC J7-G |
| 0 | INTEFC J7-H |
| 1 | INTEFC J7-I |
| 2 | INTEFC J7-J |
| 3 | INTEFC J7-K |
| 4 | INTEFC J7-L |
| 5 | INTEFC J7-M |
| 6 | INTEFC J7-N |
| 7 | TLA J1003-A |
| 8 | INTEFC J7-R |
| 9 | AX5130 J202-1 |
| 0 | |
| 1 | |
| 2 | |
| 3 | |
| 4 | |
| 5 | |
| 6 | |
| 7 | |
| 8 | |
| 9 | |

H.V. SUP.
AP-152

J7-E

J7-F

J1003

J1003-A

NC

J1-R

J101

P2014

J2001, INTEC J5-A

J2001, INTEC J5-C

GND

AP151 J301-D

AX5150 J201-F

AP151 J301-E

TLA J1001-U

TLA J1001-Y

TLA J1001-F

TLA J1001-E

AP151 J301-F

AP151 J301-G

R102

4 KV

TLA J1001

A103-E2

2 KV

TLA J1002

FC J5-A

FC J5-C

ED

DI-F

-E

-U

-Y

-Z

-A

-F

-G

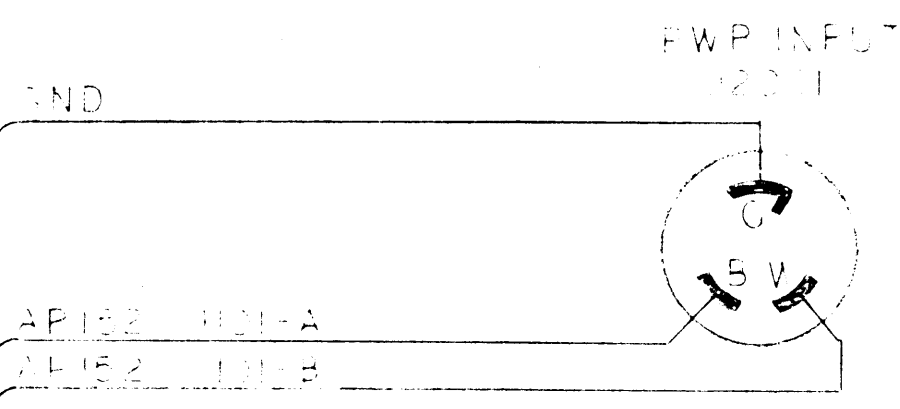
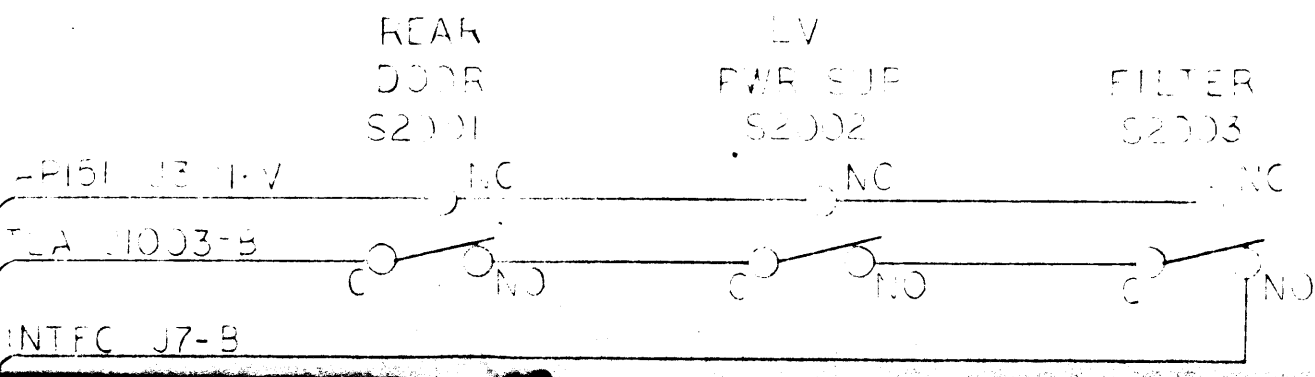

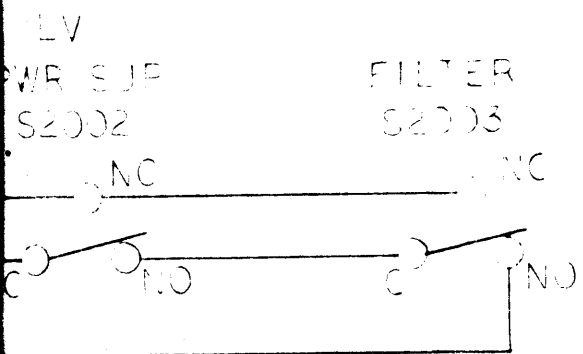

P INPUT
J2001



| LAST SYMBOLS | MISSING SYMBOLS |
|--|-----------------|
| J2002 P2014 S2003 P3004 | P2007, 2010 |
| J2002 } P3005 } OPTIONAL P3004 } | |

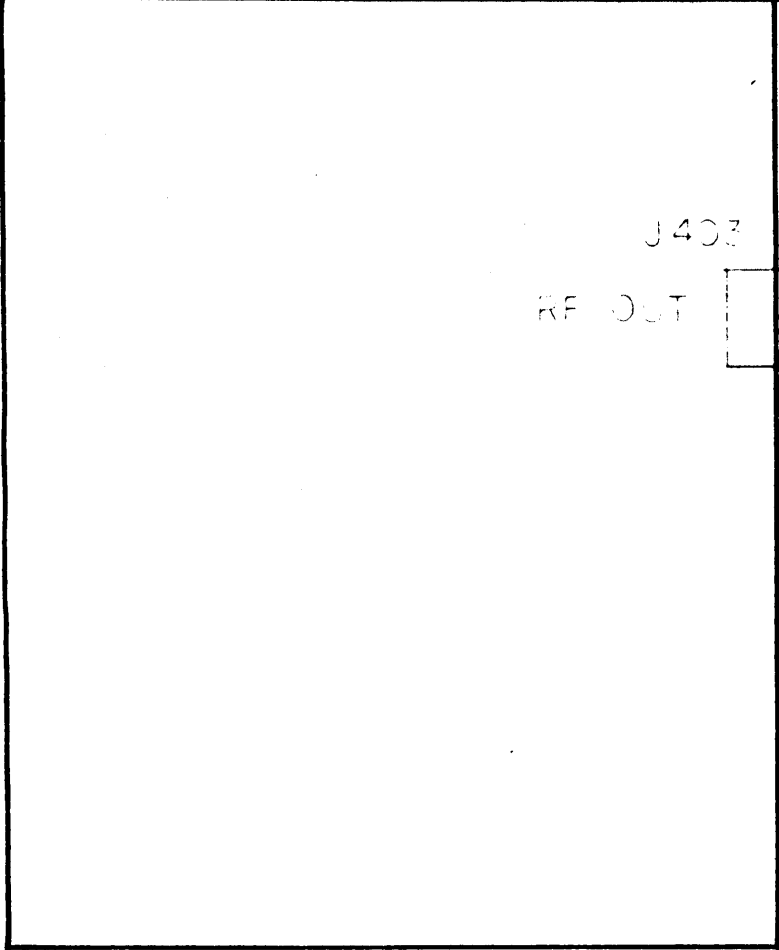

J403 F3003
RF OUT INTER ID.

T)
SHEET 2

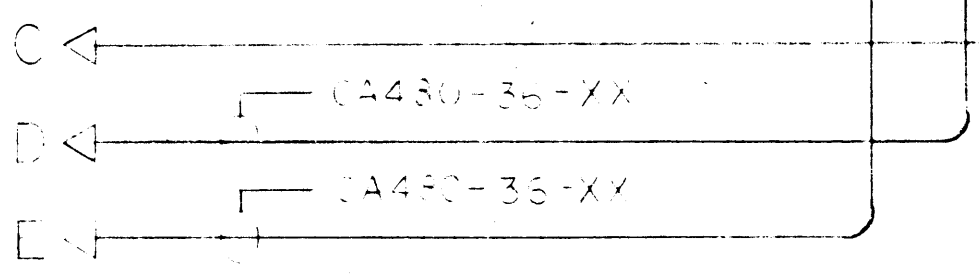

C
D
E

CA430-36-XX
CA450-36-XX

P INTER 23E

R INTER 23E

T INTER 23E

U INTER 23E

V INTER 23E

X INTER 23E

Y INTER 23E

Z INTER 23E

INTER 23E

INTER 23E

INTER 23E

EXHIBIT 1234

NO

NO

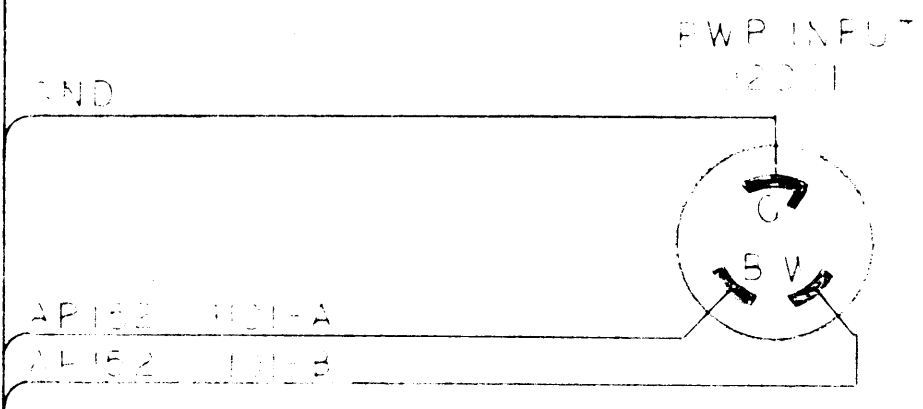

| REVISIONS | | | | | | NOTICE TO PERSONS RECEIVING THIS DRAWING | | | QTY. REQ. | ITEM | PART NO. |
|-----------|-------|----------|-------|------|------|---|-----------|-----------|-----------|------|----------|
| | DATE | E.M.N.NO | DRAFT | CHKD | APPD | THE TECHNICAL MATERIEL CORPORATION claims proprietary right in the material disclosed hereon. This drawing is issued in confidence for engineering information only and may not be reproduced or used to manufacture anything shown hereon without permission from THE TECHNICAL MATERIEL CORPORATION to the user. This drawing is loaned for mutual assistance and is subject to recall at any time. | | | | | |
| | 11/11 | | 01 | | | QTY | MODEL | ASS'Y. | | | |
| | | | | | | | FWTA-1KJ2 | RAK138-1A | | | |
| | | | | | | FINAL APPROVAL | | DATE | | | |
| | | | | | | | | 28 Oct 71 | | | |
| | | | | | | MECH. DES | | DATE | | | |
| | | | | | | | | | | | |
| | | | | | | ELECT. DES | | DATE | | | |
| | | | | | | | | 28 Oct 71 | | | |
| | | | | | | CHECKED | | DATE | | | |
| | | | | | | | | | | | |
| | | | | | | DRAWN | | DATE | | | |
| | | | | | | | | 28 Sep 71 | | | |

P INPUT
2071



| PERSONS RECEIVING THIS DRAWING | | QTY. REQ. | ITEM | PART NO. | DESCRIPTION | SYMBOL |
|---|--|--------------------|------|-------------------|-------------|--------|
| <p>THE TECHNICAL MATERIEL CORPORATION claims proprietary right in the material disclosed hereon. This information is for engineering information only and may not be reproduced or used without permission from THE TECHNICAL MATERIEL CORPORATION. The user assumes all responsibility for mutual assistance and is subject to recall at any time.</p> | | | | | | |
| EL | | | | | ASS'Y. | |
| -1KJ2 | | | | | RAK 138-1A | |
| FINAL APPROVAL | | <i>[Signature]</i> | | DATE 28 Oct 71 | | |
| MECH. DES. | | | | DATE | | |
| ELECT. DES. | | <i>[Signature]</i> | | DATE 28 Oct 71 | | |
| CHECKED | | | | DATE | | |
| DRAWN | | <i>[Signature]</i> | | DATE 28 Sep 71 | | |
| | | | | | | |
| | | | | | | |

LIST OF MATERIAL

THE TECHNICAL MATERIEL CORP.

Figure 2-3

HFTA-1KJ2 INTERCONNECT WIRING DIAGRAM

(SHEET 3 OF 3)

SECTION 3

OPERATOR'S SECTION

3-1. GENERAL

This section gives detailed operating instructions for the HFTA-1KJ2 Automated Transmitter. The operator should become thoroughly familiar with the location and function of each control on the individual units which comprise the HFTA-1KJ2. Although an extensive interlock and overload system is designed into the transmitter, a single incorrect control setting might still overload certain components, inviting early failure and consequently equipment "downtime", not to mention improper and illegal emission.

A definite operating sequence (as outlined in the operating instructions) should be strictly followed; the operator should establish a procedural pattern, thus insuring consistent operation.

3-2. OPERATING CONTROLS

For detailed functions of all operating controls and indicators on the HFTA-1KJ2, the operator should refer to the applicable technical manuals on the individual units which comprise the transmitter.

3-3. PRELIMINARY CONTROL SETTINGS

Before applying power to the transmitter, check that the antenna or dummy load connection is properly made at the output connector, (J10) located on the Interface Panel, and check that all controls on the transmitter are set in their proper position. These preliminary control settings are outlined in Table 3-1.

TABLE 3-1. PRELIMINARY CONTROL SETTINGS

| <u>Modular Unit</u> | <u>Control</u> | <u>Setting</u> |
|---------------------|-----------------------------------|--------------------|
| AP-152 | MAIN POWER circuit breaker | OFF |
| AP-151 | SCREEN and PLATE circuit breakers | OFF |
| | ALARM switch | down, off position |
| | * 1ST RF AMP BIAS control | fully clockwise |
| | * 2ND RF AMP BIAS control | fully clockwise |
| | * PA BIAS control | fully clockwise |

* NOTE: located within AP-151 drawer.

TABLE 3-1. PRELIMINARY CONTROL SETTINGS (continued)

| <u>Modular Unit</u> | <u>Control</u> | <u>Setting</u> |
|---------------------|-----------------------|-------------------------|
| MMX(A)-2 | ON/STANDBY switch | STANDBY |
| | CARRIER switch | 0 |
| | MODE switch | USB |
| | USB MIKE/LINE control | 0 |
| AX-5130 | RF GAIN control | counterclockwise |
| TLAA-1K | LOAD control | counterclockwise to "0" |

3-4. OPERATING PROCEDURES

a. Operating Procedures for Transmitter Tuning On Carrier

The HFTA-1KJ2 may be tuned on carrier either manually or automatically. The procedure for manual tuning is outlined in Table 3-2; the procedure for automatic tuning is outlined in Table 3-3. Before attempting to operate the HFTA-1KJ2, the control settings outlined in paragraph 3-3 should be completed.

TABLE 3-2. PROCEDURE FOR MANUAL TUNING ON CARRIER

| <u>Step</u> | <u>Modular Unit</u> | <u>Operation</u> | <u>Normal Indication</u> |
|-------------|---------------------|---|---|
| 1 | AP-152 | Place MAIN POWER breaker to ON position. | PA blower must operate and MAIN POWER indicator must illuminate. When the time delay cycle has been completed and if all safety interlocks are closed, the INTERLOCKS lamp on the AP-151 will illuminate. |
| 2 | AP-151 | Place SCREEN and PLATE breakers to ON position. | No indications at this time. |
| 3 | MMX(A)-2 | Set the ON/STANDBY switch to ON position. | POWER lamp will be illuminated. |
| 4 | | Set EXCITER switch to ON position. | No indications. |
| 5 | | Set frequency selector switches to the desired frequency. | No indications. |

TABLE 3-2. PROCEDURE FOR MANUAL TUNING ON CARRIER (continued)

| <u>Step</u> | <u>Modular Unit</u> | <u>Operation</u> | <u>Normal Indication</u> |
|-------------|---------------------|--|--|
| 6 | AX-5130 | Set AUTO/MAN switch to the MAN position (AUTO/MAN switch located within the AX-5130 drawer). | No indications. |
| 7 | TLAA-1K | Rotate the BAND switch (clockwise rotation only) to a band containing the desired frequency. | Band switch indicator for the selected band will illuminate. |

NOTE

The transmitter is equipped with protective overload circuitry. Additionally, the PA plate current meter (Ip) has an overload indicator which can be adjusted to trip at a value set by the operator. Should an overload occur, the meter face will illuminate.

| | | | |
|---|--|--|--|
| 8 | | Adjust the overload indicator adjustment screw for 800 ma on the Ip meter. | Plate current overload indicator will indicate 800 ma on the Ip meter. |
|---|--|--|--|

CAUTION

Before applying high voltage to the transmitter, insure that the RF GAIN control on the AX-5130 is fully counterclockwise.

| | | | |
|---|---------|--|--|
| 9 | AX-5130 | Press the HIGH VOLTAGE switch to light indicator (it may be necessary to press the HIGH VOLTAGE switch twice). | HIGH VOLTAGE switch indicator will illuminate red. |
|---|---------|--|--|

NOTE

For steps 10, 11, and 12 the BIAS controls are all located in the AP-151 drawer. Each individual amplifier has a bias level within the specified ranges, but peculiar to itself, in order for the amplifier to operate with minimum distortion (bias adjustments are not always necessary.)

TABLE 3-2. PROCEDURE FOR MANUAL TUNING ON CARRIER (continued)

| <u>Step</u> | <u>Modular Unit</u> | <u>Operation</u> | <u>Normal Indication</u> |
|--|---------------------|--|---|
| 10 | TLAA-1K | Set the Ip meter switch to 1ST AMP, and adjust the 1ST AMP BIAS control (located in AP-151) for between 60 to 80 ma on the Ip meter. | Ip meter will indicate quiescent current of 60 to 80 ma. |
| 11 | | Set the Ip meter switch to 2ND AMP, and adjust the 2ND AMP BIAS control (located in AP-151) for between 260 to 300 ma on the Ip meter. | Ip meter will indicate quiescent current of 260 to 300 ma on the Ip meter. |
| 12 | | Set the Ip meter switch to PA, and adjust the PA BIAS control (located in AP-151) for between 225 to 260 ma on the Ip meter. | Ip meter will indicate quiescent current of 225 to 260 ma. |
| <u>NOTE</u> | | | |
| During initial tuning of the transmitter, output power will be increased or decreased with the RF GAIN control located on the AX-5130. | | | |
| 13 | AX-5130 | Carefully adjust the RF GAIN control clockwise slightly to cause a noticeable increase in PA | Ip meter on the TLAA-1K will indicate an increase in meter reading (not to exceed 300 ma). |
| 14 | TLAA-1K | Adjust TUNE control for a peak on the OUTPUT meter. | The rotation of the TUNE control will cause the OUTPUT meter to indicate output. The peak on the OUTPUT meter should correspond with a dip on the Ip meter. |

TABLE 3-2. PROCEDURE FOR MANUAL TUNING ON CARRIER (continued)

| <u>Step</u> | <u>Modular Unit</u> | <u>Operation</u> | <u>Normal Indication</u> |
|-------------|---------------------|--|---|
| 15 | TLAA-1K | Depress and hold the REFL button. | OUTPUT meter will indicate reflected power. |
| 16 | TLAA-1K | Release the REFL button. | OUTPUT meter will indicate output power. |
| 17 | TLAA-1K | Carefully adjust the LOAD control clockwise from zero in slight increments causing an increase in PA plate current on the Ip meter. Readjust the TUNE control as per step 14. Continue to adjust the LOAD control clockwise in slight increments until there is no further increase in plate current. Back off slightly counter-clockwise with the LOAD control and readjust the TUNE control. | OUTPUT meter will indicate highest value when transmitter is properly tuned and loaded to match the impedance of the antenna or load. |

NOTE

If loading adjustment does not give proper response, return the LOAD control CCW to zero and repeat the adjustment.

| | | | |
|----|----------|--|---|
| 18 | AX-5130 | Rotate the RF GAIN control clockwise to increase output power to the desired level. If necessary, repeat step 17 and readjust with RF GAIN control until desired output is achieved. | OUTPUT meter on the TLAA-1K indicates the desired average power level; Ip meter on the TLAA-1K indicates the plate current. |
| 19 | MMX(A)-2 | Set CARRIER switch to FULL. | The OUTPUT meter indication on the TLAA-1K should drop to zero. |

NOTE

See paragraph 3-4b for intelligence operation.

TABLE 3-3. PROCEDURE FOR AUTOMATIC TUNING ON CARRIER

| <u>Step</u> | <u>Modular Unit</u> | <u>Operation</u> | <u>Normal Indication</u> |
|--|---------------------|--|---|
| 1 | AP-152 | Place MAIN POWER breaker to ON position. | PA blower must operate and MAIN POWER indicator must illuminate. When the time delay cycle has been completed and if all safety interlocks are closed, the INTERLOCKS lamp on the AP-151 will illuminate. |
| 2 | AP-151 | Place SCREEN and PLATE breakers to ON position. | No indications at this time. |
| 3 | MMX(A)-2 | Set the ON/STANDBY switch to ON position. | POWER lamp will be illuminated. |
| 4 | | Set the EXCITER switch to ON position. | No indications. |
| 5 | | Set frequency selector switches to the desired frequency. | No indications. |
| 6 | AX-5130 | Set AUTO/MAN switch to the manual position (AUTO/MAN switch located within the AX-5130 drawer). | No indications. |
| <u>NOTE</u> | | | |
| <p>The transmitter is equipped with protective overload circuitry. Additionally, the PA plate current meter (Ip) has an overload indicator which can be adjusted to trip at a value set by the operator. Should an overload occur, the meter face will illuminate.</p> | | | |
| 7 | TLAA-1K | Adjust the overload indicator adjustment screw for 800 ma on the Ip meter. | Plate current overload indicator will indicate 800 ma on the Ip meter. |
| 8 | AX-5130 | Press the HIGH VOLTAGE switch to light indicator (it may be necessary to press the HIGH VOLTAGE switch twice). | HIGH VOLTAGE switch indicator will illuminate red. |

TABLE 3-3. PROCEDURE FOR AUTOMATIC TUNING ON CARRIER (continued)

| <u>Step</u> | <u>Modular Unit</u> | <u>Operation</u> | <u>Normal Indication</u> |
|-------------|---------------------|------------------|--------------------------|
|-------------|---------------------|------------------|--------------------------|

NOTE

For steps 9, 10 and 11 the BIAS controls are all located in the AP-151 Drawer. Each individual amplifier has a bias level within the specified ranges, but peculiar to itself, in order for the amplifier to operate with minimum distortion.

| | | | |
|----|---------|--|---|
| 9 | TLAA-1K | Set the Ip meter switch to 1ST AMP, and adjust the 1ST AMP BIAS control (located in AP-151) for approximately 60 to 80 ma on the Ip meter. | Ip meter will indicate quiescent current of 60 to 80 ma. |
| 10 | | Set the Ip meter switch to 2ND AMP, and adjust the 2ND AMP BIAS control (located in AP-151) for between 260 to 300 ma on the Ip meter. | Ip meter will indicate quiescent current of 260 to 300 ma. |
| 11 | | Set the Ip meter switch to PA, and adjust the PA BIAS control (located in AP-151) for between 225 to 260 ma. | Ip meter will indicate quiescent current of 225 to 260 ma. |
| 12 | AX-5130 | Set the POWER LEVEL switch to the position for the desired output power level. Set AUTO/MANUAL switch to AUTO position. | No indications. |
| 13 | | Press the TUNE button to initiate automatic tuning. | Automatic tuning cycle will begin. Transmitter will drive up to tuning level (300 ma) and SERVO lamp will light and sequentially SEARCH and OPERATE lamps will light. The output meter will momentarily indicate the selected power level and then drop to zero. The READY indicator will be illuminated (green). |

NOTE

If the transmitter is already tuned automatically to a particular frequency and if the operator wishes to retune automatically on a different frequency, the operator should proceed as follows:

TABLE 3-3. PROCEDURE FOR AUTOMATIC TUNING ON CARRIER (continued)

| <u>Step</u> | <u>Modular Unit</u> | <u>Operation</u> | <u>Normal Indication</u> |
|-------------|---------------------|---|---|
| 1 | AX-5130 | Press the TUNE button. | READY lamp will extinguish. RF GAIN control will automatically drive CCW to minimum. |
| 2 | | Set the POWER LEVEL selector switch to the position for the desired output power level. | No indication. |
| 3 | MMX(A)-2 | Set the frequency selector switches to the desired output frequency. | No indication. (However, when AUTO/MANUAL switch is set to AUTO automatic bandswitching may occur dependent of frequency selected. |
| 4 | AX-5130 | Push TUNE button a second time to initiate automatic tuning. | Automatic tuning cycle will begin. Transmitter will drive up to tuning level (300 ma) and SERVO lamp will light and sequentially SEARCH and OPERATE lamps will light. The output meter will momentarily indicate the selected power level and then drop to zero. The READY indicator will be illuminated (green). |

b. Operating Procedures for Intelligence Modes

Once the transmitter has been tuned on carrier, either manually or automatically, it is ready for operation in its various intelligence modes. The mode selection, degree of carrier insertion, and intelligence levels are controlled by the operation of the MMX(A)-2 exciter unit. For operation of the exciter in its various modes, the operator should refer to the technical manual for the MMX(A)-2. However, when operating the multimode exciter in its intelligence modes to drive the amplifier stages of the transmitter, the operator should be thoroughly familiar with procedures for determining the output power of the transmitter for proper operation. The output power of the transmitter is monitored on the OUTPUT meter located on the front panel of the linear power amplifier, TLAA-1K. This OUTPUT meter reads average power. The transmitter is conservatively rated as being capable of delivering a maximum output of 1,000 watts PEP (peak envelope power) or average power. A clarification of the transmitter's output power rating is provided in this section to insure that the operator has a complete understanding of this rating, thus, insuring proper operation of the transmitter.

When the transmitter was tuned on carrier to full output power or to a selected power level (dependent upon POWER LEVEL switch position, i.e. 1-150 watts, 2-400 watts, 3-800 watts, 4-1000 watts), the amplifier was

driven to that power level and that same power level was indicated on the OUTPUT meter. The peak envelope power and average power were equal, since all of the power was contained in a single tone, the carrier. In multitone or voice transmission, however, the peak envelope power and average power are not equal. The peak envelope power is derived from the addition of the carrier voltage and the voltage of each individual tone when the carrier and tones are in phase, or at the crest of the modulation wave. The transmitter is capable of providing 1,000 watts PEP in all intelligence modes; however, the average power, the power which is monitored by the OUTPUT meter, will be decreased in a multitone transmission: The more tones (teletype tones, carrier, voice, etc.) which are being transmitted, the less average power, as indicated on the OUTPUT meter. Figure 3-1 shows average power (measured in percent of peak envelope power) as a function of the number of tones being transmitted.

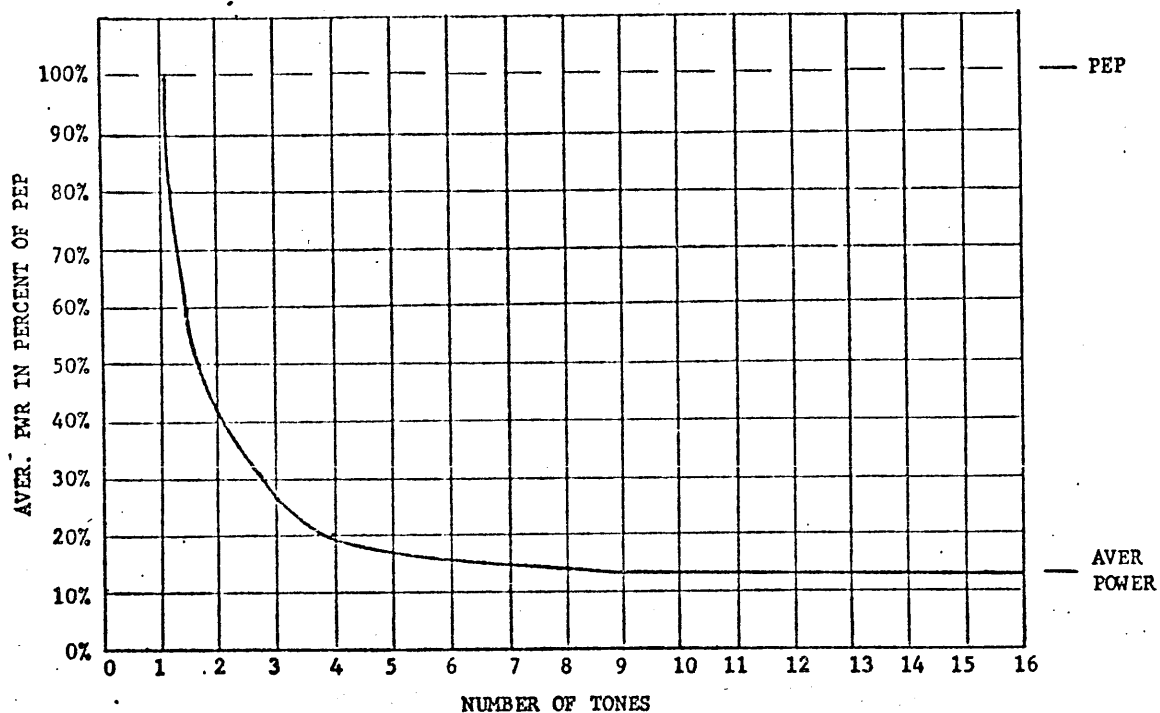

Figure 3-1. Ratio of Average Power and PEP
As a Function of Tones

Two typical examples of proper operation, utilizing the relationship shown in figure 3-1, are given as follows:

(1) An A3J transmission of two teletype tones at the position 4 power level (1,000 watts PEP): The MMX(A)-2 MODE switch should be in the USB position and the CARRIER SUPPRESSION switch in the FULL position, providing full suppression of carrier. The transmission contains two tones, and by reference to figure 3-1 the maximum average power should be approximately 50% of the 1,000 watt PEP, or 500 watts average. The USB audio level control on the MMX(A)-2 should be adjusted so that the transmitter OUTPUT meter reads approximately 500 watts average.

(2) A3H transmission of voice at the position 3 power level (800 watts PEP): The MMX(A)-2 MODE switch should be in the USB position and the CARRIER SUPPRESSION switch in the 6 db position, providing carrier

suppression of 3 to 6 db from PEP, or approximately 200 watts ($\frac{1}{4}$ power).

PEP is derived from the addition of carrier voltage and tone voltages. With carrier suppressed 6 db from PEP, the carrier voltage is already one half of the total voltage at PEP. The sum of the tone voltages must not exceed the remaining one half of the total voltage at PEP. Similarly, since the carrier voltage and the voltage available for tones are equal, so are the carrier power and the total tone power available. A maximum of approximately 200 watts PEP is available for tone transmission.

A voice transmission contains an infinite number of tones, and by reference to figure 3-1, the average power for an infinite number of tones should be approximately 10% of the PEP available for tone transmission, or 10% of 200 watts (20 watts). The CARRIER SUPPRESSION switch in the 6 db position will provide approximately 200 watts on the transmitter OUTPUT meter, and the USB audio level control on the MMX(A)-2 should be adjusted so that the transmitter OUTPUT meter reads approximately 220 watts average (the addition of carrier and intelligence power).

It is important that the exciter's intelligence levels be adjusted properly for the approximate average power on the OUTPUT meter, so that the transmitter's peak envelope power rating will not be exceeded. The transmitter also features automatic load and drive control (ALDC) circuits, which perform the function of limiting the exciter output during high modulation peaks, so that the transmitter's PEP will not be exceeded. There is a separate ALDC circuit for each of the four power levels. In general, each circuit is adjusted to limit at the maximum PEP of the associated power level (150 watts, 400 watts, 800 watts, and 1,000 watts). For adjustment of ALDC controls, refer to section 5.

3-5. EMERGENCY OPERATION

The HFTA-1KJ2 transmitter is an automated transmitter; however, under emergency conditions, when a failure in the automatic tuning circuitry has occurred, the transmitter may be manually tuned (refer to manual tuning procedure in paragraph 3-4). Under emergency conditions, when a failure of the MMX(A)-2 has occurred, CW keying of the HFTA-1KJ2 can be accomplished by connecting a signal generator to the signal input of the TLAA-1K amplifier. Keying of the signal generator will provide emergency CW transmission at the signal generator frequency.

NOTE

The signal generator frequency and output power should be within the range normally provided by the MMX(A)-2.

SECTION 4

PRINCIPLES OF OPERATION

4-1. GENERAL

The High Frequency Synthesized Transmitter Model HFTA-1KJ2 consists of two major units that form a one kilowatt high frequency transmitter. These major units are listed as they appear in figure 1-1:

RF Linear Power Amplifier, HFLA-1K
Multi-mode Exciter, MMX(A)-2

Principles of operation presented in this section will discuss the units listed above on a block diagram level and only to the extent that it effects the overall transmitting system.

Refer to the associated technical manuals for detailed principles of operation for the MMX(A)-2 Exciter and HFLA-1K High Frequency Linear Amplifier.

4-2. OVERALL BLOCK DIAGRAM DISCUSSION

Figure 4-1 is an overall block diagram of the HFTA-1KJ2 Transmitter which illustrates a MMX Exciter driving a HFLA-1K Linear Power Amplifier. The linear amplifier portion of the HFTA-1KJ2 provides 1 kilowatt peak envelope power or 1 kilowatt average power. Additionally the HFLA-1K features rapid automatic tuning with manual override and preset Power Level selection (4 selections).

Operating frequency selection is accomplished with use of six frequency selector switches together with a digital readout for each selector switch.

When the transmitter is in the auto tuning mode of operation, the exciter frequency selectors provide information for TLAA-1K automatic band-switch positioning.

In the PTT mode of operation when the push-to-talk switch on a handset or microphone is pressed, the exciter microphone circuit is completed and a ground is applied to the push-to-talk line when in the push-to-talk mode. The push-to-talk ground is extended to the push-to-talk relay of the HFLA-1K.

Audio from the microphone circuit is fed to the sideband input of the exciter.

The exciter accepts intelligence inputs and provides excitation voltage to the HFLA-1K.

In the auto tune mode of operation the exciter provides a transmitter tune carrier at the desired operating frequency. This tune carrier is utilized by the HFLA-1K for automatic tuning. Once the auto tune cycle is completed the tune carrier is removed and the intelligence applied to the exciter is transmitted in the emission mode selected.

The HFLA-1K provides an ALDC feedback voltage to the MMX(A)-2 Exciter which prevents the output power from exceeding a pre-set power level. The ALDC circuit in the exciter automatically compensates for high modulation peaks and load changes, providing a relatively constant output level.

The Transmitter is adaptable for external control operation, and accepts external inputs to provide the following control functions: high voltage ON/OFF, overload reset, external interlocks and external 1 MHz.

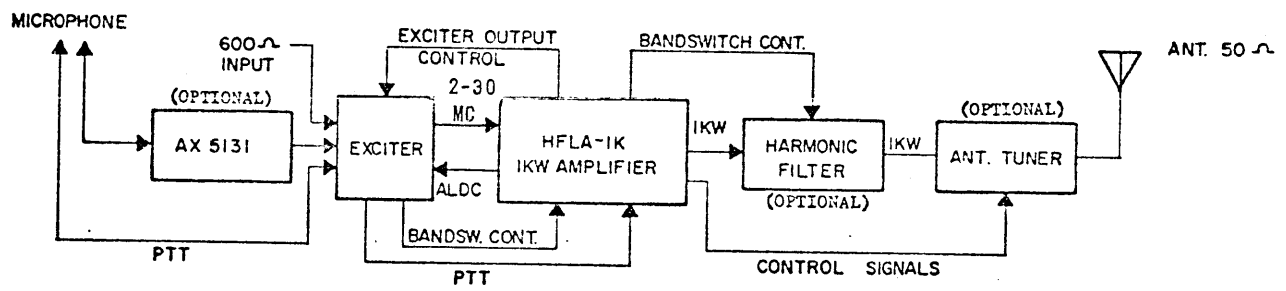

Figure 4-1. Functional Block Diagram
HFTA-1KJ2 Transmitter

SECTION 5

MAINTENANCE AND TROUBLESHOOTING

5-1. INTRODUCTION

The HFTA-1KJ2 has been designed for long term, trouble-free operation. When it becomes necessary to perform alignment and/or adjustments to the equipment, it is recommended that technicians perform the necessary operations outlined in the associated HFLA-1K and MMX(A)-2, technical manuals. The following maintenance aids are provided for troubleshooting and replacement of parts.

- a. Functional block diagram (Section 4, figure 4-1).
- b. Interconnect Wiring Diagram (Section 2, figures 2-2 and 2-3).

5-2. TEST EQUIPMENT REQUIRED

Table 5-1 lists the test equipment required for maintaining and troubleshooting the transmitter. Refer to the modular units technical manuals for additional equipment required to maintain and troubleshoot the modular components.

TABLE 5-1. TEST EQUIPMENT REQUIRED

| <u>EQUIPMENT</u> | <u>TYPE</u> |
|------------------|--|
| Signal Generator | Hewlett-Packard Model 606A, or equivalent |
| VTVM | Hewlett-Packard Model 410B, or equivalent |
| Multimeter | Simpson Model 260, or equivalent |
| Oscilloscope | Tektronix, Model 541A, or equivalent |

5-3. OPERATOR'S MAINTENANCE PROCEDURE

- a. Refer to transmitter operating procedure (Tables 3-2 and 3-3).
- b. Refer to troubleshooting (paragraph 5-5).
- c. Refer to maintenance procedures described in the HFLA-1K and MMX(A)-2.

5-4. PREVENTIVE MAINTENANCE

In order to prevent equipment failure due to dust, dirt or other destructive elements, it is suggested that a schedule of preventive maintenance be set up and adhered to. At periodic intervals, the equipment should be pulled out on its slides for internal cleaning and inspection. The wiring and all components should be inspected for dirt, dust, corrosion, grease or other harmful conditions. Remove dust with a soft brush or vacuum cleaner. Remove dirt or grease with any suitable cleaning solvent. Use of carbon tetrachloride should be avoided due to its highly toxic effects. Trichlorethylene or Methyl Chloroform may be used, providing the necessary precautions are observed. For detailed preventive maintenance procedures, refer to the applicable technical manuals.

WARNING

WHEN USING TOXIC SOLVENTS, MAKE CERTAIN THAT ADEQUATE VENTILATION EXISTS. AVOID PROLONGED OR REPEATED BREATHING OF THE VAPOR. AVOID PROLONGED OR REPEATED CONTACT WITH SKIN. FLAMMABLE SOLVENTS SHALL NOT BE USED ON ENERGIZED EQUIPMENT OR NEAR ANY EQUIPMENT FROM WHICH A SPARK MAY BE RECEIVED. SMOKING, "HOT WORK", ETC. IS PROHIBITED IN THE IMMEDIATE AREA.

CAUTION

When using trichlorethylene, avoid contact with painted surfaces, due to its paint-removing effects.

5-5. TROUBLESHOOTING

Troubleshooting the HFTA-1KJ2 transmitter consists of isolating faults to either the MMX(A)-2 Exciter or the HFLA-1K Power Amplifier. Refer to the associated technical manuals for detailed troubleshooting procedures of the modular units. Refer to operator's section for normal indications.

a. Disconnect the MMX rf output from the HFLA-1K and connect the MMX to a 50 ohm, 1 watt, non-inductive dummy load. Use an oscilloscope to monitor the exciter output, referring to the MMX technical manual for normal indications.

b. Use an ohmmeter to check for continuity of interconnect cabling between the modular units. (Refer to figure 2-3, sheets 1 through 3).

c. Disconnect the MMX and connect a signal generator to the HFLA-1K input. Operate the HFLA-1K manually into a dummy load (if available) and monitor the HFLA-1K meters for proper operation. (Refer to tables 3-3 and 3-4 of the HFLA-1K technical manual for normal indications.)