

★

TECHNICAL MANUAL
for
POWER CONTROL PANEL
MODEL DCP-1



THE TECHNICAL MATERIEL CORPORATION
MAMARONECK, N. Y. OTTAWA, CANADA

COPYRIGHT 1968
THE TECHNICAL MATERIEL CORPORATION

NOTICE

THE CONTENTS AND INFORMATION CONTAINED IN THIS INSTRUCTION MANUAL IS PROPRIETARY TO THE TECHNICAL MATERIEL CORPORATION TO BE USED AS A GUIDE TO THE OPERATION AND MAINTENANCE OF THE EQUIPMENT FOR WHICH THE MANUAL IS ISSUED AND MAY NOT BE DUPLICATED EITHER IN WHOLE OR IN PART BY ANY MEANS WHATSOEVER WITHOUT THE WRITTEN CONSENT OF THE TECHNICAL MATERIEL CORPORATION.

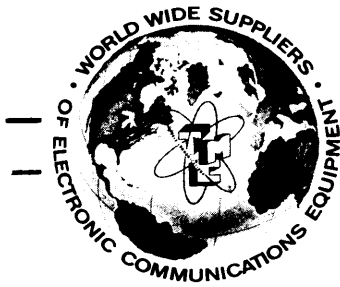

THE TECHNICAL MATERIEL CORPORATION

C O M M U N I C A T I O N S E N G I N E E R S

700 FENIMORE ROAD

MAMARONECK, N. Y.

W a r r a n t y

The Technical Materiel Corporation, hereinafter referred to as TMC, warrants the equipment (except electron tubes,* fuses, lamps, batteries and articles made of glass or other fragile or other expendable materials) purchased hereunder to be free from defect in materials and workmanship under normal use and service, when used for the purposes for which the same is designed, for a period of one year from the date of delivery F.O.B. factory. TMC further warrants that the equipment will perform in a manner equal to or better than published technical specifications as amended by any additions or corrections thereto accompanying the formal equipment offer.

TMC will replace or repair any such defective items, F.O.B. factory, which may fail within the stated warranty period, PROVIDED:

1. That any claim of defect under this warranty is made within sixty (60) days after discovery thereof and that inspection by TMC, if required, indicates the validity of such claim to TMC's satisfaction.
2. That the defect is not the result of damage incurred in shipment from or to the factory.
3. That the equipment has not been altered in any way either as to design or use whether by replacement parts not supplied or approved by TMC, or otherwise.
4. That any equipment or accessories furnished but not manufactured by TMC, or not of TMC design shall be subject only to such adjustments as TMC may obtain from the supplier thereof.

Electron tubes* furnished by TMC, but manufactured by others, bear only the warranty given by such other manufacturers. Electron tube warranty claims should be made directly to the manufacturer of such tubes.

TMC's obligation under this warranty is limited to the repair or replacement of defective parts with the exceptions noted above.

At TMC's option any defective part or equipment which fails within the warranty period shall be returned to TMC's factory for inspection, properly packed with shipping charges prepaid. No parts or equipment shall be returned to TMC, unless a return authorization is issued by TMC.

No warranties, express or implied, other than those specifically set forth herein shall be applicable to any equipment manufactured or furnished by TMC and the foregoing warranty shall constitute the Buyers sole right and remedy. In no event does TMC assume any liability for consequential damages, or for loss, damage or expense directly or indirectly arising from the use of TMC Products, or any inability to use them either separately or in combination with other equipment or materials or from any other cause.

*Electron tubes also include semi-conductor devices.

PROCEDURE FOR RETURN OF MATERIAL OR EQUIPMENT

Should it be necessary to return equipment or material for repair or replacement, whether within warranty or otherwise, a return authorization must be obtained from TMC prior to shipment. The request for return authorization should include the following information:

1. Model Number of Equipment.
2. Serial Number of Equipment.
3. TMC Part Number.
4. Nature of defect or cause of failure.
5. The contract or purchase order under which equipment was delivered.

PROCEDURE FOR ORDERING REPLACEMENT PARTS

When ordering replacement parts, the following information must be included in the order as applicable:

1. Quantity Required.
2. TMC Part Number.
3. Equipment in which used by TMC or Military Model Number.
4. Brief Description of the Item.
5. The *Crystal Frequency* if the order includes crystals.

PROCEDURE IN THE EVENT OF DAMAGE INCURRED IN SHIPMENT

TMC's Warranty specifically excludes damage incurred in shipment to or from the factory. In the event equipment is received in damaged condition, the carrier should be notified immediately. Claims for such damage should be filed with the carrier involved and not with TMC.

All correspondence pertaining to Warranty Claims, return, repair, or replacement and all material or equipment returned for repair or replacement, within Warranty or otherwise, should be addressed as follows:

THE TECHNICAL MATERIEL CORPORATION
Engineering Services Department
700 Fenimore Road
Mamaroneck, New York

TABLE OF CONTENTS

<u>Paragraph</u>		<u>Page</u>
<u>SECTION 1 - GENERAL DESCRIPTION</u>		
1-1	Functional Description	1-1
1-2	Physical Description.	1-1
<u>SECTION 2 - INSTALLATION</u>		
2-1	Initial Inspector	2-0
2-2	Mechanical Installation	2-1
2-3	Electrical Installation.	2-1
<u>SECTION 3 - OPERATOR'S SECTION</u>		
3-1	General	3-0
3-2	Operator's Instruction.	3-0
3-3	Operator's Maintenance.	3-0
<u>SECTION 4 - PRINCIPLES OF OPERATION</u>		
4-1	Introduction.	4-1
4-2	Circuit Description.	4-1
<u>SECTION 5 - TROUBLESHOOTING</u>		
5-1	Introduction.	5-0
5-2	Troubleshooting Procedures.	5-0

TABLE OF CONTENTS CON'T

<u>Paragraph</u>		<u>Page</u>
<u>SECTION 6 - MAINTENANCE</u>		
6-1	Introduction.	6-1
6-2	Preventive Maintenance	6-1
6-3	Corrective Maintenance	6-2

SECTION 7 - PARTS LIST

SECTION 8 - SCHEMATIC DIAGRAMS

LIST OF ILLUSTRATIONS

<u>Figure</u>		<u>Page</u>
<u>SECTION 1 - GENERAL DESCRIPTION</u>		
1-1	Power Control Panel, Model DCP-1	1-0
<u>SECTION 2 - INSTALLATION</u>		
2-1	Electrical Installation.	2-1
<u>SECTION 3 - OPERATOR'S SECTION</u>		
3-1	Front and Rear Panel Components.	3-2
<u>SECTION 8 - SCHEMATIC DIAGRAMS</u>		
8-1	Schematic Diagram, Model DCP-1	8-1/8-2

LIST OF TABLES

<u>Table</u>		<u>Page</u>
<u>SECTION 3 - OPERATOR'S SECTION</u>		
3-1	Front and Rear Panel Control Descriptions.	3-1

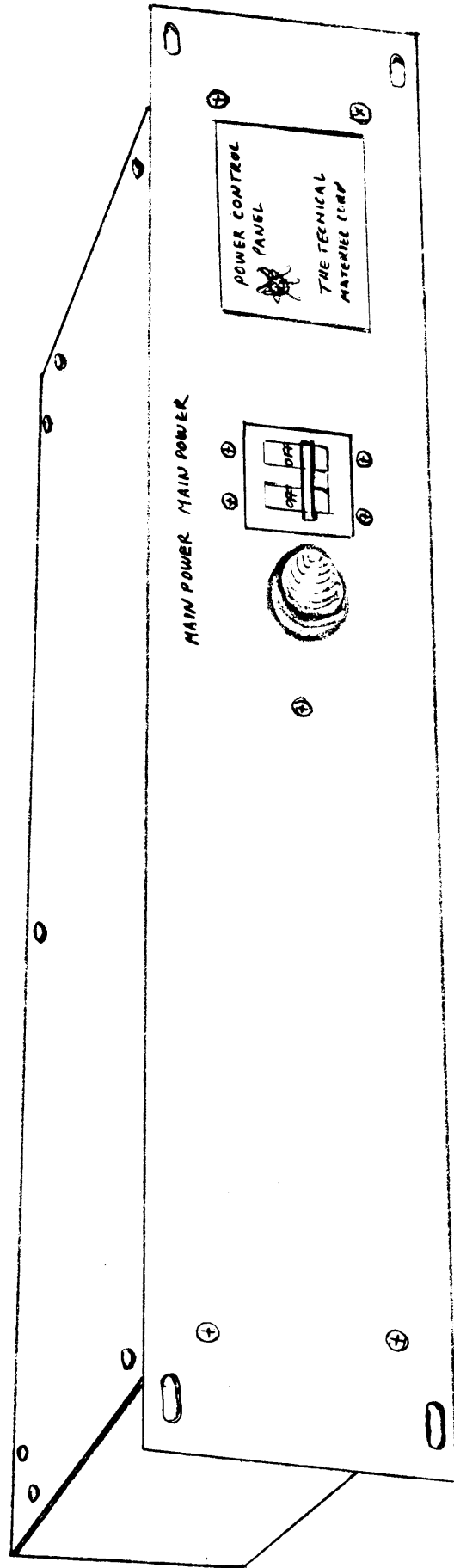

Figure 1-1. Power Control Panel, Model DCP-1

SECTION 1

GENERAL DESCRIPTION

1-1. FUNCTIONAL DESCRIPTION

POWER CONTROL PANEL, MODEL DCP-1 (figure 1-1) is an auxiliary power control panel providing an a-c line input voltage to an a-c output receptacle.

The POWER CONTROL PANEL, MODEL DCP-1 (hereafter referred to as the DCP-1) may be used as a main power control panel for system applications. A front panel mounted main power circuit breaker is provided to control the output a-c line voltage taken from the chassis mounted output terminal board TB2. Uncontrolled a-c output voltage is available at the a-c outlet. A main power indicator lamp is also provided, operating in conjunction with the main power circuit breaker.

1-2. PHYSICAL DESCRIPTION

The DCP-1 is equipped with a 19-inch wide front panel supporting a 7-inch deep chassis. The front panel displays a MAIN POWER circuit breaker and its associated MAIN POWER indicator lamp.

The rear chassis provides an input and an output a-c line voltage cable clamp and a two-prong a-c output receptacle.

SECTION 2

INSTALLATION

2-1. INITIAL INSPECTION

Each DCP-1 has been thoroughly checked and tested at the factory before shipment. Upon arrival at the operating site, inspect the packing case and its contents immediately for possible damage. Unpack the equipment carefully. Inspect all packing material for parts which may have been shipped as loose items.

With respect to damage to the equipment for which the carrier is liable, The Technical Materiel Corporation will assist in describing methods of repair and the furnishing of replacement parts.

2-2. MECHANICAL INSTALLATION

The DCP-1 is equipped with a 19 inch wide front panel, designed to be mounted into any standard width equipment rack or console. The front panel is to be screw fastened to the rack frame.

2-3. ELECTRICAL INSTALLATION

After the DCP-1 has been mounted to the rack frame, remove the top chassis dust cover. Connect a 3-wire a-c power cable to input terminal board TB1. Connect the a-c voltage wires to terminals 1 and 2 of TB1. Connect the third grounding wire to the grounding lug mounted alongside TB1. This a-c cable is to be routed through the chassis mounted cable clamp and connected to an external a-c primary power source.

After the a-c wiring has been completed, set the front panel circuit breaker ON; the MAIN POWER indicator lamp should light. Connect an a-c voltmeter to the AUXILIARY OUTLET and observe for proper a-c output voltage; should be identical to primary a-c input power. See figure 2-1 for electrical installation.

NOTE

Unless otherwise specified, each DCP-1 is factory wired for 115 volts a-c input operation. For 230 volts a-c input operation, remove jumper wire across resistor R1.

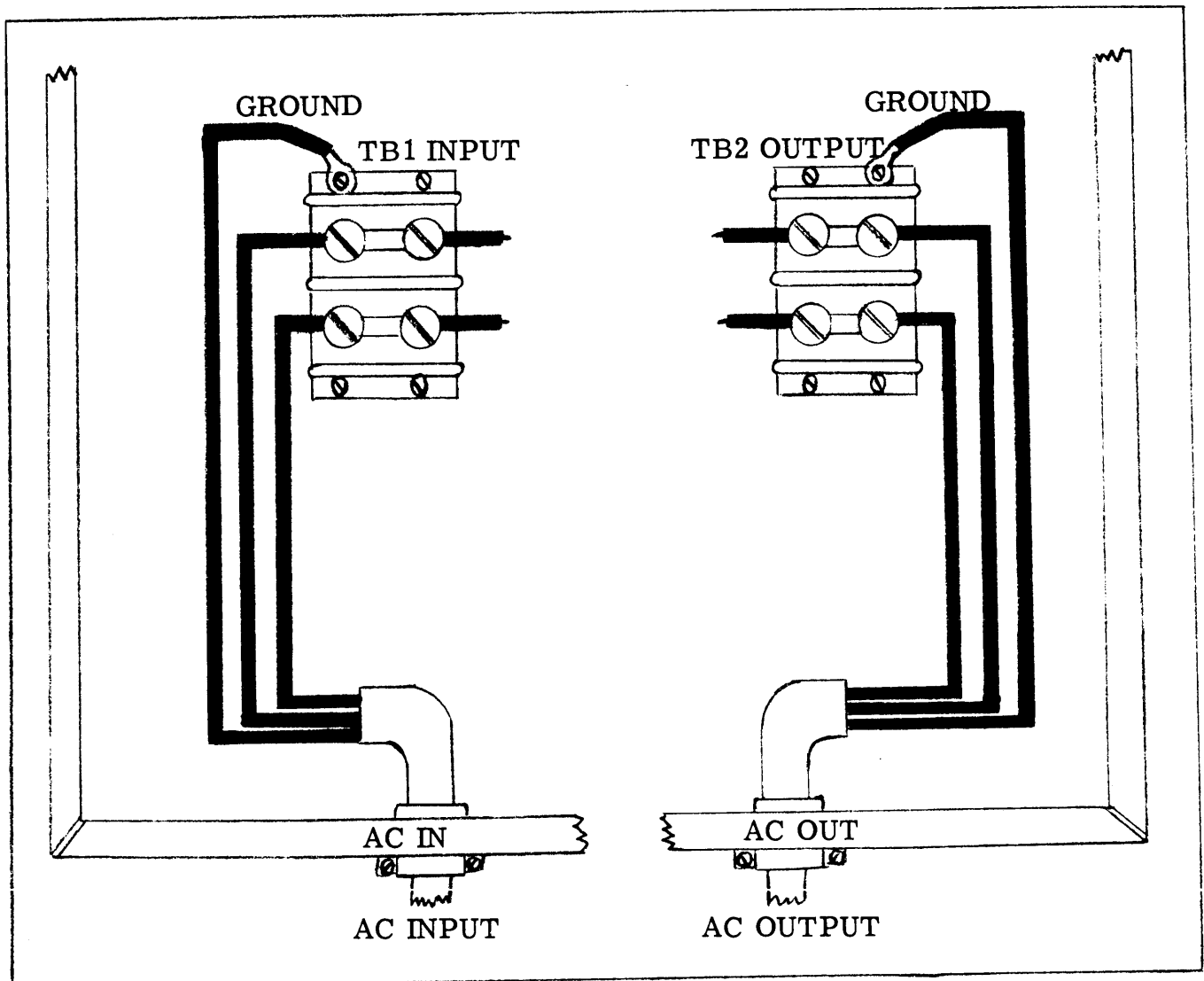

Figure 2-1. Electrical Installation Diagram

SECTION 3
OPERATOR'S SECTION

3-1. GENERAL

The DCP-1 is designed to provide auxiliary a-c power outlets for external test equipment use. Permanently installed equipment requiring externally controlled a-c line voltage may be connected to the rear chassis mounted output terminal board TB2.

3-2. OPERATOR'S INSTRUCTIONS

Due to the simplicity in construction and design of the DCP-1, the operator's requirements are kept to a minimum. These requirements consist of mainly observing that the MAIN POWER indicator light when MAIN POWER circuit breaker in ON. Extinguishing of the MAIN POWER indicator lamp signifies loss of a-c input power if the MAIN POWER circuit breaker is still in the ON position. An overload in a-c current drain (above 10 amperes) will trip the circuit breaker setting it to OFF; indicator should extinguish.

3-3. OPERATOR'S MAINTENANCE

Operator's maintenance will consist mainly of keeping the unit clean, observing for proper securing of input and output a-c voltage connections.

TABLE 3-1. FRONT AND REAR PANEL CONTROL DESCRIPTION

REF. DESIG. (Fig. 3-1)	PANEL DESIGNATION	DESCRIPTION	FUNCTION
1	MAIN POWER	Incandescent lamp, DS1	Power indicator lamp operating in conjunction with MAIN POWER circuit breaker; lights when power is applied with MAIN POWER circuit breaker in ON position.
2	MAIN POWER	Dual toggle switch type circuit breaker, CB1.	A-c input line protection Trips when 10 ampere rating is exceeded.
3	AC INPUT	Input a-c cable clamp.	Provides access hole and cable clamping for a-c input cable.
4	J1	2-prong polarized a-c output connector.	Provides a-c output for any permanently installed equipment a-c line voltage.
5	AC OUTPUT	Output a-c cable clamp.	Provides access hole and cable clamping for a-c output cable.

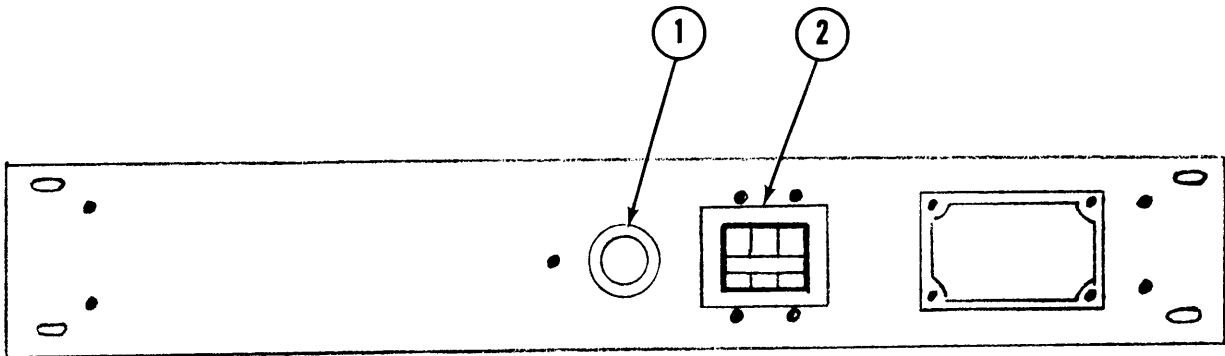

FRONT VIEW

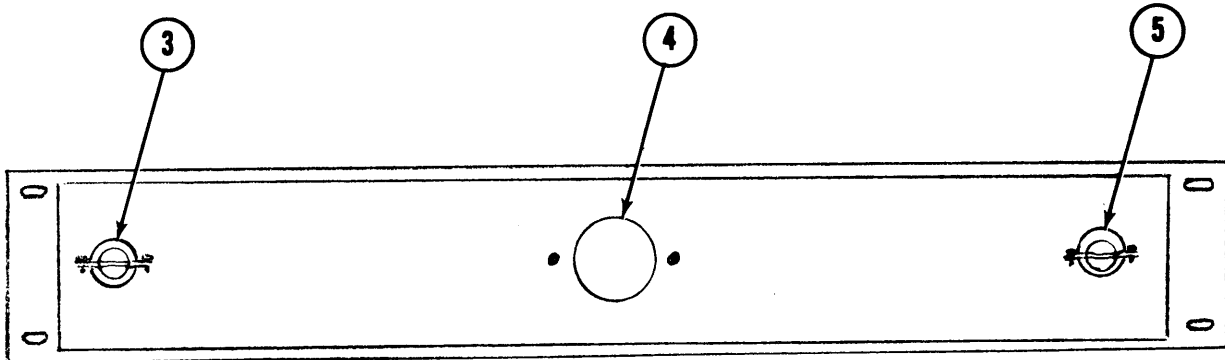

REAR VIEW

Figure 3-1. Front and Rear Panel Components.

SECTION 4

PRINCIPLES OF OPERATION

4-1. INTRODUCTION

The DCP-1 is designed to operate as an auxiliary power outlet panel and as a main power control panel. Any equipment receiving primary a-c power via the output terminal board TB2, will be controlled by the front panel MAIN POWER circuit breaker. Voltage at the outlet however, is not controlled by the circuit breaker.

4-2. CIRCUIT DESCRIPTION

Input a-c line voltage is applied to input terminal board TB1, terminals 1 and 2. The a-c line voltage is then distributed to the a-c two-prong outlet. Voltage at the output terminal board TB2 is applied through and controlled by MAIN POWER circuit breaker CB1. MAIN POWER indicator lamp DS1 is used to indicate presence of a-c line voltage at output terminal board TB2. The MAIN POWER circuit breaker CB1 is rated at 10 amperes, any increase in current will automatically trip the circuit breaker, setting it to OFF.

SECTION 5
TROUBLESHOOTING

5-1. INTRODUCTION

Due to the simplicity in construction and operation of the DCP-1, unit troubleshooting is relatively simple. The following text will provide various troubleshooting techniques which may be varied or enhanced by the technicians own troubleshooting techniques.

5-2. TROUBLESHOOTING PROCEDURES

The following troubleshooting procedures are to be performed assuming that the fault is localized to the DCP-1 and that primary a-c power is available.

- a. Check for proper a-c input cable connection to terminal board TB1, terminals 1 and 2.
- b. Check for proper a-c output cable connection to terminal board TB2, terminals 1 and 2.
- c. Visually and by means of continuity testing, check condition and connection of unit wiring using the schematic diagram provided in Section 8.
- d. If circuit breaker CB1 keeps tripping (switching to OFF) check for possible short in associated circuitry. Circuit breaker CB1 will automatically trip when an excess of 10 amperes is drawn. Check associated equipment being supplied from the DCP-1 for possible short or other excess current drawing causes.

SECTION 6

MAINTENANCE

6-1. INTRODUCTION

Maintenance may be divided into three categories: operator's maintenance, preventive maintenance and corrective maintenance.

The operator may, at certain times, be required to perform various aspects of operator's maintenance. This type of maintenance may consist of simply keeping the unit clean and observing for tight interconnecting cable connections. However, should normal operating procedures produce unsatisfactory results, a check of the interconnections and a-c input voltage levels to the DCP-1 may clear the fault.

The corrective maintenance procedures provide information useful in locating and diagnosing equipment troubles and maladjustments.

The DCP-1 has been designed to provide long-term, troublefree operation under normal duty conditions.

6-2. PREVENTIVE MAINTENANCE

a. In order to prevent equipment failure due to dust, dirt and other destructive elements, it is suggested that a schedule of preventive maintenance be set up and adhered to.

b. At periodic intervals, the equipment should be removed from its mounting for cleaning and inspection. All accessible covers should be removed and the wiring and all components inspected for dirt, corrosion, charring, discoloring or grease. Remove dust with a soft brush or vacuum cleaner. Remove dirt or grease from other parts with any suitable cleaning solvent.

Use of carbon tetrachloride should be avoided due to its highly toxic effects. Trichlorethylene or methyl chloroform may be used, providing the necessary precautions are observed.

WARNING

When using toxic solvents, make certain that adequate ventilation exist. Avoid prolonged or repeated contact with skin. Flammable solvents shall not be used on energized equipment or near any equipment from which a spark may be received. Smoking "hot work", etc. is prohibited in the immediate area.

CAUTION

When using trichlorethylene, avoid contact with painted surfaces, due to its pain removing effects.

6-3. CORRECTIVE MAINTENANCE

Corrective maintenance of the DCP-1 will consist mainly of component replacement. It should be noted that when replacing components, the technician should observe for exact or equivalent replacements by referring to the parts list in section 7. Polarity and positioning of certain components should be observed before removing so that the replacement component will fit and operate correctly.

SECTION 7
PARTS LIST

POWER CONTROL PANEL DCP1

REF SYMBOL	DESCRIPTION	TMC PART NUMBER
CB1	CIRCUIT BREAKER: double pole; 10 amps, 110/230 VAC.	SW251
DS1	LAMP, INCANDESCENT: 120 volts, 3 watts; S6 clear bulb; double contact, bayonet base.	BI102-2
J1	CONNECTOR, RECEPTACLE, ELECTRICAL: 2 prong female; polarized; 125 V, 15 amps; 250 V, 10 amps.	JJ130
R1	RESISTOR, FIXED, WIREWOUND: 2,500 ohms, <u>+5%</u> ; 25 watts.	RW111-25
TB1	TERMINAL BOARD: barrier type; 4 #10-32 binder head double screw terminals; phenolic black bakelite body.	TM118-2
TB2	Same as TB1.	
XDS1	SOCKET, LAMP: for bayonet base, double contact S6 bulb; screw type terminals, red lens.	TS114-11

SECTION 8
SCHEMATIC DIAGRAMS

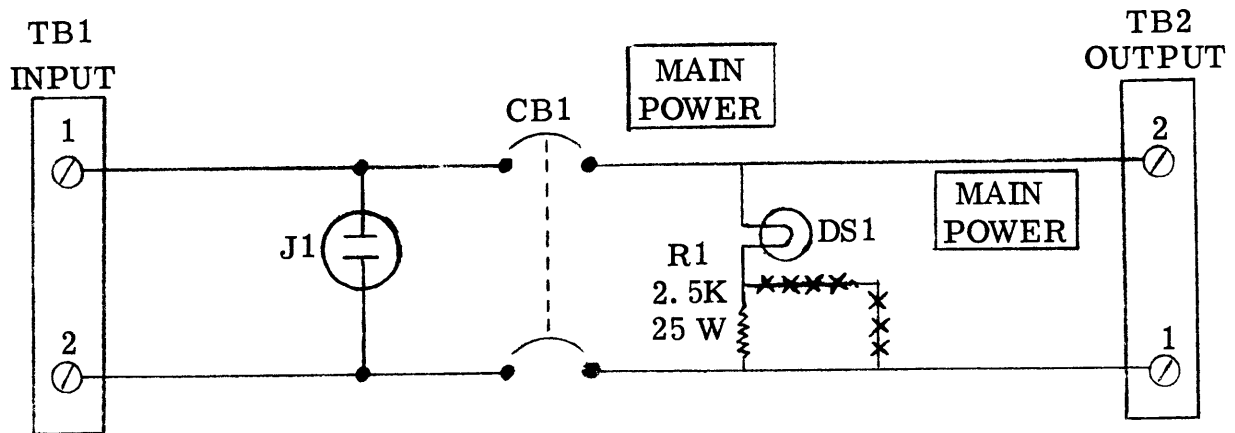

NOTE: FOR 230 VAC OPERATION,
 REMOVE JUMPER WIRE
 MARKED ****

Figure 8-1. Schematic Diagram, Model DCP-1