

Remove Bushing Ass'y Before  
Assembling To Chassis.

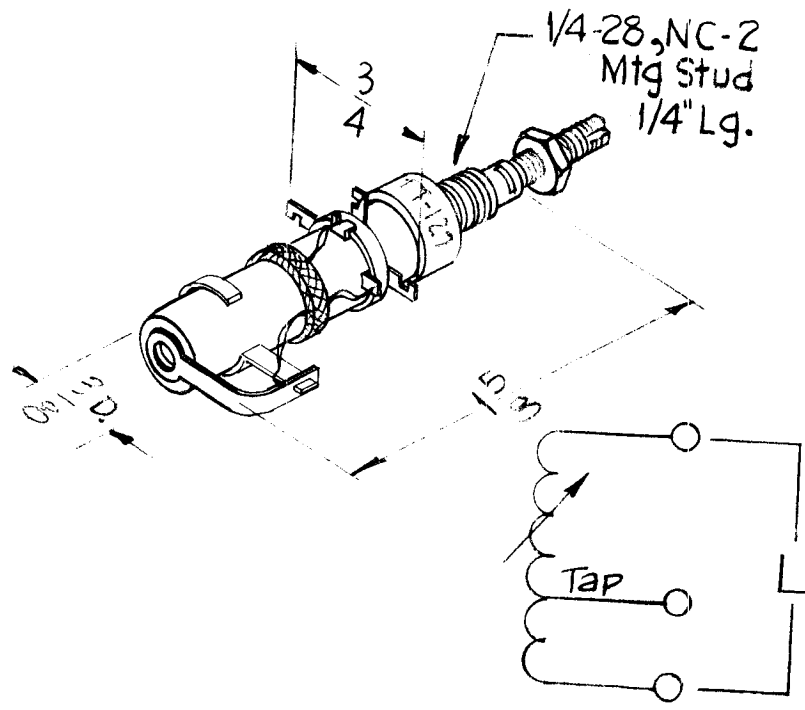

REQ. PER UNIT	USED ON		
	MODEL	ASS'Y. NO.	SYMBOL
2	CHG-1	MF/RF	TT112, TT118

TT-127

ELECTRICAL SPECIFICATIONS  
 L -  $28 \pm 3$  Micronhenries (w/o Core)  
 Q - 60 or Greater  
 FREQ (TEST) - 2.5 MC.  
 OPER. FREQ. - 1.75 - 3.75 MC.

MECHANICAL SPECIFICATIONS  
 TOTAL TURNS - 44  
 TAP - 17 TURNS  
 TUNING SLOTS - POWDERED IRON  
 FORM-PHENOLIC

ISSUE ITEM		CHANGED FROM		DATE	CH. NO.	DRAFTS	CHECKER	ENG. APP.	REQ. ITEM	PART NO.	DESCRIPTION	SYMBOL	
TOLERANCES		SCALE:		2A-2041					MATERIAL		ANGER		
DEC. DIM. $\pm$		MAXIMUM ALLOWABLE TOLERANCES HAVE BEEN DETERMINED AND ANY DEVIATIONS WILL BE CAUSE FOR REJECTION. REMOVE ALL BURRS AND SHARP EDGES							TYPE & TEMPER		HEATTREAT. SPEC.		
FRAC. DIM. $\pm$									FINISH & SPEC. NO.		ELEC. DES. APP		MECH. DES. APP
ANGULAR DIM. $\pm$									DRAWN		CHECKED		FINAL APPROVAL
									12-15-60		TT-127		