

|               |         |            |         |       |   |
|---------------|---------|------------|---------|-------|---|
| REQ. PER UNIT | USED ON |            |         | PX956 | Ø |
|               | MODEL   | ASS'Y. NO. | DATE    |       |   |
| 1             | AF105   | A5388      | 7-20-65 |       |   |

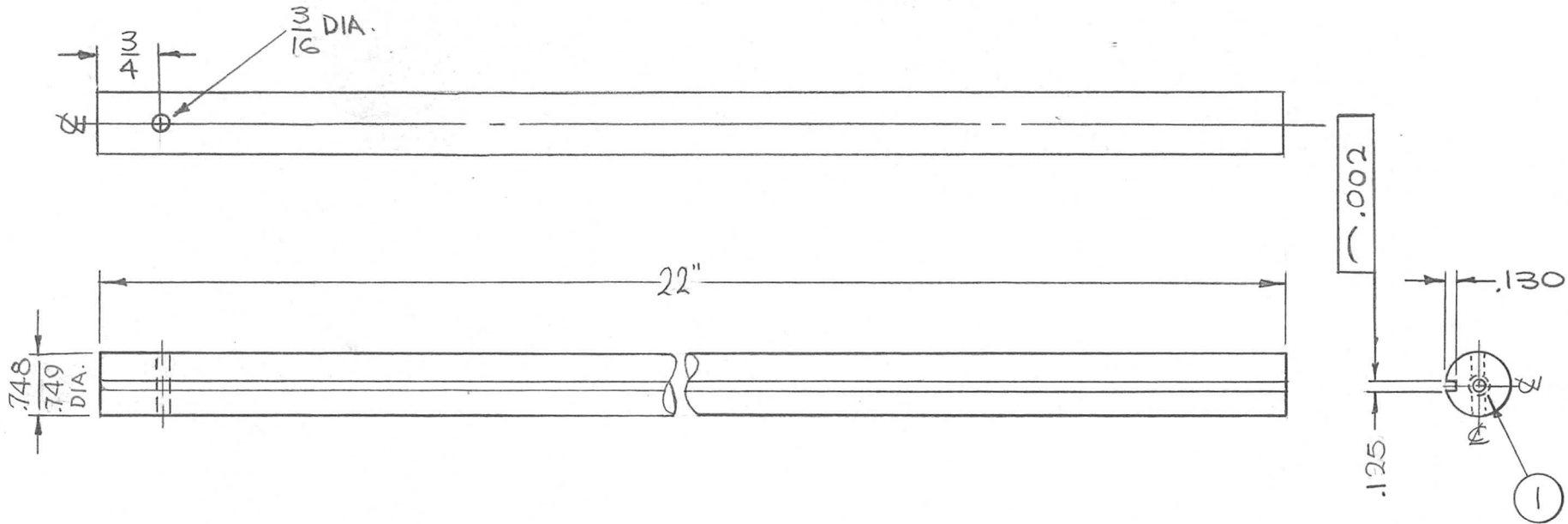

|   |                                       |         |         |        |         |                                  |               |                    |  |                        |                 |                |
|---|---------------------------------------|---------|---------|--------|---------|----------------------------------|---------------|--------------------|--|------------------------|-----------------|----------------|
| Ø   | ORIGINAL RELEASE FOR PRODUCTION       | 4-29-66 | Ø       | WFW    |         | File                             | 1             | 1                  | NT139-SFI-20   | INSERT, SCREW, THREAD  |                 |                |
| X3  | ITEM 1 WAS NT139-SCC-20               | 4-7-66  | X3      | B-DL   |         |                                  | REQ.          | ITEM               | PART NO.   | F. BUDETTI DESCRIPTION | SYMBOL          |                |
| X2  | 22 WAS 24, 3/16 HOLE ADDED            |         |         |        |         |                                  | AS NOTED      |                    | THE TECHNICAL MATERIEL CORP.<br>MAMARONECK, NEW YORK |                        |                 |                |
| X1  | SLOT ADDED, 24" WAS 25" ITEM 1 ADDED. | 7-20-65 | X1      | RPH    |         |                                  | EPOXY-G11     |                    | SHAFT, LOW PASS FILTER, SWITCHING                    |                        |                 |                |
| SYM   | DESCRIPTION                           | DATE    | CH. NO. | DRAFTS | CHECKER | ENG. APP.                        | MATERIAL      |                    |  |                        |                 |                |
| UNLESS OTHERWISE SPECIFIED DIMENSIONS ARE IN INCHES AND INCLUDE CHEMICALLY APPLIED OR PLATED FINISHES |                                       |         |         |        |         | SCALE                            |               |                    |  |                        |                 |                |
|   |                                       |         |         |        |         | 1/2:1                            | TYPE & TEMPER |                    | HEAT TREAT. SPEC.                                    | DRAWN                  | CHECKED         | FINAL APPROVAL |
| DECIMALS .X ± .05 .XX ± .01 .XXX ± .005   |                                       |         |         |        |         | FRACTIONS ± 1/64 ANGLES ± 0° 30' | CODE          | FINISH & SPEC. NO. |  | ELEC. DES. APP.        | MECH. DES. APP. | PX956 Ø        |
|   |                                       |         |         |        |         | A                                |               |                    |  |                        |                 |                |