

REQ. PER UNIT	USED ON			PX 948	Ø
	MODEL	ASS'Y. NO.	DATE		
4 EA	TST-10K		6-3-65		

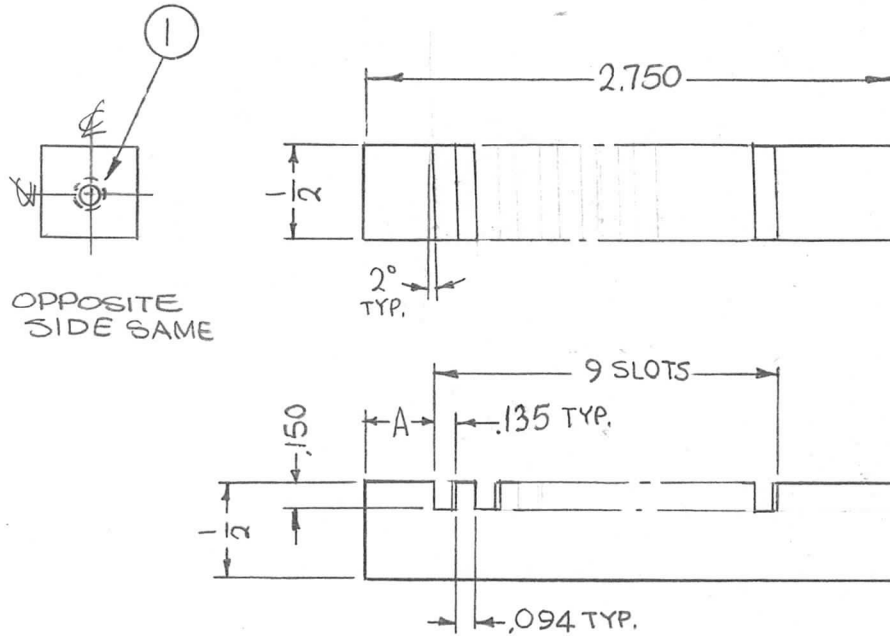

TMC P/N	A
PX 948-1	.365
PX 948-2	.435
PX 948-3	.505

							2	1	NT139SG06-20	INSERT, SCREW THREAD			
							REQ. ITEM	PART NO.		F. BUDETTI DESCRIPTION	SYMBOL		
							SEE DWG			THE TECHNICAL MATERIEL CORP. MAMARONECK, NEW YORK			
							STOCK SIZE			SPACER, COIL			
							G11 - EPOXY						
							MATERIAL						
							TYPE & TEMPER			DRAWN			
							HEAT TREAT. SPEC.			CHECKED			
							FINISH & SPEC. NO.			ELEC. DES. APP.			
										MECH. DES. APP.			
										PX 948 Ø			
UNLESS OTHERWISE SPECIFIED DIMENSIONS ARE IN INCHES AND INCLUDE CHEMICALLY APPLIED OR PLATED FINISHES		SCALE											
		1:1											
DECIMALS	TOLERANCES		FRACTIONS	CODE									
.X ± .05			± 1/64	A									
.XX ± .01			ANGLES										
.XXX ± .005			± 0° 30'										
Ø	ORIGINAL RELEASE FOR PRODUCTION	3-3-66	AA	Jc	JP arc								
X1	435 WAS 420, 505 WAS 450 .135 WAS .129, 365 WAS 390	6-10-65	X1	JP	JP								
SYM	DESCRIPTION	DATE	CH. NO.	DRAFTS	CHECKER	ENG. APP.							