

PX-737

REVISIONS					
SYM	DESCRIPTION	DATE	E.M.N. NO.	DRAFT	CHKD APPD
0	ORIGINAL RELEASE FOR PRODUCTION	5-13-64	0	A.M.	

HOLES:

- A ~ 1-DRILL 13/64 (.203) TO .552 MIN. DEPTH.
- 2-120° C' SINK .22-.25 DIA.
- 3-TAP, 410 MIN. DEPTH USE HELI-COIL TAP NO. 3FPB
- 4-INSTALL ITEM ① 3/4 TO 1-1/2 PITCH BELOW SURFACE
- 5-BREAK OFF DRIVING TANG.

B ~ SEE DETAIL.

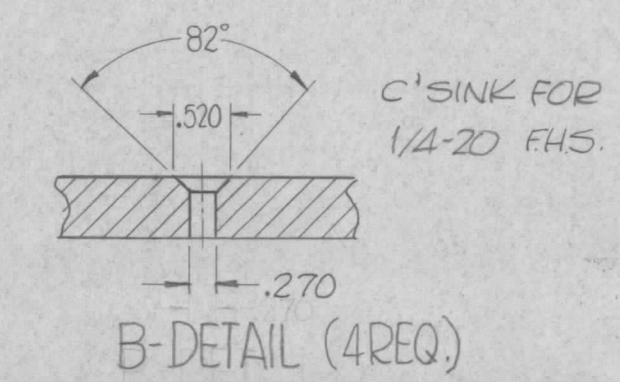

REQ'D.	ITEM	PART NUMBER	DESCRIPTION	SYMBOL
4	1	NT-139-SF-1-20	HELI-COIL	

F. BUDETTI LIST OF MATERIAL

MATERIAL	THE TECHNICAL MATERIEL CORP. MAMARONECK, NEW YORK		
G-7 SILICONE GLASS			
FINISH	TITLE		
	SUPPORT, FILAMENT COIL		

UNLESS OTHERWISE SPECIFIED DIMENSIONS ARE IN INCHES AND INCLUDE CHEMICALLY APPLIED OR PLATED FINISHES	DRAWN	DATE	FINAL APPROVAL	DATE
	SRG	3-13-63		
	CHECKED	DATE		
	aa			
DECIMALS	ELECT. DES.	DATE	PX-737	O
.X ± .05	20	5/16/64		
.XX ± .01				
.XXX ± .005	MECH. DES.	DATE	SHEET	REV. LTR.
		2/15/64		

NOTES

THE CONTENTS OF THIS DRAWING ARE THE EXCLUSIVE PROPERTY OF THE TECHNICAL MATERIEL CORP. ITS UNAUTHORIZED USE OR REPRODUCTION IN WHOLE OR IN PART IS STRICTLY FORBIDDEN.