

REQ. PER. UNIT	USED ON			PX-599
	MODEL	ASSY. NO.	DATE	
1	CHG-1		11-21-60	

6-32 TAP x 3/8 DEEP ON 5/8 RADIUS
3 REQ.

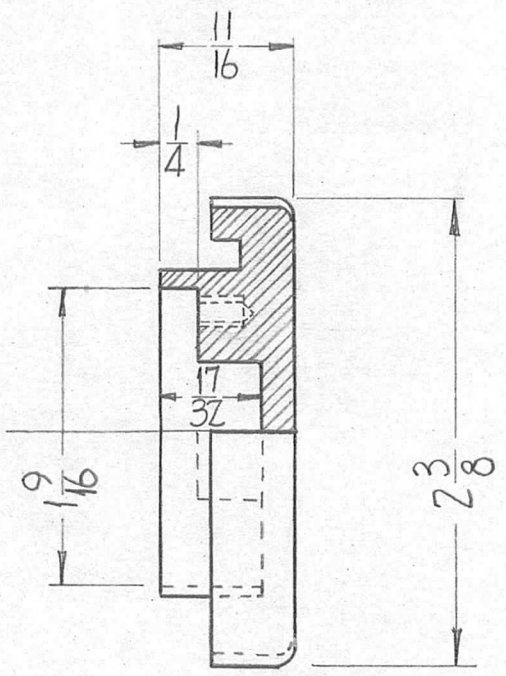
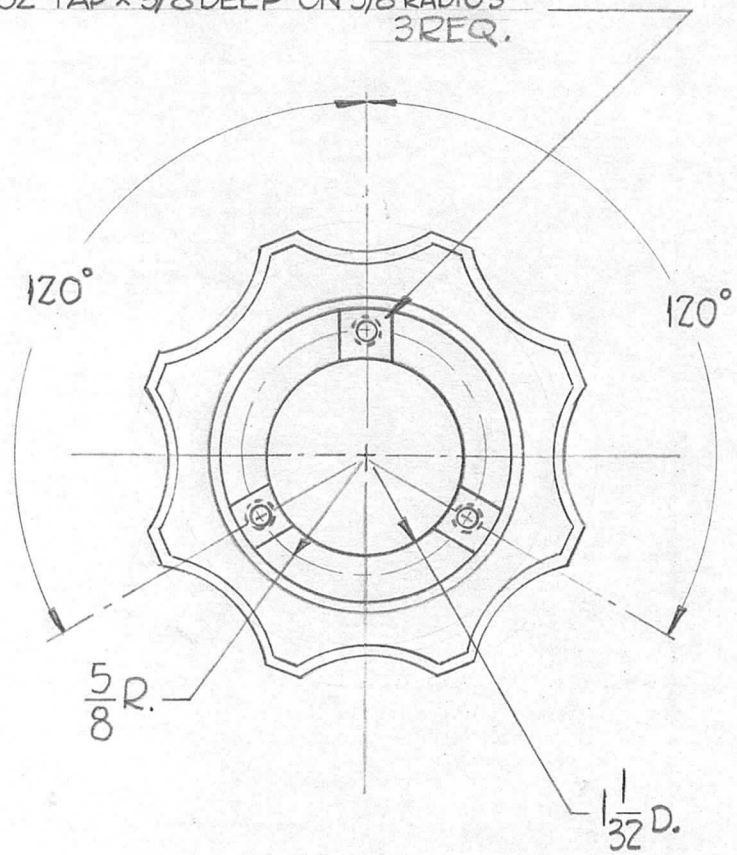

REF. MP-110 (MODIFIED AS SHOWN)

								REQ. ITEM	PART NO.	DESCRIPTION		SYMBOL	
										THE TECHNICAL MATERIEL CORP.			
										MAMARONECK, NEW YORK			
										KNOB, MODIFICATION			
ISSUE	ITEM	CHANGED FROM	DATE	CH. NO.	DRAFTS	CHECKER	ENG. APP.	MATERIAL					
TOLERANCES			SCALE:							 DRAWN	 CHECKED	 FINAL APPROVAL	
DEC. DIM. ±			MAXIMUM ALLOWABLE TOLERANCES HAVE BEEN DETERMINED AND ANY DEVIATIONS WILL BE CAUSE FOR REJECTION. REMOVE ALL BURRS AND SHARP EDGES					TYPE & TEMPER	HEAT TREAT. SPEC.			PX-599	
FRAC. DIM. ±								FINISH & SPEC. NO.	ELEC. DES. APP	MECH. DES. APP			
ANGULAR DIM. ±													