

APPLICATION			REVISIONS						
QTY	MODEL USED ON	ASS'Y NO.	LTR	DESCRIPTION	DATE	E.M.N.NO	DRAFT	CHKD	APPD
2	TLAA-1K	AX5132	Ø	ORIGINAL RELEASE	4/4/73		Ø		

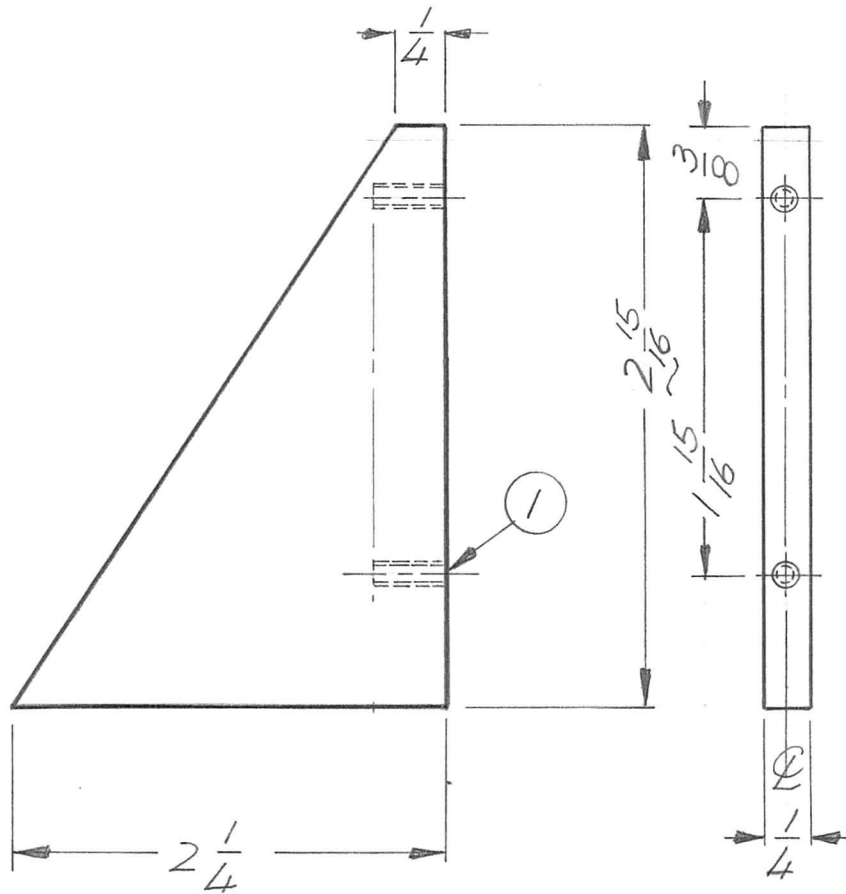

REQ'D	ITEM	PART NUMBER	DESCRIPTION	SYM.
2	1	NT1395C06-15	INSERT SCREW THREAD	

UNLESS OTHERWISE SPECIFIED DIMENSIONS ARE IN INCHES AND INCLUDE CHEMICALLY APPLIED OR PLATED FINISHES		LIST OF MATERIAL	
DECIMALS .X ± .05 .XX ± .01 .XXX ± .005	FRACTIONS 1/64 ANGLES 0°-30'	FINAL APPROVAL <i>F.B.</i>	DATE 20 MAR 73
MATERIAL 1/4 THK G11 EPOXY		MECH. DES. <i>JM</i>	DATE 29 MAR 73
FINISH		ELECT. DES.	DATE
		CHECKED	DATE
		DRAWN <i>CE</i>	DATE 8/2/72
		THE TECHNICAL MATERIEL CORP. MAMARONECK, NEW YORK	
		SUPPORT, PLATE	

NOTICE TO PERSONS RECEIVING THIS DRAWING THE TECHNICAL MATERIEL CORPORATION claims proprietary right in the material disclosed hereon. This drawing is issued in confidence for engineering information only and may not be reproduced or used to manufacture anything shown hereon without permission from THE TECHNICAL MATERIEL CORPORATION to the user. This drawing is loaned for mutual assistance and is subject to recall at any time.	SIZE A	CODE IDENT. NO. 82679	DWG NO. PX1180	ISSUE Ø
	SCALE 1:1		SHEET	OF