

HOLES	REQ
A - 3/8 DIA. (RELIEF HOLE)	1
B - DRILL & TAP 1/4-20 X 5/8 DEEP	1
C - DRILL & TAP 1/4-20 THRU	2

PM-856

REVISIONS						
SYM	DESCRIPTION	DATE	E.M.N. NO.	DRAFT	CHKD	APPD
0	ORIGINAL RELEASE FOR PRODUCTION	3-6-64				

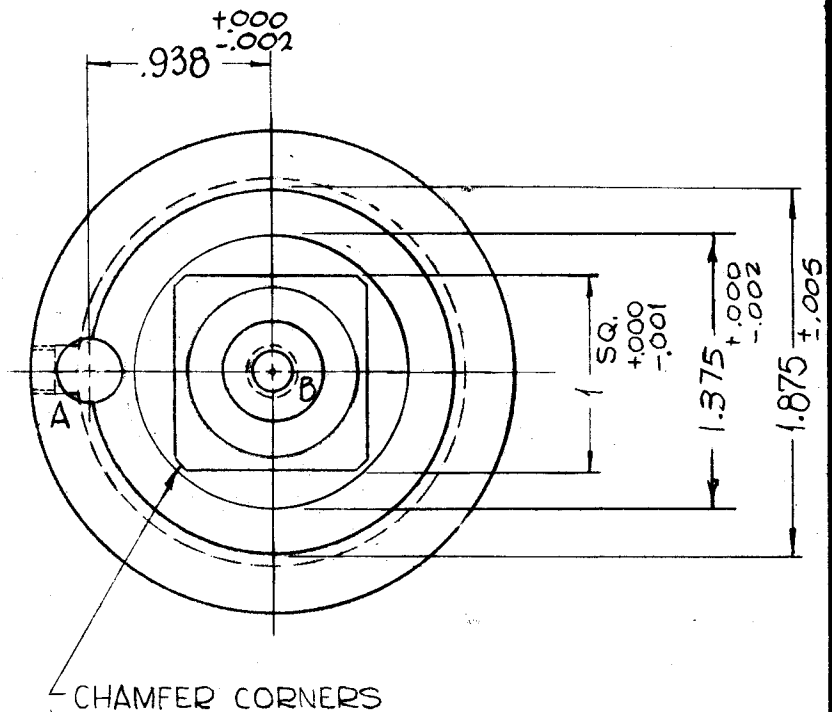
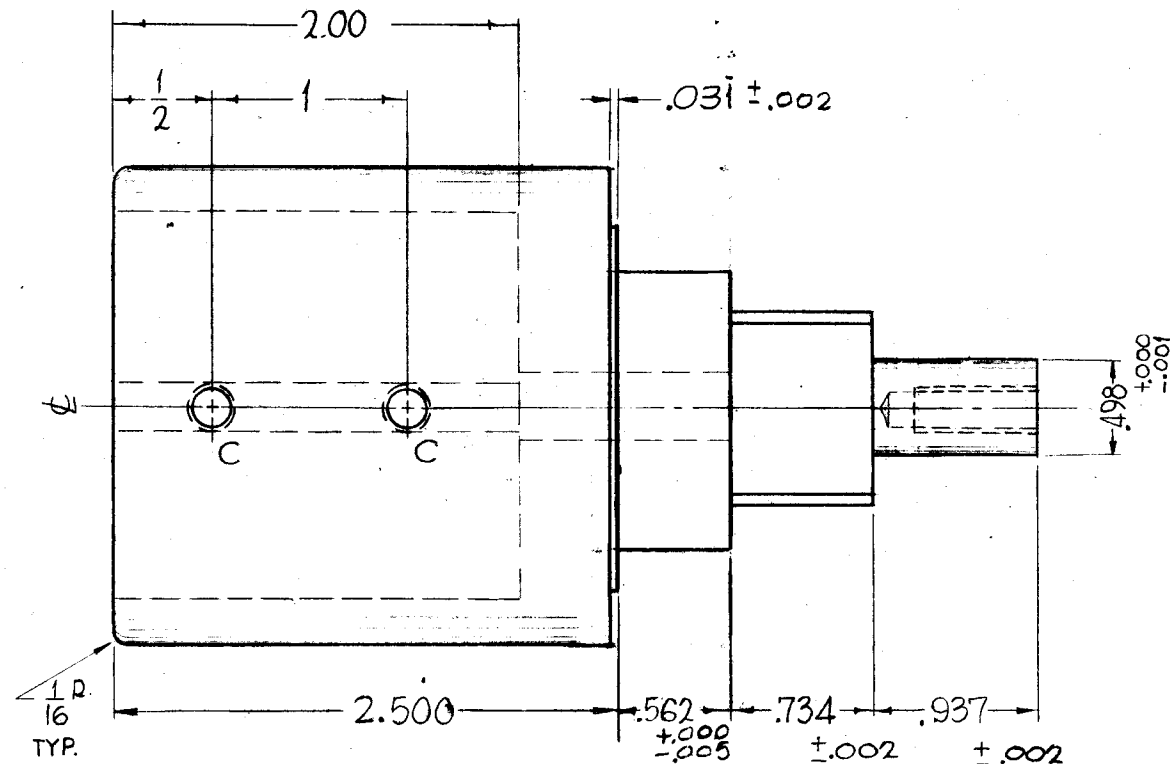
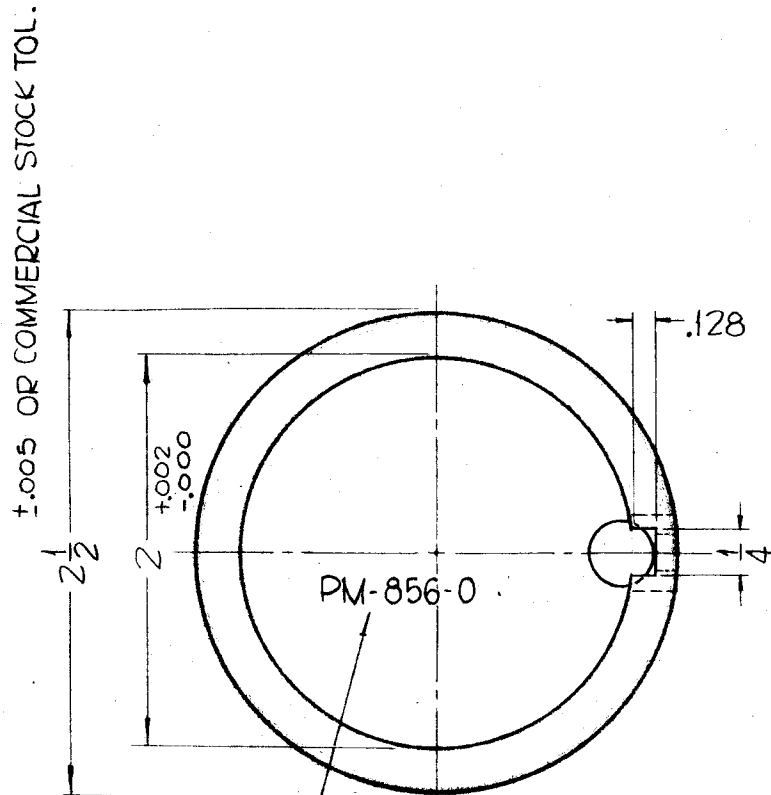

METAL STAMP TMC PART NO. 1/8 HIGH GOTHIC.

1	GPT-200K (AS-123)	A-2681
QTY./UNIT	MODEL USED ON	ASSY. NO.
SCALE DO NOT SCALE	CODE A	
THE CONTENTS OF THIS DRAWING ARE THE EXCLUSIVE PROPERTY OF THE TECHNICAL MATERIEL CORP. ITS UNAUTHORIZED USE OR REPRODUCTION IN WHOLE OR IN PART IS STRICTLY FORBIDDEN.		

REQ'D.	ITEM	PART NUMBER	DESCRIPTION	SYMBOL
F. BUDETTI LIST OF MATERIAL				
MATERIAL STAINLESS STEEL, 303			THE TECHNICAL MATERIEL CORP. MAMARONECK, NEW YORK	
FINISH S-104-PASSIVATE			TITLE —HUB, BANDSWITCH—	
UNLESS OTHERWISE SPECIFIED DIMENSIONS ARE IN INCHES AND INCLUDE CHEMICALLY APPLIED OR PLATED FINISHES			DRAWN Granfilippo	DATE 1-5-62
			CHECKED [Signature]	DATE 3-6-64
			ELECT. DES. [Signature]	DATE 3/6/64
			MECH. DES. [Signature]	DATE
DECIMALS .X ± .05 .XX ± .01 .XXX ± .005			TOLERANCES FRACTIONS ± 1/64 ANGLES ± 0° 30'	
			FINAL APPROVAL [Signature]	
			DATE 4-7-64	
			SHEET PM-856	
			REV. LTR. 0	

NOTES