

REQ. PER UNIT	USED ON			PM-632	B
	MODEL	ASS'Y. NO.	DATE		
1	GPT-40K	AX-209	3-14-60		

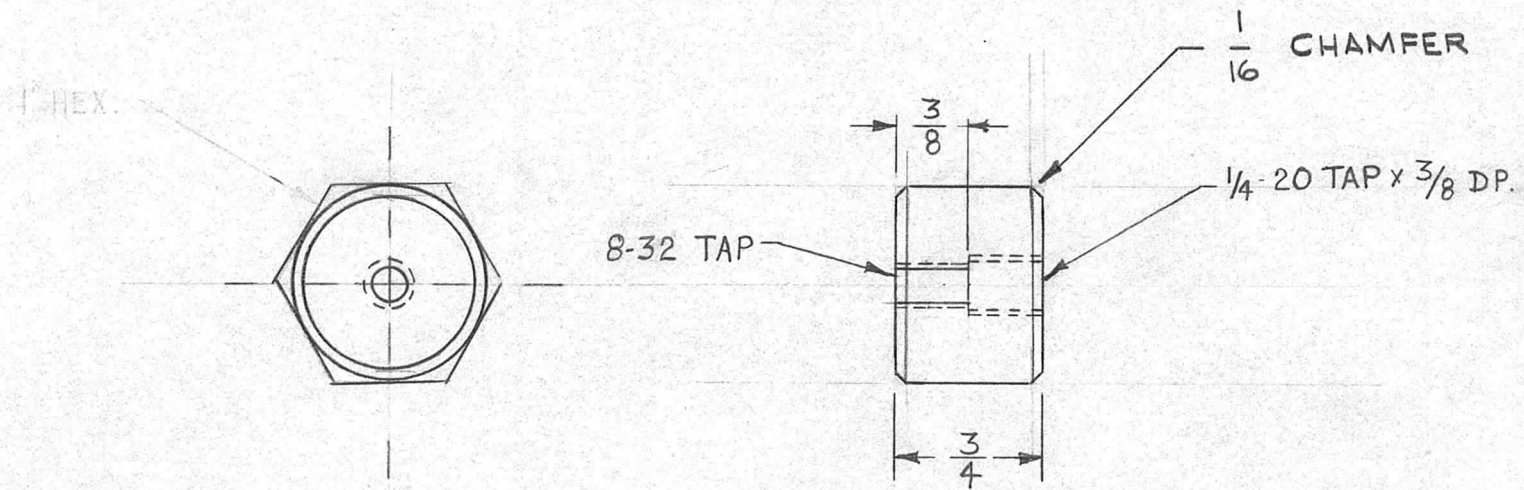

JUN 20 1960

ISSUE	ITEM	CHANGED FROM	DATE	CH. NO.	DRAFTS	CHECKER	ENG. APP.	REQ. ITEM	PART NO.	DESCRIPTION	SYMBOL	
								1" HEX ROD	THE TECHNICAL MATERIEL CORP.			
B	1	QUAN PER UNIT WAS 2	10/11/60	3061	BBB	WJ	WJ	STOCK SIZE	MAMARONECK, NEW YORK			
A	1	ADDED 1/16 CHAMFER	7-18/60	2588	P	WJ	WJ	BRASS	NUT, CONNECTING, TOR			
								MATERIAL	60 COIL TO CAPACITOR			
								FREE TURNING	WJ	WJ	WJ	
TOLERANCES			SCALE:					TYPE & TEMPER	HEAT TREAT. SPEC.	DRAWN	CHECKED	FINAL APPROVAL
DEC. DIM. ± FRAC. DIM. ± 1/64 ANGULAR DIM. ±			MAXIMUM ALLOWABLE TOLERANCES HAVE BEEN DETERMINED AND ANY DEVIATIONS WILL BE CAUSE FOR REJECTION. REMOVE ALL BURRS AND SHARP EDGES					GOLD PLATE .000025			WJ	WJ
								FINISH & SPEC. NO.	ELEC. DES. APP	MECH. DES. APP	PM-632	B