

REQ. PER UNIT	USED ON		
	MODEL	ASS'Y. NO.	DATE
3	GPT-40K	AS-125	1-23-60
3	GPT-200K	AS-124	5-12-64

PM-590

D

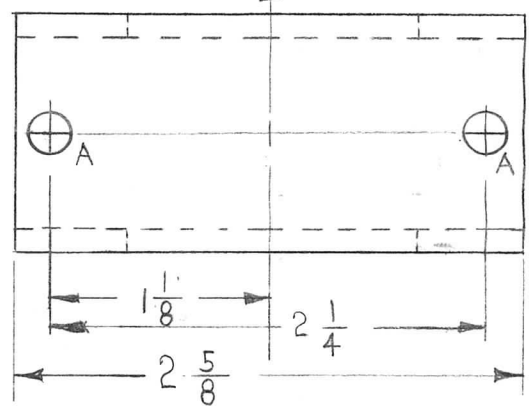
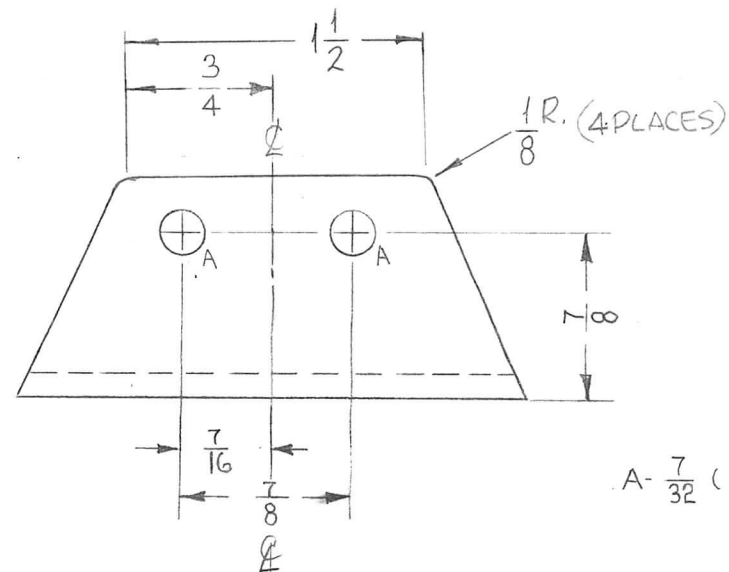
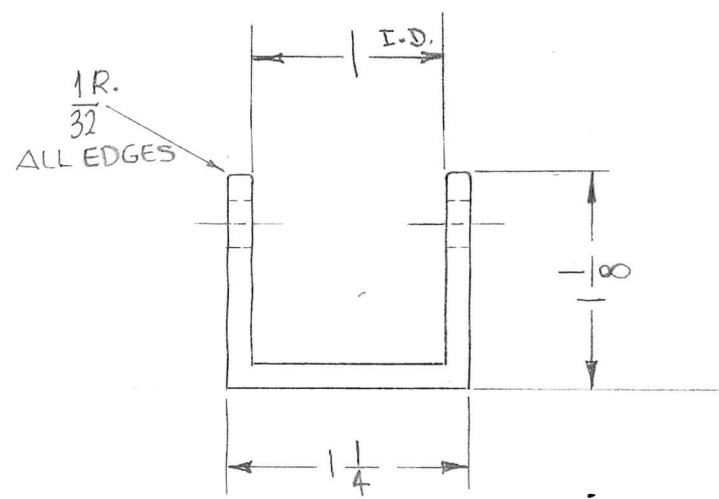

ISSUE	ITEM	CHANGED FROM	DATE	CH. NO.	DRAFTS	CHECKER	ENG. APP.	REQ. ITEM	PART NO.	DESCRIPTION	SYMBOL	
D	1	CLERICAL CHANGE	9.1.64	+	WB	J.P.						
C	~	1-1/8 WAS 1/4, 1/32 & 1/8 R ADDED AX 125 WAS AX 209, AS-124 ADDED	7-29-64	11971	SRG	JCB						
B	2	2 1/4 D WAS 2 1/8	3-21-60	~	MF	W.D.	16					
A	1	1/8 D. WAS 1/16	2/10/60	-		16	2B					
Pictorial Corrected												
TOLERANCES			SCALE: FULL									
DEC. DIM. ±			MAXIMUM ALLOWABLE TOLERANCES HAVE BEEN DETERMINED AND ANY DEVIATIONS WILL BE CAUSE FOR REJECTION: REMOVE ALL BURRS AND SHARP EDGES									
FRAC. DIM. ± 1/64												
ANGULAR DIM. ±												
								6063-T5		W.F.	file	2B
								TYPE & TEMPER	HEATTREAT. SPEC.	DRAWN	CHECKED	FINAL APPROVAL
								S404 YEL IRIDITE		2B	W.D.	PM-590
								FINISH & SPEC. NO.	ELEC. DES. APP.	MECH. DES. APP.		D