

REQ. PER. UNIT	USED ON			PM-549	D
	MODEL	ASS'Y. NO.	DATE		
1	GPT-10K	RF DECK	2-12-59		

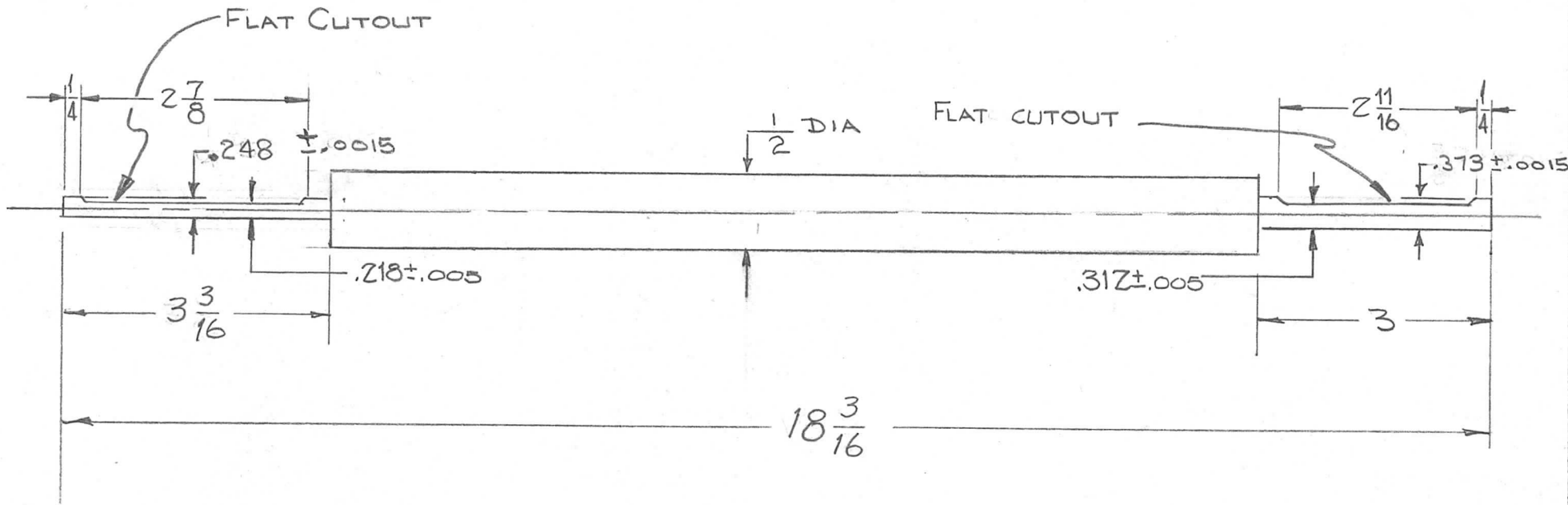

D		248 WAS .250, .373 WAS .375	6-27-62	6820	R.T.	file	9/12	REQ.	ITEM	PART NO.	DESCRIPTION	SYMBOL					
C	1	ADDED FLAT CUTOUTS	10-28-59	1490	DM	gob	9/16	1/2 DIA			THE TECHNICAL MATERIEL CORP.						
B	2	18-3/16 DIM WAS 18 1/2	3/31/59	—	file			STOCK SIZE			MAMARONECK, NEW YORK						
B	1	3-3/16 DIM WAS 3-1/2	2/20/59	821	file			STAINLESS STEEL			MAIN SHAFT						
A	1	TOL WAS .015						MATERIAL			ANT. TUNER GPT-10K						
ISSUE	ITEM	CHANGED FROM	DATE	CH. NO.	DRAFTS	CHECKER	ENG. APP.	#303			file	2/20	9/16				
TOLERANCES			SCALE:					TYPE & TEMPER		HEAT TREAT. SPEC.	DRAWN	CHECKED	FINAL APPROVAL				
DEC. DIM. ±			MAXIMUM ALLOWABLE TOLERANCES HAVE BEEN DETERMINED AND ANY DEVIATIONS WILL BE CAUSE FOR REJECTION. REMOVE ALL BURRS AND SHARP EDGES										PM-549 D				
FRAC. DIM. ± 1/64																	
ANGULAR DIM. ±																	
								FINISH & SPEC. NO.		ELEC. DES. APP	MECH. DES. APP						