

REQ. PER UNIT	USED ON		
	MODEL	ASS'Y. NO.	DATE
7	GPT-10K	AX-17Z	1-5-59

PM-525 G

NOTICE TO PERSONS RECEIVING THIS DRAWING

THE TECHNICAL MATERIEL CORPORATION claims proprietary right in the material disclosed hereon. This drawing is issued in confidence for engineering information only and may not be reproduced or used to manufacture anything shown hereon without permission from THE TECHNICAL MATERIEL CORPORATION to the user. This drawing is loaned for mutual assistance and is subject to recall at any time.

Property of:
 THE TECHNICAL MATERIEL CORPORATION
 MAMARONECK, NEW YORK

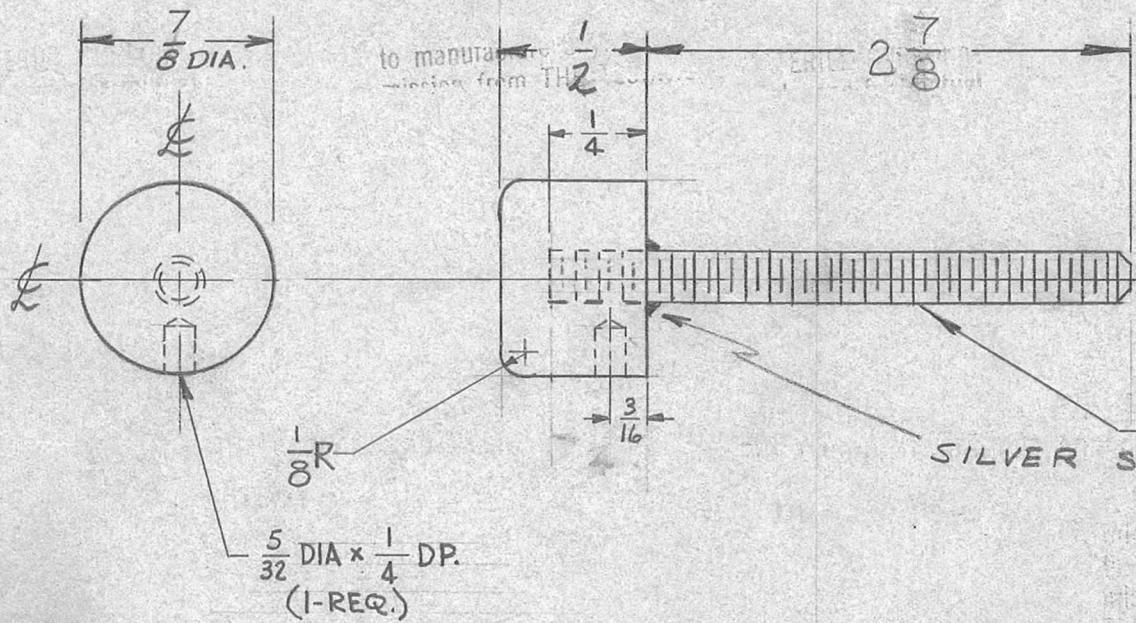

G		2-7/8 WAS 3-1/4	7-15-66	16551	WFW	JCB	ARB
F	1	5/32 DIA x 1/4 DP HOLE ADDED	9-12-62	7201	G.S.	JDe	ARB
E	1	10-32 THD WAS 1/4-20	8-8-60	#	CY	JCB	ARB
D	1	3/4 WAS 2 7/8	1-20-60	1789	M.G.		ARB

C	1	Thds. were 10-32 2 7/8 WAS 2 1/2	8/12/59	-	16		ARB
B	2	1/8 R added	2/3/59	743	JDe	JB	ARB
	1	.159 DIM. Deleted					
	3	.159 DIM added					
A	2	Threaded rod added	1/27/59	711	J.C.	JDe	ARB
	1	Finish WAS Rodium.000025					

ISSUE	ITEM	CHANGED FROM	DATE	CH. NO.	DRAFTS	CHECKER	ENG. APP.
TOLERANCES		SCALE:					
DEC. DIM. ±		MAXIMUM ALLOWABLE TOLERANCES HAVE BEEN DETERMINED AND ANY DEVIATIONS WILL BE CAUSE FOR REJECTION. REMOVE ALL BURRS AND SHARP EDGES					
FRAC. DIM. ±							
ANGULAR DIM. ±							

REQ.	ITEM	PART NO.	DESCRIPTION	SYMBOL
			THE TECHNICAL MATERIEL CORP. MAMARONECK, NEW YORK	
		7/8 DIA. ROD	CONTACT BUTTON	
		STOCK SIZE		
		BRASS		
		MATERIAL		
		HALF HARD		
		TYPE & TEMPER	DRAWN	CHECKED
		HEAT TREAT. SPEC.	ARB	JDe
		NICKEL PLATE	ARB	ARB
		FINISH & SPEC. NO.	ELEC. DES. APP	MECH. DES. APP
			PM-525	G