

REQ. PER UNIT	USED ON		PM-474
	MODEL	ASS'Y. NO.	
1	ATS-TU		12-18-57
1	ATS-50(70)TU2		6-8-59

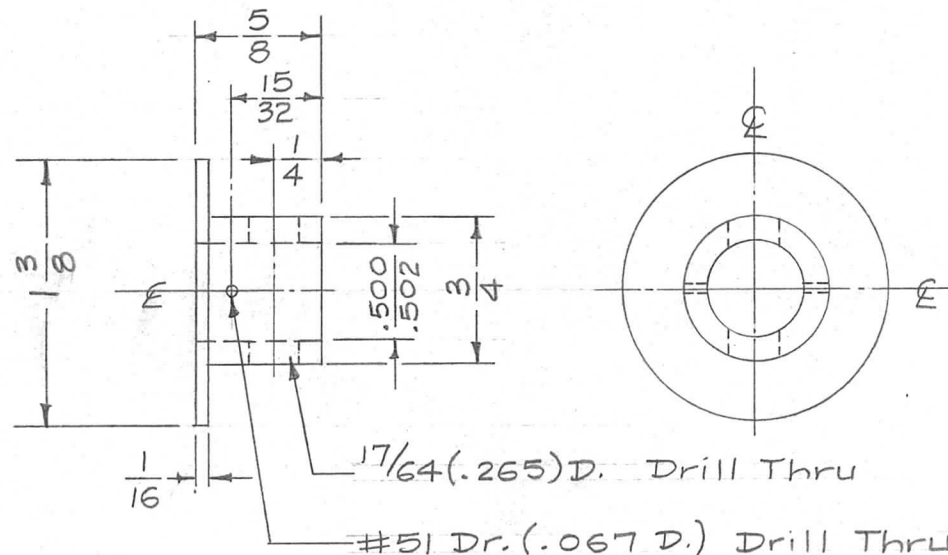

FINISH: S-245 SILVER PLATE .0005
S-423 IRIDITE 18-P SILVER KOTE

ISSUE	ITEM	CHANGED FROM	DATE	CH. NO.	DRAFTS	CHECKER	ENG. APP.	REQ. ITEM	PART NO.	DESCRIPTION	SYMBOL	
										THE TECHNICAL MATERIEL CORP. MAMARONECK. NEW YORK COLLAR, CONTACT SPRING		
									STOCK SIZE			
									BRASS			
									MATERIAL			
								HALF HARD	N	16 12/18/57	HAID	Chris Amis
								TYPE & TEMPER	HEAT TREAT. SPEC.	DRAWN	CHECKED	FINAL APPROVAL
								SEE NOTE		JSR	SAH	PM-474
								FINISH & SPEC. NO.		ELEC. DES. APP.	MECH. DES. APP.	

TOLERANCES
DEC. DIM. ±
FRAC. DIM. ± 1/64
ANGULAR DIM. ±

SCALE: FULL
MAXIMUM ALLOWABLE TOLERANCES HAVE BEEN DETERMINED AND ANY DEVIATIONS WILL BE CAUSE FOR REJECTION.
REMOVE ALL BURRS AND SHARP EDGES