

IF IT IS FOUND DESIRABLE TO CHANGE ANY TOLERANCE OR OTHER DETAIL SPECIFIED ON THIS DRAWING NOTIFY THE PURCHASER PROMPTLY.
 MAXIMUM ALLOWABLE TOLERANCES HAVE BEEN DETERMINED AND DEVIATIONS WILL BE CAUSE FOR REJECTION.
 REMOVE ALL BURRS AND SHARP EDGES

TMC PT NO.	AMT. PER UNIT	MODEL	PROJECT NO.	ASSY. NO.	DATE
	28	TAC-1	132	A-675 A-677 A-676 A-678	1-8-54
	3	ATS-50/70 TL	A3645		2-24-58

*.50 DRILL (.070) DIA, THRU (1)-REQ.

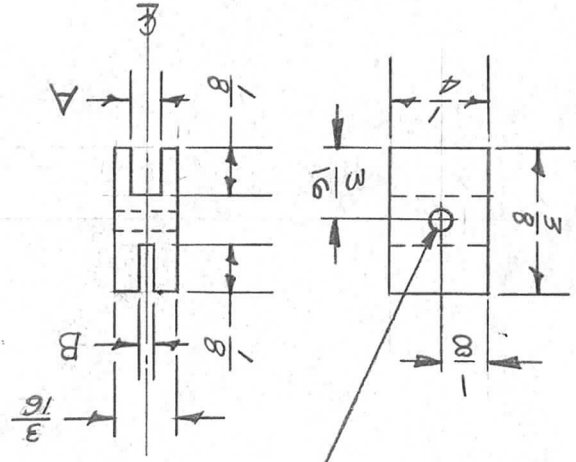

TMC NO.	"A"	"B"
PM 272-1	5/64	1/32
PM 272-2	1/16	1/32
PM 272-3	1/16	1/16

ISSUE ITEM	CHANGED FROM	DATE	CN. NO.	DRAFTS	CHECKER	ENG. APP.
E	ON CHART ADDED "B" DIM # PM 272-3	1-27-6	213.49	G.D.T.	A. D.	
D	TYPE COLU. ADD. (#2 W. AM 69)	2.13.65	13466	MR		
D	DIM "A" CHART ADDED					
C	ASSY NO. A169 ADDED					
C	.50 DRILL ADDED	7-29-64	11944			
B	3/16 WAS 5/32	11/11/57	2			
B	QUAN. REQ. WAS 30	3/14/59	1			

DEC. DIM. ±
 ALL FRACTIONAL DIM. ± 1/64
 ANGULAR DIM. ±

TOLERANCES
 SCALE TWICE
 DRILL, PUNCH, COMMERCIAL STOCK
 SIZES AND MANUFACTURERS
 TOLERANCES ARE NOT INCLUDED.

REQ. ITEM	PART NO.	DESCRIPTION	SYMBOL
		THE TECHNICAL MATERIEL CORP. MAMARONECK, NEW YORK	
		STOCK SIZE	
		MATERIAL	BRASS
		WEIGHT PER PC.	
		TYPE & TEMPER	HALF HARD
		DRAWN	ARB
		ELEC. DES. APP.	ARB
		MECH. DES. APP.	ARB
		CHECKED	ARB
		FINAL APPROVAL	ARB
		FINISH & SPEC. NO.	PM-272 E