

REQ. PER UNIT	USED ON			PM-249	A
	MODEL	ASS'Y. NO.	DATE		
2	XFK	A-684	10-5-53		

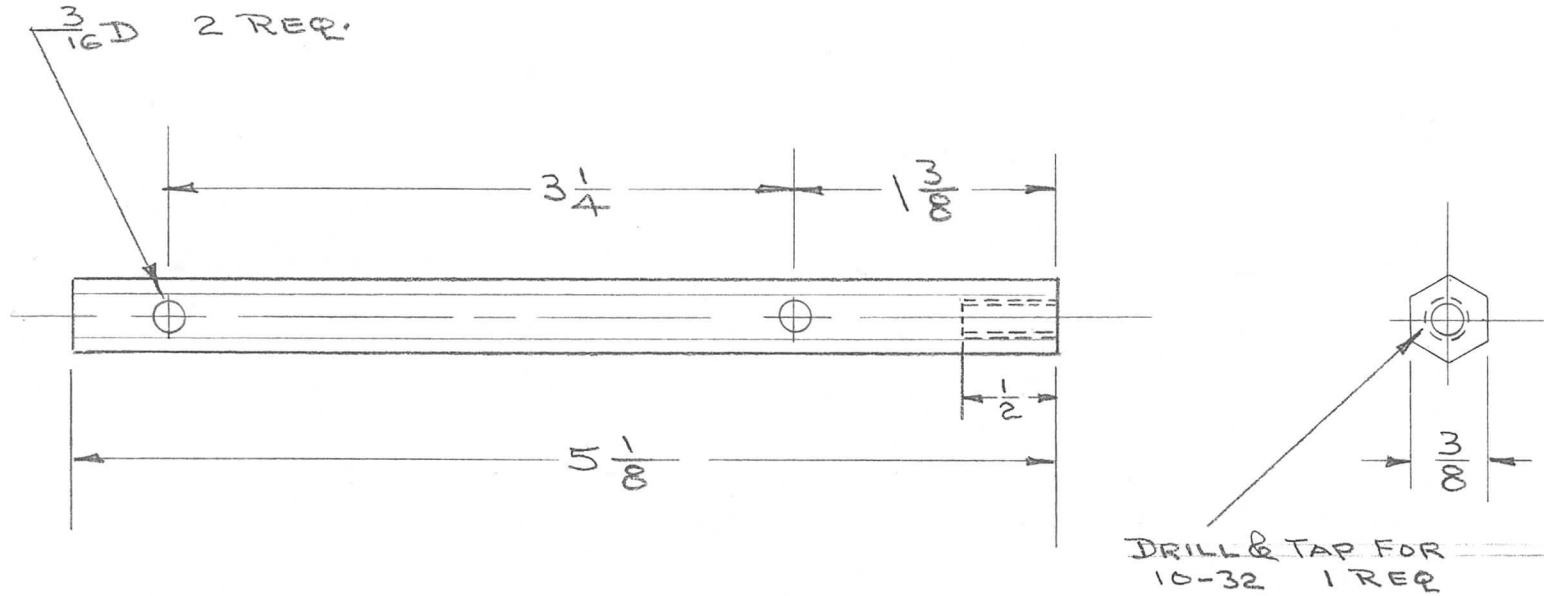

ISSUE	ITEM	CHANGED FROM	DATE	CH. NO.	DRAFTS	CHECKER	ENG. APP.	REQ. ITEM	PART NO.	DESCRIPTION	SYMBOL	
									3/8 HEX	THE TECHNICAL MATERIEL CORP. MAMARONECK, NEW YORK	TRANSFORMER SUPPORT	
									STOCK SIZE			
A	1	REDRAWN NO REVISION	4/10/58	1	HL				ALUMINUM			
									MATERIAL			
TOLERANCES			SCALE: $\frac{1}{1}$					245-T4	16	10-5-53	HL	
DEC. DIM. $\pm$			MAXIMUM ALLOWABLE TOLERANCES HAVE BEEN DETERMINED AND ANY DEVIATIONS WILL BE CAUSE FOR REJECTION.					TYPE & TEMPER	HEAT TREAT. SPEC.	DRAWN	CHECKED	FINAL APPROVAL
FRAC. DIM. $\pm$	1/64		REMOVE ALL BURRS AND SHARP EDGES					S-101 CAUSTIC DIP				
ANGULAR DIM. $\pm$								5107 LACQUER DIP				
								FINISH & SPEC. NO.	ELEC. DES. APP.	MECH. DES. APP.	PM-249	A