

IF IT IS FOUND DESIRABLE TO CHANGE ANY TOLERANCE OR OTHER DETAIL SPECIFIED ON THIS DRAWING NOTIFY THE PURCHASER PROMPTLY.

PM-218

MAXIMUM ALLOWABLE TOLERANCES HAVE BEEN DETERMINED AND DEVIATIONS WILL BE CAUSE FOR REJECTION. REMOVE ALL BURRS AND SHARP EDGES

REQ. PER UNIT

USED ON

2

MODEL  
DAC

PROJECT NO.  
180

ASS'Y. NO.  
A-623

DATE  
12-9-53

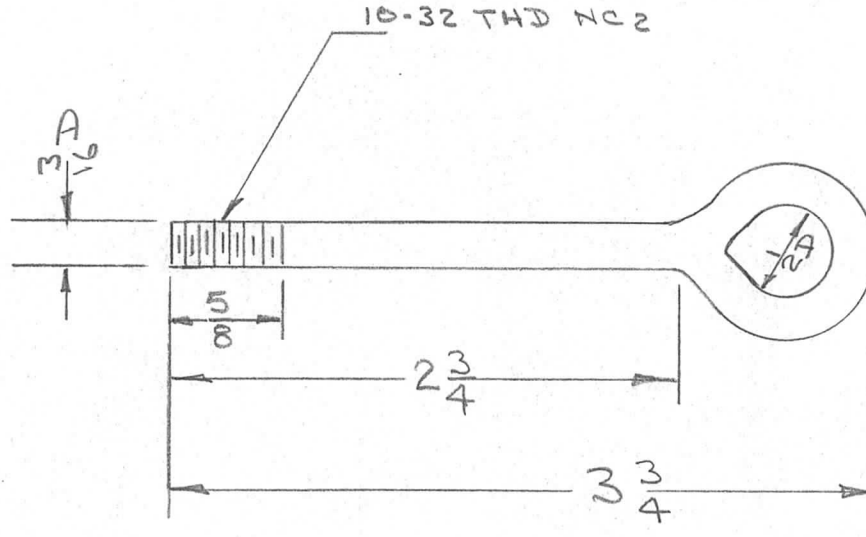

REQ.	ITEM	PART NO.	DESCRIPTION	SYMBOL
		3/16 D ROD	THE TECHNICAL MATERIEL CORP.	
		STOCK SIZE	MAMARONECK. NEW YORK	
		BRASS	STUD BOLT	
		MATERIAL	WEIGHT PER PC.	
		FREE TURNING		
		TYPE & TEMPER		
		HEAT TREAT. SPEC.		
		S-105 .0002		
		CADMIUM PLATE		
		FINISH & SPEC. NO.		

ISSUE ITEM CHANGED FROM DATE CN. NO. DRAFTS CHECKER ENG. APP.

TOLERANCES

SCALE

ALL OTHERS  
DEC. DIM.  $\pm$   
FRAC. DIM.  $\pm$   
ANGULAR DIM.  $\pm$   $\frac{1}{32}$

DRILL, PUNCH, COMMERCIAL STOCK SIZES AND MANUFACTURERS TOLERANCES ARE NOT INCLUDED.

DRAWN: JAW  
ELEC. DES. APP.: APB  
MECH. DES. APP.: WDE  
CHECKED: C.W.D.  
FINAL APPROVAL: APB

PM-218