

5

4

3

2

1

REVISIONS							
E.M.N. NO.	DRAFT	CHKD	ZONE	LTR	DESCRIPTION	DATE	APPROVED

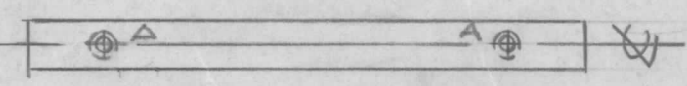
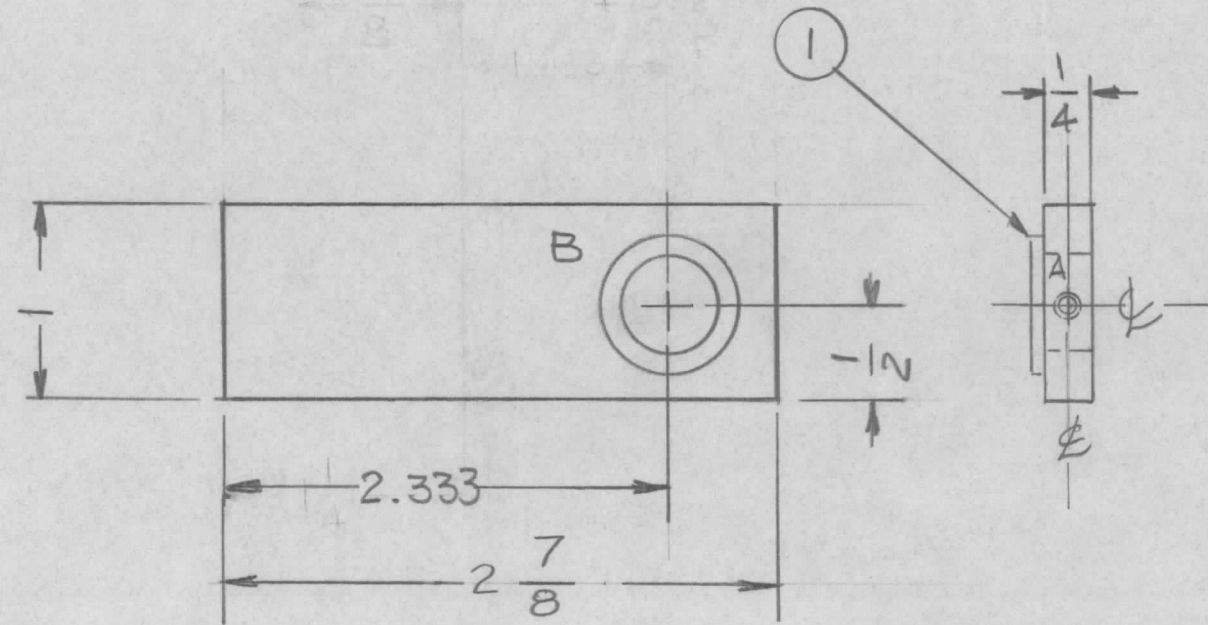
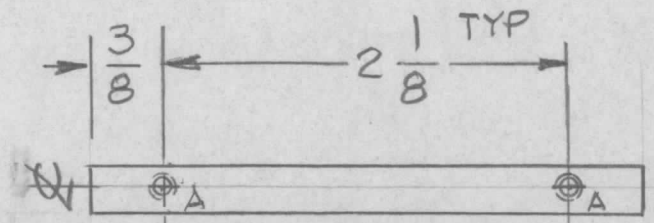

2 PM -1 AS SHOWN
 1 PM -2 WELDED

HOLES:
 A - DRILL & TAP FOR .440 6 REQ
 B - .5000 ^{+0.0005} _{-.0000} DIA. 1 REQ.

1	1	BB118-37	BEARING CYLINDRICAL	
REQ'D	ITEM	PART NUMBER	DESCRIPTION	SYM.

LIST OF MATERIAL

2	GPT-10KLF	A5703
QTY / UNIT	MODEL USED ON	ASS'Y NO.
APPLICATION		
	CODE	

UNLESS OTHERWISE SPECIFIED DIMENSIONS ARE IN INCHES AND INCLUDE CHEMICALLY APPLIED OR PLATED FINISHES		FINAL APPROVAL	DATE
		MECH. DES.	DATE
		ELECT. DES.	DATE
		CHECKED	DATE
		DRAWN	DATE
MATERIAL 1/4 THK ALUM 2024-T3		G.D.L.	4-13-77
FINISH S404 YEL. IRIDITE			

THE TECHNICAL MATERIEL CORP.
 MAMARONECK, NEW YORK

PLATE MTG BEARING

NOTICE TO PERSONS RECEIVING THIS DRAWING
 THE TECHNICAL MATERIEL CORPORATION claims proprietary right in the material disclosed hereon. This drawing is issued in confidence for engineering information only and may not be reproduced or used to manufacture anything shown hereon without permission from THE TECHNICAL MATERIEL CORPORATION to the user. This drawing is loaned for mutual assistance and is subject to recall at any time.

SIZE	CODE IDENT. NO.	DWG NO.	ISSUE
B	82679	PM 1595	
SCALE	1:1	SHEET	OF

5

4

3

2

1