

REQ. PER UNIT	USED ON			PM1261	Ø
	MODEL	ASS'Y. NO.	DATE		
1	TST( )10K	A5286	5-14-65		

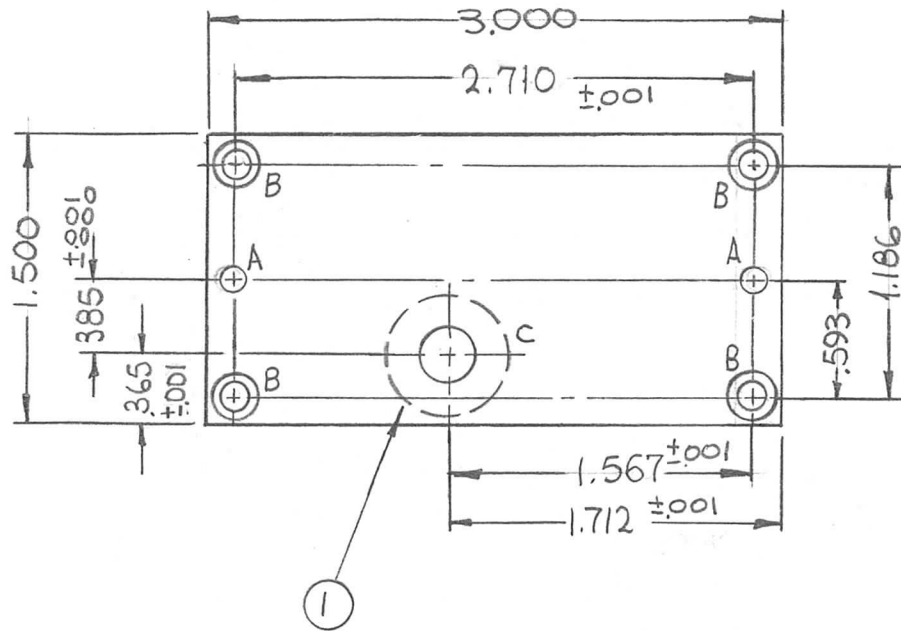

HOLES	DESCRIPTION	REQ.
A	.126 ±.001 DIA.	2
B	DR. 9/64 DIA. C'BORE .218 DIA. X 5/32 DP.	4
C		1

							1	1	BB120-1	BEARING, BALL	C	
							REQ. ITEM	PART NO.	F. BUDETTI	DESCRIPTION	SYMBOL	
							1/4 THICK		THE TECHNICAL MATERIEL CORP. MAMARONECK, NEW YORK			
							STOCK SIZE		PLATE, FRONT, GEAR BOX			
Ø	ORIGINAL RELEASE	4-12-66	Ø	G.D.L.			ALUMINUM					
SYM	DESCRIPTION	DATE	CH. NO.	DRAFTS	CHECKER	ENG. APP.	MATERIAL					
UNLESS OTHERWISE SPECIFIED DIMENSIONS ARE IN INCHES AND INCLUDE CHEMICALLY APPLIED OR PLATED FINISHES		SCALE						2024-T4	Ø	SRG		
		1:1						TYPE & TEMPER	HEAT TREAT. SPEC.	DRAWN	CHECKED	FINAL APPROVAL
DECIMALS .X ±.05 .XX ±.01 .XXX ±.005	TOLERANCES	FRACTIONS ± 1/64 ANGLES ± 0° 30'	CODE A					S404 YEL. IRIDITE	Ø	Ø	Ø	Ø
								FINISH & SPEC. NO.	ELEC. DES. APP.	MECH. DES. APP.	PM1261	Ø