

REQ. PER UNIT	USED ON			PM1115	⊗
	MODEL	ASS'Y. NO.	DATE		
1	RTMU-1	A3909	6/24/64		

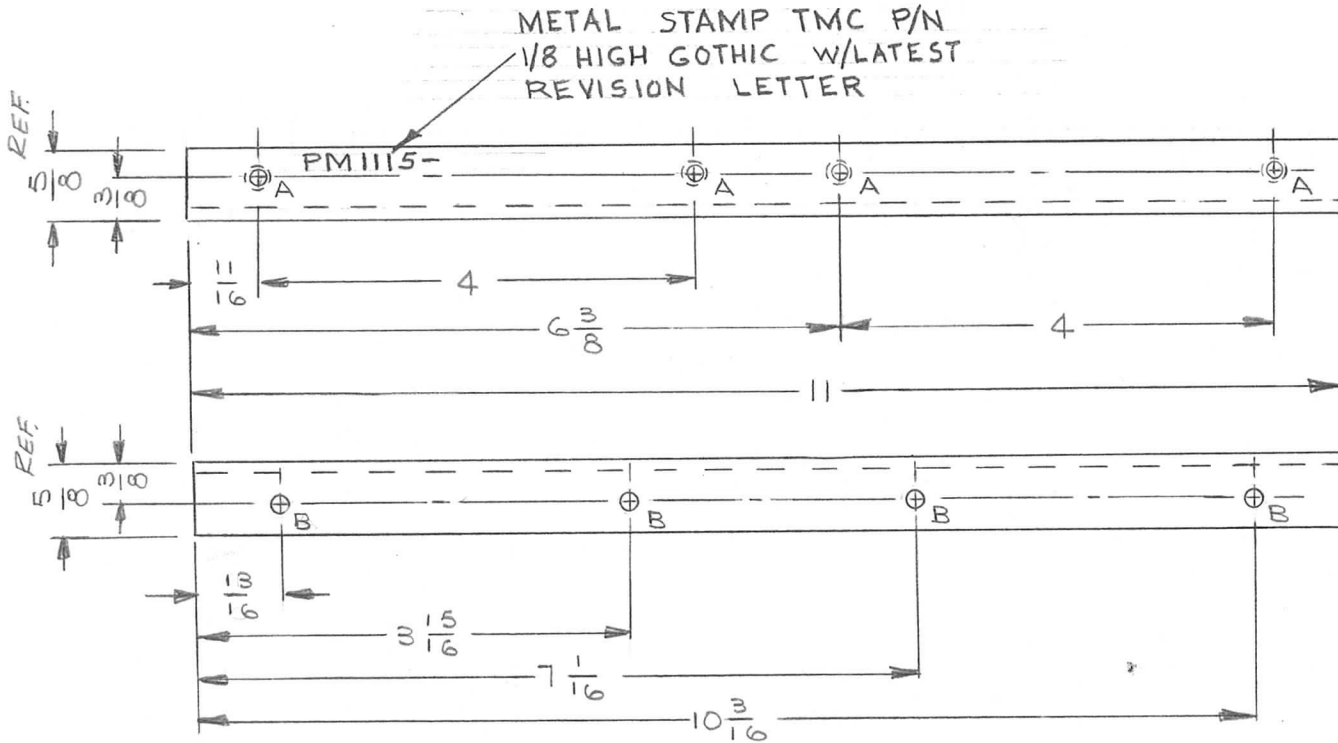

HOLE LEGEND		
HOLE	DESCRIPTION	REQ'D
A	.221-.224 DIA	4
B	3/16 DIA	4

REMOVE ALL BURRS & SHARP EDGES.

4	1	NT-129-832-6	NUT, PLAIN, SPLINE TYPE			
REQ. ITEM	PART NO.		EATON	DESCRIPTION SK 3071 PM7	SYMBOL	
⊗	ORIGINAL RELEASE FOR PRODUCTION	1-18-65	⊗	JM	EXTRUDED ANGLE 5/8 X 5/8 X 1/8 THK STOCK SIZE	
X	EXPERIMENTAL RELEASE	11/6/64			ALUMINUM	
SYM	DESCRIPTION	DATE	CH. NO.	DRAFTS	CHECKER	ENG. APP.
	UNLESS OTHERWISE SPECIFIED DIMENSIONS ARE IN INCHES AND INCLUDE CHEMICALLY APPLIED OR PLATED FINISHES	SCALE	NONE			
DECIMALS .X ± .05 .XX ± .01 .XXX ± .005	TOLERANCES	FRACTIONS ± 1/64 ANGLES ± 0° 30'	CODE	A		
		6063 T5		—M		JL
		YELLOW IRIDITE PER S404		1/18/65		W. J. [Signature]
		FINISH & SPEC. NO.		ELEC. DES. APP.		MECH. DES. APP.
		JL		[Signature]		[Signature]
		DRAWN		CHECKED		FINAL APPROVAL
		ELEC. DES. APP.		MECH. DES. APP.		PM1115