

REQ. PER UNIT	USED ON		PM 1102	∅
	MODEL	ASS'Y. NO.		
	VLRB-1		8-28-64	

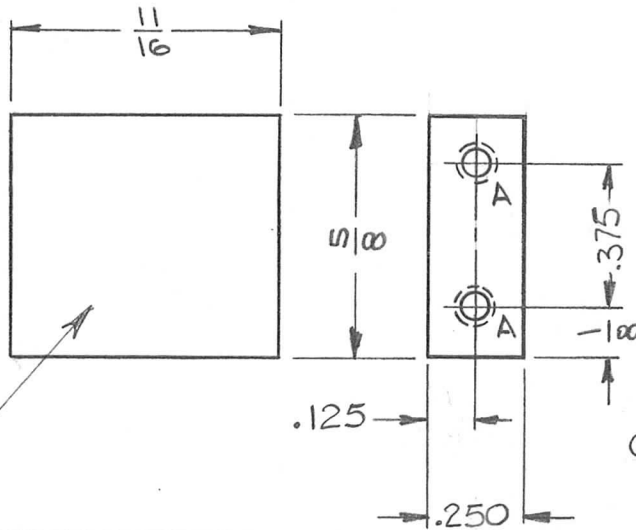

HOLE	DESCRIPTION	REQ.
A	DRILL & TAP #2-56 x 1/4 DP.	4

OPPOSITE SIDE IDENTICAL

METAL STAMP TMC  
PART NO. 1/8 HIGH  
GOTHIC W/LATEST  
REV. LETTER

REMOVE ALL BURRS AND SHARP EDGES

SYM	DESCRIPTION	DATE	CH. NO.	DRAFTS	CHECKER	ENG. APP.	REQ. ITEM	PART NO.	DESCRIPTION	SYMBOL		
∅	ORIGINAL RELEASE FOR PRODUCTION	9/1/65					AS NOTED		THE TECHNICAL MATERIEL CORP. MAMARONECK, NEW YORK	POSE		
XI	DIMENSIONS IN DECIMAL WERE IN FRACTION	12-2-64					STOCK SIZE					
X	EXPER. RELEASE	8-28-64	X				STAINLESS STEEL		SPACER, SLIDE & INDICATOR			
							MATERIAL					
	UNLESS OTHERWISE SPECIFIED DIMENSIONS ARE IN INCHES AND INCLUDE CHEMICALLY APPLIED OR PLATED FINISHES	SCALE	2:1				#303					
	DECIMALS .X ± .05 .XX ± .01 .XXX ± .005	FRACTIONS ± 1/64 ANGLES ± 0° 30'	CODE	A				TYPE & TEMPER	HEAT TREAT. SPEC.	DRAWN	CHECKED	FINAL APPROVAL
	TOLERANCES						S104 - PASSIVATE					PM 1102
							FINISH & SPEC. NO.		ELEC. DES. APP.	MECH. DES. APP.		∅