

IF IT IS FOUND DESIRABLE TO CHANGE ANY TOLERANCE OR OTHER DETAIL SPECIFIED ON THIS DRAWING NOTIFY THE PURCHASER PROMPTLY.

PM-195 A

MAXIMUM ALLOWABLE TOLERANCES HAVE BEEN DETERMINED AND DEVIATIONS WILL BE CAUSE FOR REJECTION. REMOVE ALL BURRS AND SHARP EDGES

REQ. PER UNIT	USED ON			
	MODEL	PROJECT NO.	ASS'Y. NO.	DATE
2	VOX	101		1-24-55
2	VOX-1-2	291		1-24-55

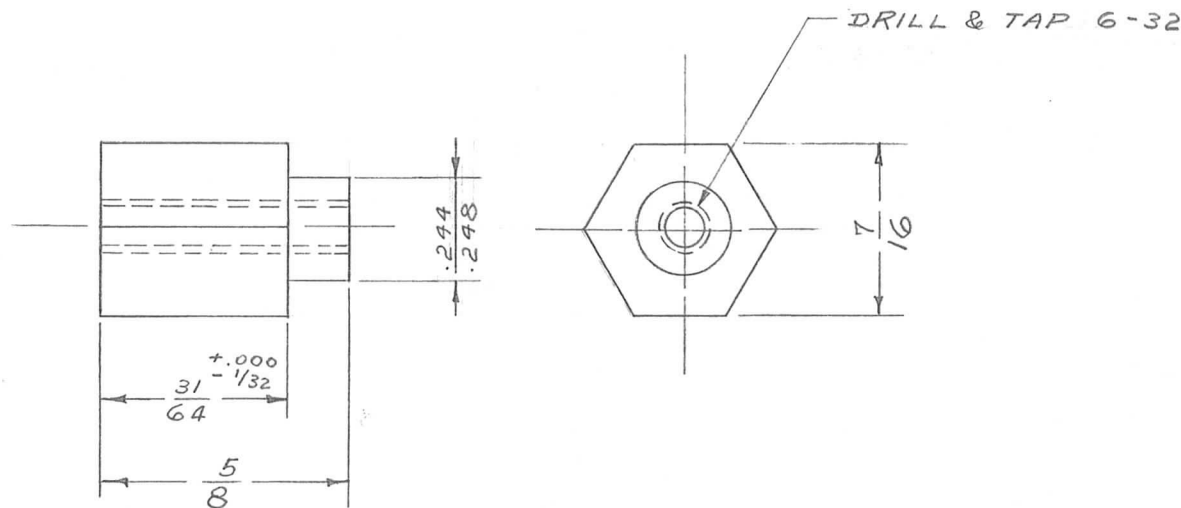

REQ.	ITEM	PART NO.	DESCRIPTION	SYMBOL
	HEX ROD		THE TECHNICAL MATERIEL CORP.	
	STOCK SIZE		MAMARONECK, NEW YORK	
	BRASS	—#—	PIVOT STUDS	
	MATERIAL	WEIGHT PER PC.		
	FREE TURNING			
	TYPE & TEMPER		P.B. 1-24-55	
	—#—		DRAWN	ELEC. DES. APP. MECH. DES. APP.
	HEAT TREAT. SPEC.		1-24-55	
	S-105 CADMIUM PLATE		CHECKED	FINAL APPROVAL
	.0002			
	FINISH & SPEC. NO.			

#	#	REDRAWN NO CHANGE	#	DATE	CN. NO.	DRAFTS	CHECKER	ENG. APP.

TOLERANCES	SCALE
DEC. DIM. \pm FRAC. DIM. \pm $\frac{1}{64}$ ANGULAR DIM. \pm	DRILL, PUNCH, COMMERCIAL STOCK SIZES AND MANUFACTURERS TOLERANCES ARE NOT INCLUDED.

PM-195 A