

IF IT IS FOUND DESIRABLE TO CHANGE ANY TOLERANCE OR OTHER DETAIL SPECIFIED ON THIS DRAWING NOTIFY THE PURCHASER PROMPTLY.

RELEASED

PM-179

MAXIMUM ALLOWABLE TOLERANCES HAVE BEEN DETERMINED AND DEVIATIONS WILL BE CAUSE FOR REJECTION. REMOVE ALL BURRS AND SHARP EDGES

USED ON

MODEL	PROJECT NO.	ASS'Y. NO.	DATE
R-8	168	A-288	12-3-52
R-10	168	A-288	12-3-52
R-12	168	A-288	12-3-52

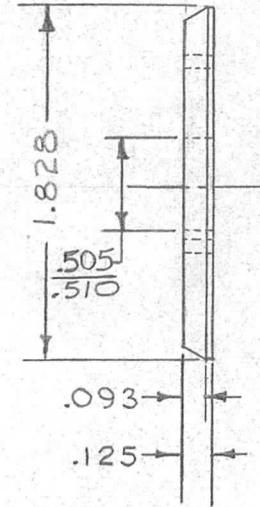
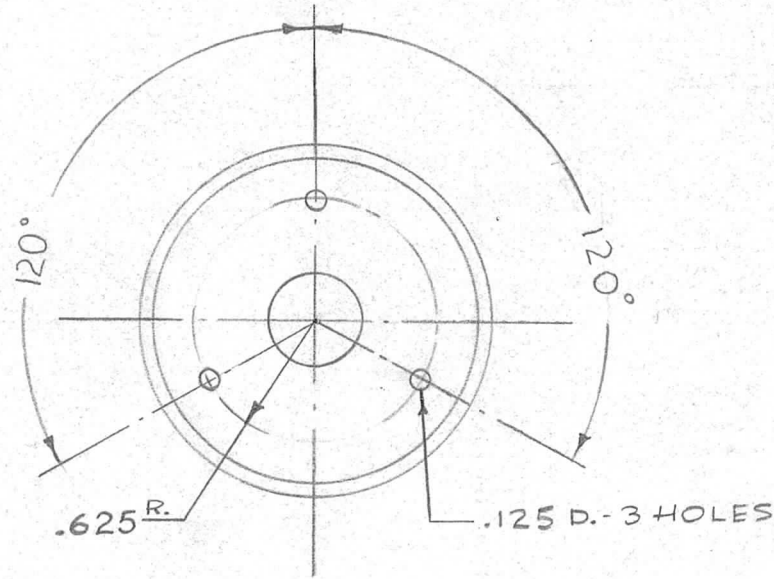

REQ.	ITEM	PART NO.	DESCRIPTION	SYMBOL
		<i>ff</i>	THE TECHNICAL MATERIEL CORP. MAMARONECK, NEW YORK	
		STOCK SIZE		
		BRASS	CLUTCH FACE	
		MATERIAL		
		WEIGHT PER PC.		
		FREE TURNING		
		TYPE & TEMPER	16 12-3-52	
			DRAWN	ELEC. DES. APP. MECH. DES. APP.
			HEAT TREAT. SPEC.	
		(S-135) NICKEL PLATE	12-15-52	FINAL APPROVAL
		FINISH & SPEC. NO.		

<input checked="" type="checkbox"/>	ORIGINAL RELEASE	9/26/69	(C)			
ISSUE	ITEM	CHANGED FROM	DATE	CN. NO.	DRAFTS CHECKER	ENG. APP.
TOLERANCES			SCALE FULL SIZE			
ALL OTHERS	DEC. DIM. ± .005	FRAC. DIM. ±	ANGULAR DIM. ± 1°	DRILL, PUNCH, COMMERCIAL STOCK SIZES AND MANUFACTURERS TOLERANCES ARE NOT INCLUDED.		

PM-179