

REQ. PER UNIT	USED ON			PM1069	Ø
	MODEL	ASS'Y. NO.	DATE		
1	AF-107	A5582	12-6-66		

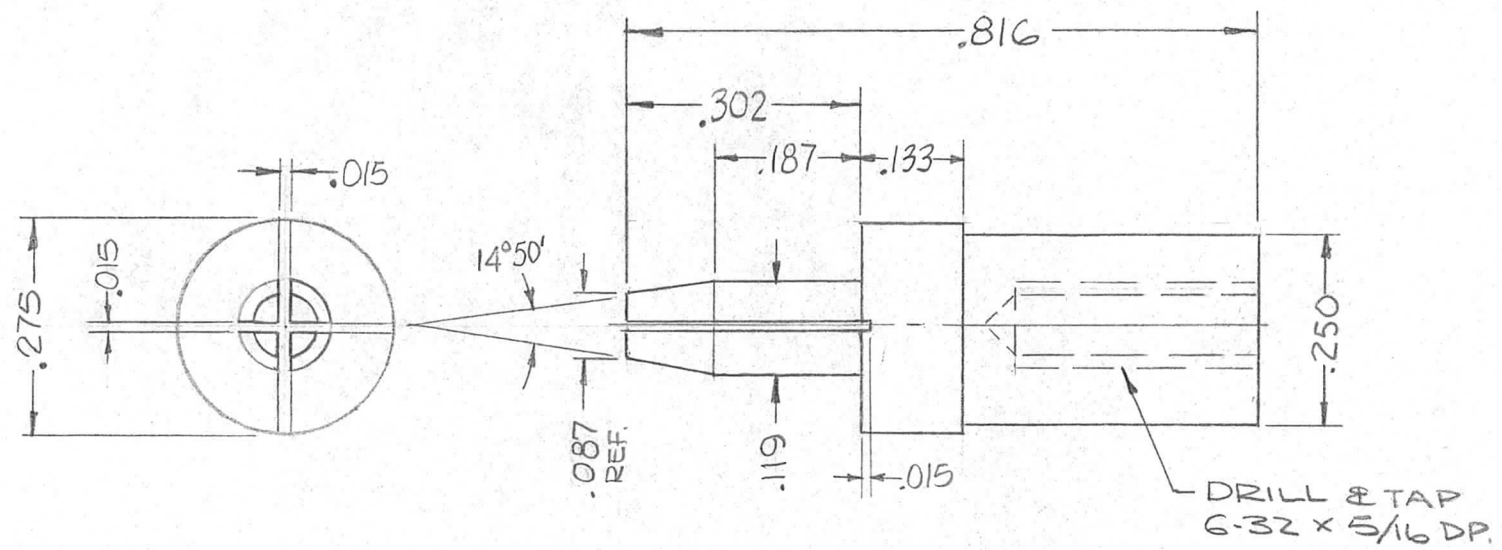

NOTE:
REMOVE SHARP EDGES,

REQ. ITEM	PART NO.	F. BUDETTI	DESCRIPTION	SYMBOL											
Ø	AS SHOWN		THE TECHNICAL MATERIEL CORP. MAMARONECK. NEW YORK												
X	COPPER		CONTACT, ELEC.												
ISSUE ITEM	CHANGED FROM	DATE	CH. NO.	DRAFTS	CHECKER	ENG. APP.	MATERIAL								
TOLERANCES		SCALE: 4:1		HARD DRAWN		TYPE & TEMPER		HEAT TREAT. SPEC.		DRAWN		CHECKED		FINAL APPROVAL	
DEC. DIM. ±	S401-181	MAXIMUM ALLOWABLE TOLERANCES HAVE BEEN DETERMINED AND ANY DEVIATIONS WILL BE CAUSE FOR REJECTION.		3245 SIL. PLATE		W								PM1069	
FRAC. DIM. ±		REMOVE ALL BURRS AND SHARP EDGES		S423 SIL KOTE										Ø	
ANGULAR DIM. ±				FINISH & SPEC. NO.		ELEC. DES. APP.		MECH. DES. APP.							