

5

4

3

2

1

REVISIONS							
ZONE	LTR	DESCRIPTION	DATE	E.M.N.NO	DRAFT	CHKD	APPD

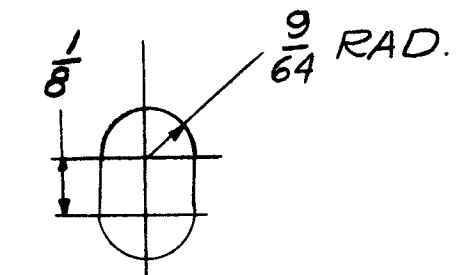
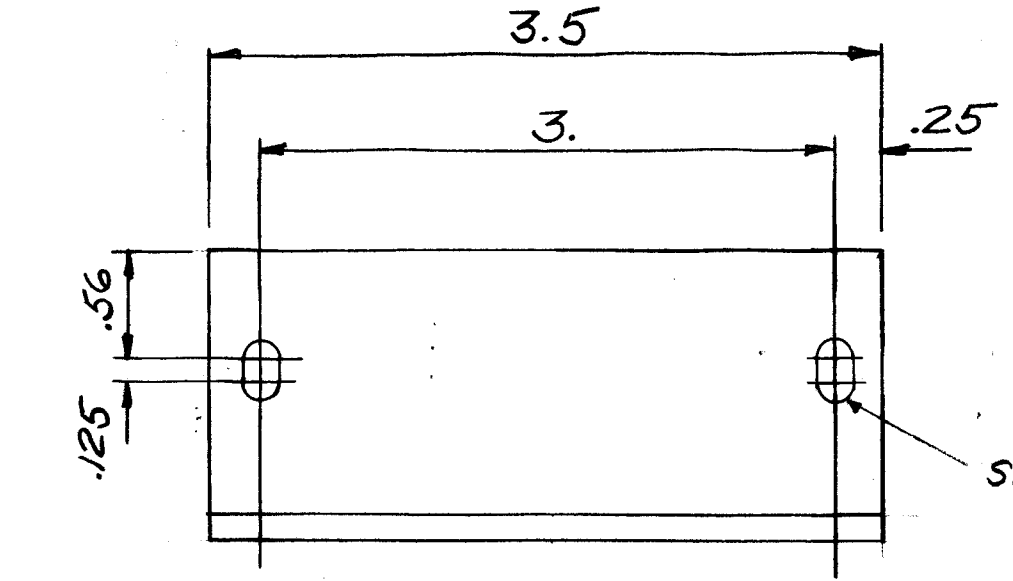

DETAIL A  
 B-(1). DRILL  
 C-(2). DRILL

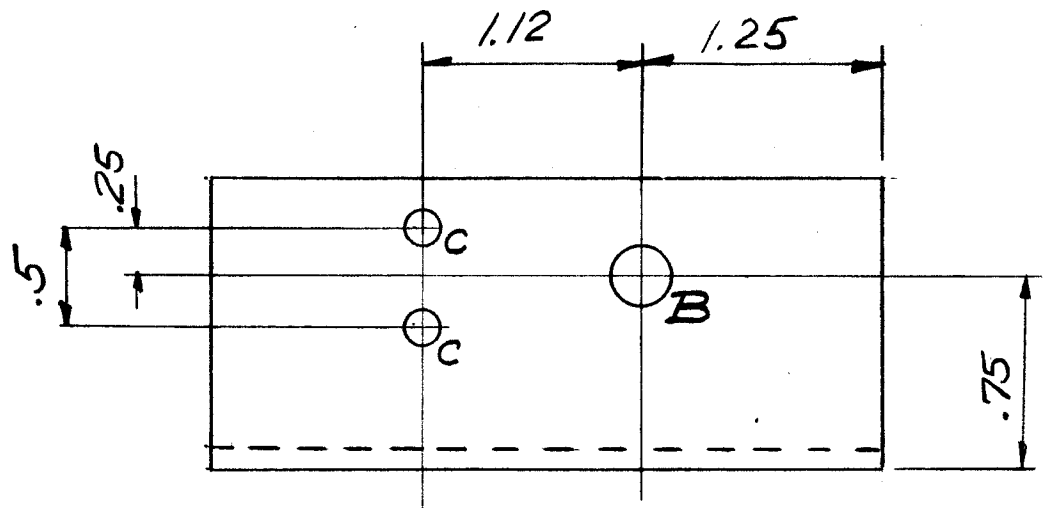

REQ'D	ITEM	PART NUMBER	DESCRIPTION	SYM.
-------	------	-------------	-------------	------

LIST OF MATERIAL

1 / 17A	AX 8047	A8033
QTY / UNIT	MODEL USED ON	ASS'Y NO.
APPLICATION		
CODE		

UNLESS OTHERWISE SPECIFIED DIMENSIONS ARE IN INCHES AND INCLUDE CHEMICALLY APPLIED OR PLATED FINISHES		FINAL APPROVAL <i>JMM</i>	DATE 2-1-68
DECIMALS .X ± .05	FRACTIONS 1/64	MECH. DES. <i>[Signature]</i>	DATE 12-5-68
.XX ± .01	TOLS. ANGLES	ELECT. DES. <i>[Signature]</i>	DATE 12-5-68
.XXX ± .005	0° - 30'	CHECKED <i>[Signature]</i>	DATE 12-70-68
MATERIAL 8 X 1 1/2 X 1 1/2 ALUM L	FINISH S404-IRIDITE	DRAWN <i>CB</i>	DATE 1-15-68

THE TECHNICAL MATERIEL CORP. MAMARONECK, NEW YORK			
LOCKING MECH. BKT.			
SIZE B	CODE IDENT. NO. 82679	DWG NO. MS8178	ISSUE Ø
SCALE FULL		SHEET 1 OF 1	

**NOTICE TO PERSONS RECEIVING THIS DRAWING**  
 THE TECHNICAL MATERIEL CORPORATION claims proprietary right in the material disclosed hereon. This drawing is issued in confidence for engineering information only and may not be reproduced or used to manufacture anything shown hereon without permission from THE TECHNICAL MATERIEL CORPORATION to the user. This drawing is loaned for mutual assistance and is subject to recall at any time.