

REQ. PER UNIT	USED ON			MS-3287 O
	MODEL	ASS'Y. NO.	DATE	
1	GPT-40KAP-118	A-3482	10-2-63	

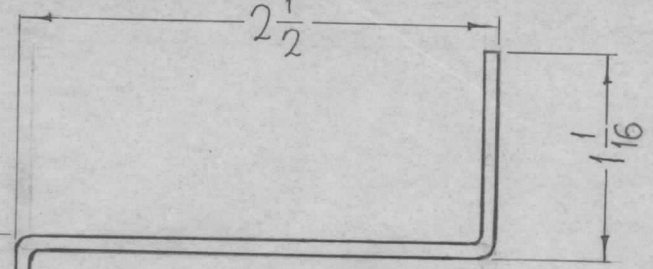
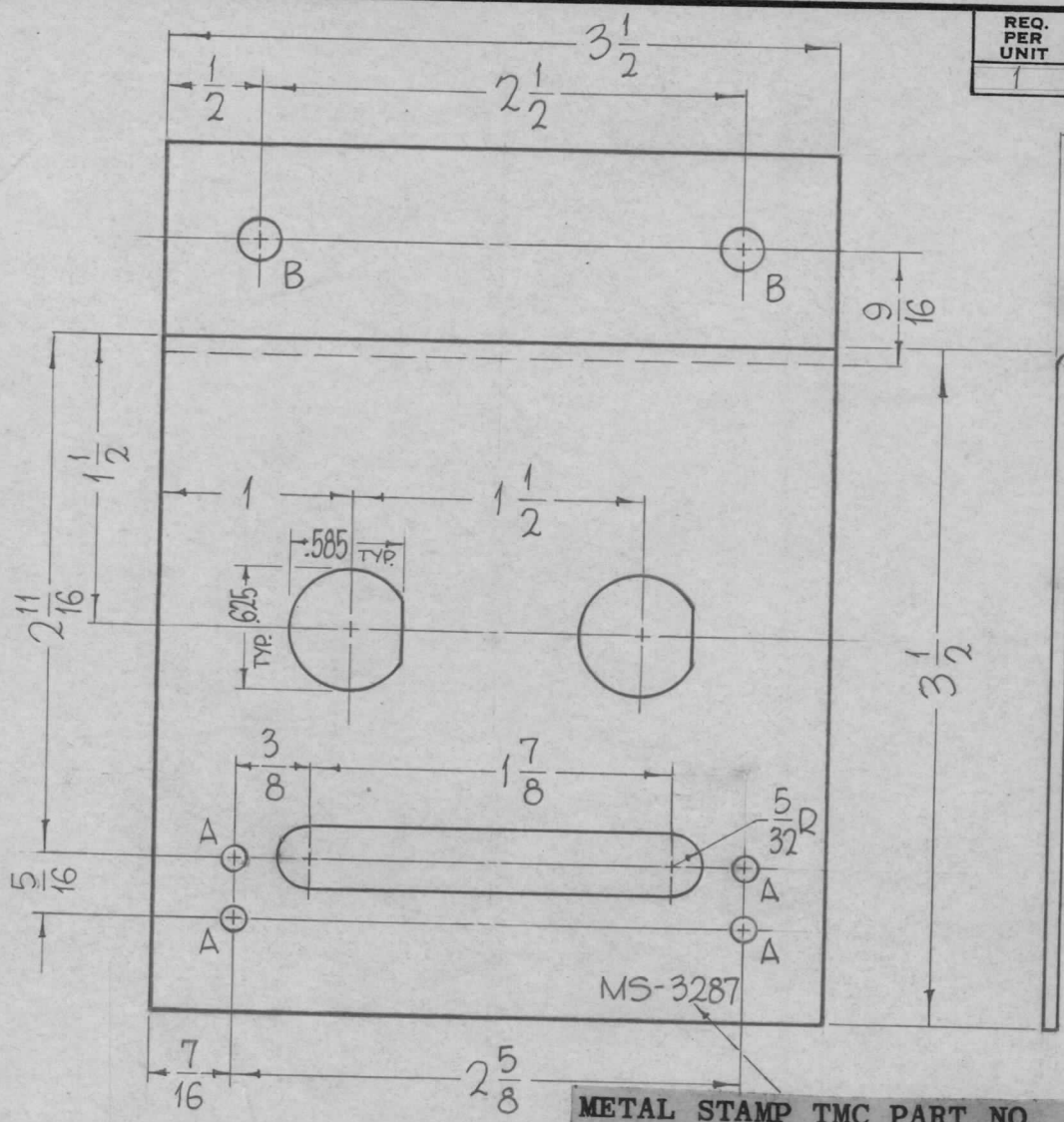

HOLES	REQ.
A - 1/8 DIA.	4
B - 15/64 DIA.	2

UNLESS OTHERWISE SPECIFIED:

1. USE MATERIAL THICKNESS FOR MAXIMUM RADIUS ON ALL BENDS.
2. ALL ANGULAR BENDS 90°.
3. REMOVE ALL BURRS AND SHARP EDGES.

METAL STAMP TMC PART NO. 1/8 HIGH GOTHIC. W/LATEST REV. REF. TMC DWG. LD-1247

REQ. ITEM	PART NO.	F. BUDETTI	DESCRIPTION	SYMBOL
	.081 THICK		THE TECHNICAL MATERIEL CORP.	
	STOCK SIZE		MAMARONECK, NEW YORK	
	ALUMINUM		BRACKET, COMPONENT MTG.	
	MATERIAL			
	5052, H-32	John C. Biele	aa	Rae
	TYPE & TEMPER	HEAT TREAT. SPEC.	DRAWN	CHECKED
	S404-IRIDITE, 14-2 AL. COAT		12/7/63	
	FINISH & SPEC. NO.	ELEC. DES. APP.	MECH. DES. APP.	MS-3287 O

UNLESS OTHERWISE SPECIFIED DIMENSIONS ARE IN INCHES AND INCLUDE CHEMICALLY APPLIED OR PLATED FINISHES

SCALE 1" = 1"

DECIMALS .X ± .05 .XX ± .01 .XXX ± .005

FRACTIONS ± 1/64 ANGLES ± 0° 30'

TOLERANCES A