

THE CONTENTS OF THIS DRAWING ARE THE EXCLUSIVE PROPERTY OF THE TECHNICAL MATERIEL CORP. ITS UNAUTHORIZED USE OR REPRODUCTION IN WHOLE OR IN PART IS STRICTLY FORBIDDEN.

REQ. PER UNIT

USED ON

MODEL

ASS'Y. NO.

DATE

QDS

9-7-62

MS-3015

B

~FINISHING NOTES~

1-5404 IRIDITE

2-FRONT & EDGES ONLY:

A-S114 ZINC CHROMATE PRIMER

B-S115 TMC SMOOTH GREY ENAMEL OR PRIME

& PAINT TO CUST. SPEC.

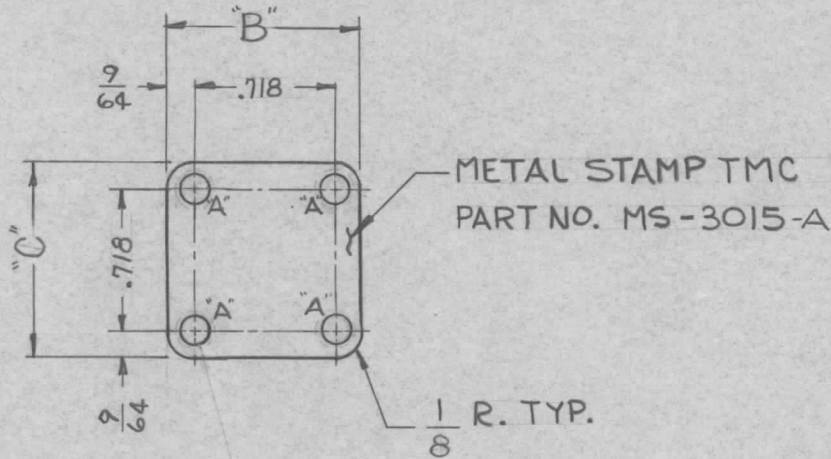

TMC PART NO.	"A"	"B"	"C"
MS-3015-1	9/64 DIA	1"	1"
MS-3015-2	4-40 DRILL & TAP	1"	1"
MS-3015-3	6-32 DRILL & TAP	1"	1"

UNLESS OTHERWISE SPECIFIED DIMENSIONS ARE IN INCHES AND INCLUDE CHEMICALLY APPLIED OR PLATED FINISHES

DECIMALS	FRACTIONS
.X ± .05	± 1/64
.XX ± .01	ANGLES
.XXX ± .005	± 0° 30'

TOLERANCES

CUT HERE GUARANTEED 2-66

REQ.	ITEM	PART NO.	MATERIAL				DESCRIPTION	SYMBOL
		1/8 4	ALUMINUM				THE TECHNICAL MATERIEL CORP. MAMARONECK, NEW YORK	
			2024-T3				COVER, BLANK	
			SEE FINISHING NOTES				QDS	
			FINISH & SPEC. NO.					
B	MS-3015-3 ADDED	8/27/65 14732	JVV	JCS	JMK			
A	CHART ADDED DIMS & THICKNESS CLARIFIED	10-4-62 7281	JS	HDE	JCS			
SYM	DESCRIPTION	DATE	CH. NO.	DRAFTS	CHECKER	ENG. APP.		
UNLESS OTHERWISE SPECIFIED: DIMENSIONS ARE IN INCHES TOLERANCES ON FRAC. ± 1/64 DEC. ± .005 ANGLES ± 1/2°		SCALE: DO NOT SCALE MAXIMUM ALLOWABLE TOLERANCES HAVE BEEN DETERMINED AND ANY DEVIATIONS WILL BE CAUSE FOR REJECTION. REMOVE ALL BURRS AND SHARP EDGES						
				9. Sancer 9-7-62		John	BP	
				DRAWN		CHECKED	FINAL APPROVAL	
				ELEC. DES. APP.		MECH. DES. APP.	MS-3015 B	