

MS-2840 A

THE CONTENTS OF THIS DRAWING ARE THE EXCLUSIVE PROPERTY OF THE TECHNICAL MATERIEL CORP. ITS UNAUTHORIZED USE OR REPRODUCTION IN WHOLE OR IN PART IS STRICTLY FORBIDDEN.

HOLES	DESCRIPTION	REQ.
A	3/64 DIA.	8

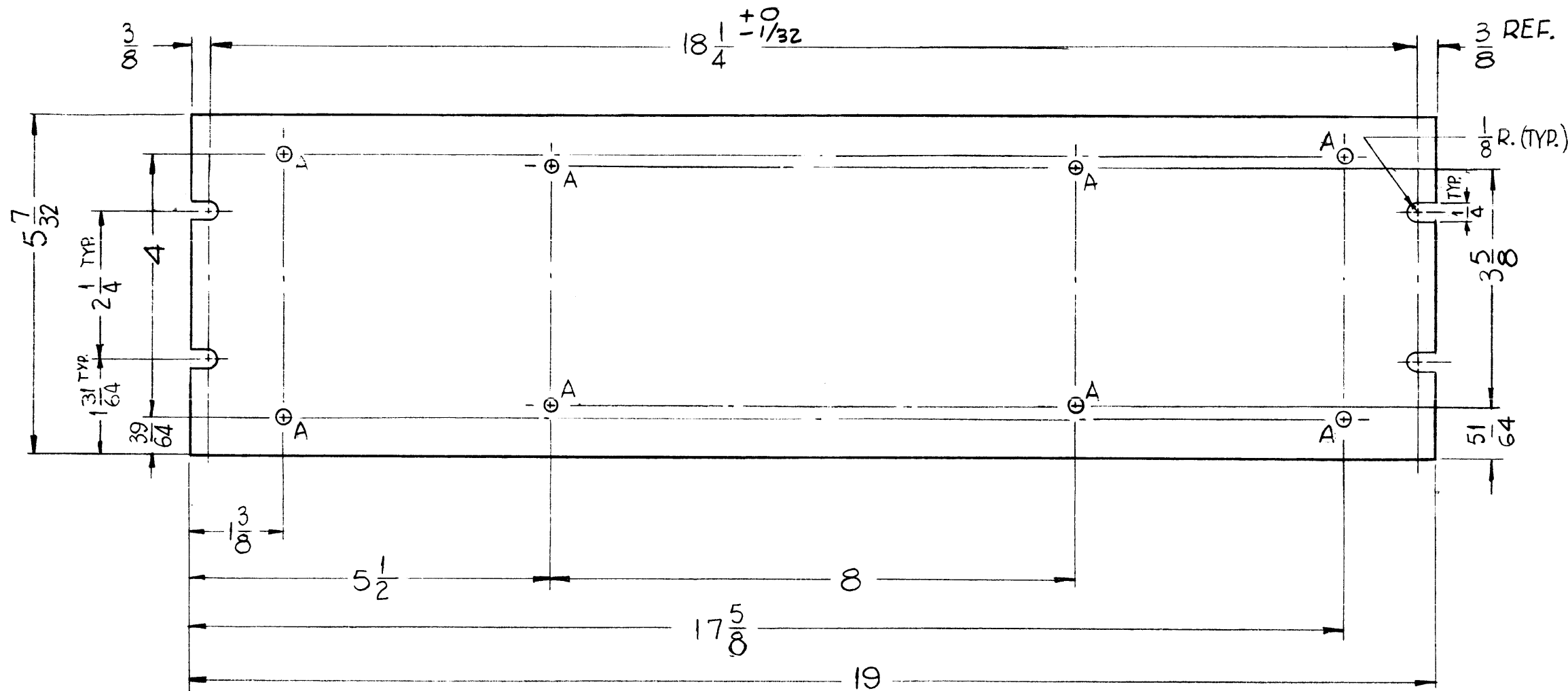

NOTE TO PERSONS VIEWING THIS DRAWING
 THE TECHNICAL MATERIEL CORPORATION claims proprietary right in the material disclosed herein. This drawing is issued in confidence for engineering information only and may not be reproduced or used to manufacture anything shown hereon without permission from THE TECHNICAL MATERIEL CORPORATION to the user. This drawing is loaned for mutual assistance and is subject to recall at any time.

Property of:
 THE TECHNICAL MATERIEL CORPORATION
 MAMARONECK, NEW YORK

- MACHINING NOTE**
1. LATERAL BOW OF PANEL MUST BE KEPT TO .031 TOL.
 2. MILL ALL EDGES.
 3. HOLES MUST BE DRILLED.
 4. PANEL MUST BE FREE OF ALL MACHINING MARKS, GOUGES & SCRATCH. IF NECESSARY, SAND FRONT OF PANEL WITH NO 120 GRIT SANDPAPER.

- FINISH NOTES ~**
1. S404 - YELLOW IRIDITE
 2. S114 - ZINC CHROMATE PRIMER FRONT & EDGES
 3. S115 - TMC SMOOTH GREY ENAMEL OR PRIME & PAINT TO CUSTOMER SPEC. ONLY

SYM	DESCRIPTION	DATE	CH. NO.	DRAFTS	CHECKER	ENG. APP.
A	DIM. 2 1/4 WAS 2 3/4, 1 3/64 WAS 1 13/64	7-30-62	6989	SG	WJF	VE

UNLESS OTHERWISE SPECIFIED:
 DIMENSIONS ARE IN INCHES
 TOLERANCES ON FRACTIONS ± 1/64 DECIMALS ± .005 ANGLES ± 1/2°

SCALE: HALF
 MAXIMUM ALLOWABLE TOLERANCES HAVE BEEN DETERMINED AND ANY DEVIATIONS WILL BE CAUSE FOR REJECTION.
 REMOVE ALL BURRS AND SHARP EDGES

REQ. PER UNIT	MODEL	SECTION	ASS'Y. NO.	DATE
	GPT-10K(JAC)			1-16-62

USED ON

REQ.	ITEM	PART NO.	DESCRIPTION	SYMBOL
		3/16 THK.	THE TECHNICAL MATERIEL CORP.	
		STOCK SIZE	MAMARONECK, NEW YORK	
		ALUMINUM	PANEL, FRONT	
		MATERIAL		
		2024-T3	D.A. Mann	RUZZO
		TYPE & TEMPER	DRAWN	CHECKED
		HEAT TREAT. SPEC.		FINAL APPROVAL
		SEE NOTES		MS-2840 A
		FINISH & SPEC. NO.	ELEC. DES. APP.	MECH. DES. APP.