

REQ. PER. UNIT	USED ON			MS-2479	B
	MODEL	ASS'Y. NO.	DATE		
1	GPT-40K	AX-275	11-14-60		

HOLES
A-5/16 DIA. REQ. 2

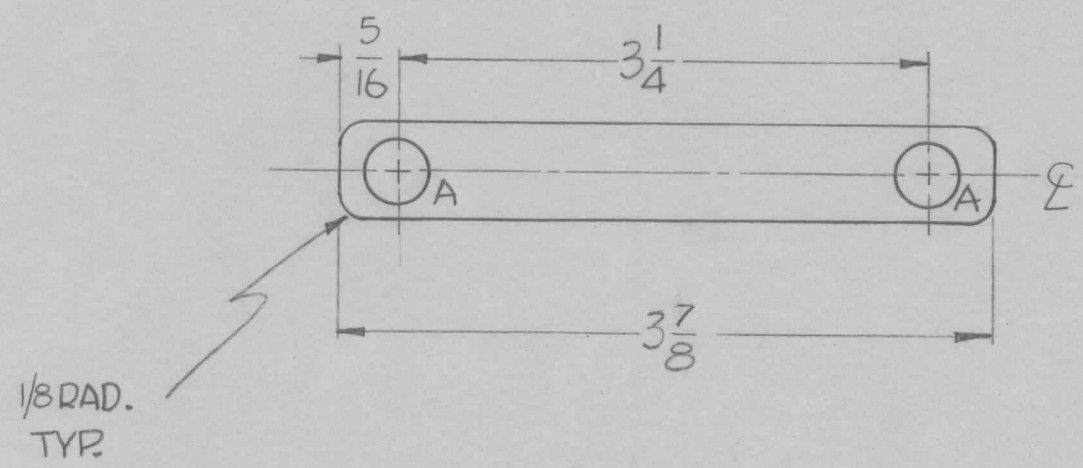

UNLESS OTHERWISE SPECIFIED DIMENSIONS ARE IN INCHES AND INCLUDE CHEMICALLY APPLIED OR PLATED FINISHES		
DECIMALS	TOLERANCES	FRACTIONS
.X ± .05		± 1/64
.XX ± .01		ANGLES
.XXX ± .005		± 0° 30'

CUT HERE
GUARANTEED
2-56

FINISH:
S245 SILVER PLATE, .0003 THK
S423 SILVER KOTE IRIDITE

REQ.	ITEM	PART NO.	DESCRIPTION				SYMBOL
		.064 THK	THE TECHNICAL MATERIEL CORP.				
		STOCK SIZE	MAMARONECK, NEW YORK				
B	1	FINISH WAS GOLD PL..000025	STRAP, ANT. TUNER INPUT				
A	1	DIM. 3 7/8 WAS 3 3/8					
ISSUE	ITEM	CHANGED FROM	DATE	CH. NO.	DRAFTS	CHECKER	ENG. APP.
TOLERANCES			SCALE:				
			MAXIMUM ALLOWABLE TOLERANCES HAVE BEEN DETERMINED AND ANY DEVIATIONS WILL BE CAUSE FOR REJECTION. REMOVE ALL BURRS AND SHARP EDGES				
TYPE & TEMPER		HEATTREAT. SPEC.	DRAWN	CHECKED	FINAL APPROVAL		
SEE NOTE					MS-2479 B		
FINISH & SPEC. NO.		ELEC. DES. APP	MECH. DES. APP				