

COLOR	COLOR CODE	STYLE	*MFGS LENS CODE
RED	1	A	.0111
GREEN	2	A	.0112
AMBER	3	A	.0113
BLUE	4	A	.0114
WHITE (TRANSLUCENT)	5	A	.0115
YELLOW	6	A	.0116
CLEAR	7	A	.0137
YELLOW, BLK. LETTER 'L'	8	B	.0376
YELLOW, BLK. LETTER 'U'	9	B	.0376

REQ. PER UNIT	USED ON		
	MODEL	ASS'Y. NO.	DATE
			LI 100 C

# STANDARD DRAWING

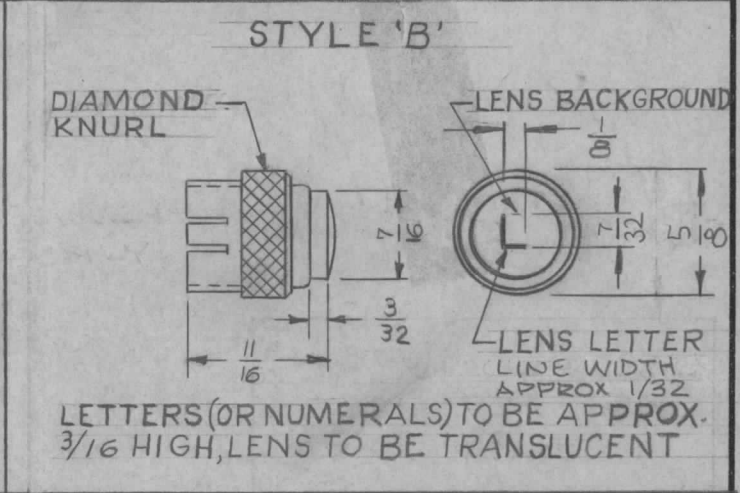
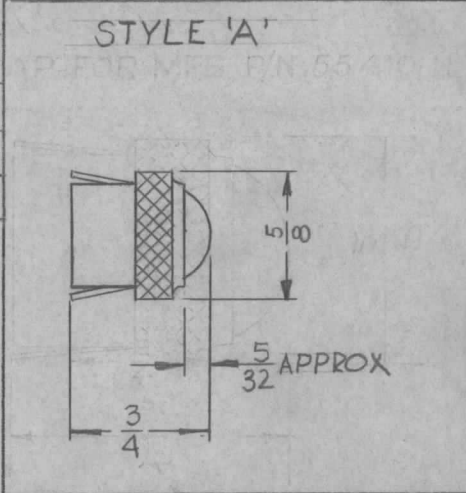

TYPE DESIGNATION TO BE IN THE FOLLOWING FORM

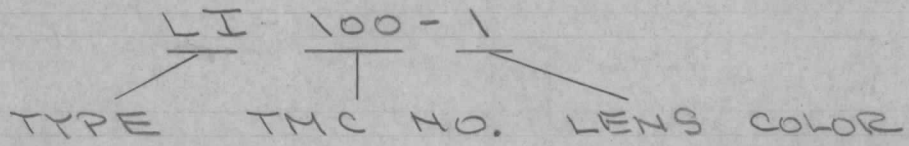

MANUFACTURERS PART NUMBER

55-\*100

— INSERT LENS CODE

NOTE:  
DIMENSIONS FOR REF ONLY

NOTE:  
THIS ITEM FOR SPARE PARTS & MAINTENANCE

ISSUE	ITEM	CHANGED FROM	DATE	CH. NO.	DRAFTS	CHECKER	ENG. APP.
C		DEWG REVISED	5-9-66	16224	WH	JCB	JCB
B	3	S-401-153 ADDED; DIAL CO. DELETED; STYLE 'B' ADDED; STYLE COLUMN ADDED; CODE B & 9 ADDED; 55410-11 WAS 87410-11	4/27/64	11293	A.M.	@	JCB
A	1	METAL FINISH W.H. NICKEL ADDED	5-27-63	2368	WH	JCB	JCB

TOLERANCES                      SCALE: S401-153

DEC. DIM. ±                      MAXIMUM ALLOWABLE TOLERANCES HAVE BEEN DETERMINED AND ANY DEVIATIONS WILL BE CAUSE FOR REJECTION.

FRAC. DIM. ±                      REMOVE ALL BURRS AND SHARP EDGES

ANGULAR DIM. ±

REQ. ITEM	PART NO.	DESCRIPTION	SYMBOL
		THE TECHNICAL MATERIEL CORP. MAMARONECK, NEW YORK	
	STOCK SIZE	CAP, LENS	
	MATERIAL	P/O TS 106	
		DRAWN                      CHECKED                      FINAL APPROVAL	
	TYPE & TEMPER    HEAT TREAT. SPEC.		
	METAL: WHITE NICKEL		LI 100 C
	FINISH & SPEC. NO.	ELEC. DES. APP.    MECH. DES. APP.	