

REVISIONS									
ZONE	SYM	DESCRIPTION	DATE	E.M.N. NO.	DRAFT	CHKD	APPD		
+	X	EXPER. RELEASE	4-14-44	1					
+	XI	SEE SHEET 2 OF 2, REVISION "XI"	5-19-44	2					
+		ORIGINAL RELEASE FOR PRODUCTION	11-17-45						
U443	A	CH. A+B DIM. WAS 2 7/16	7-20-44	16593					

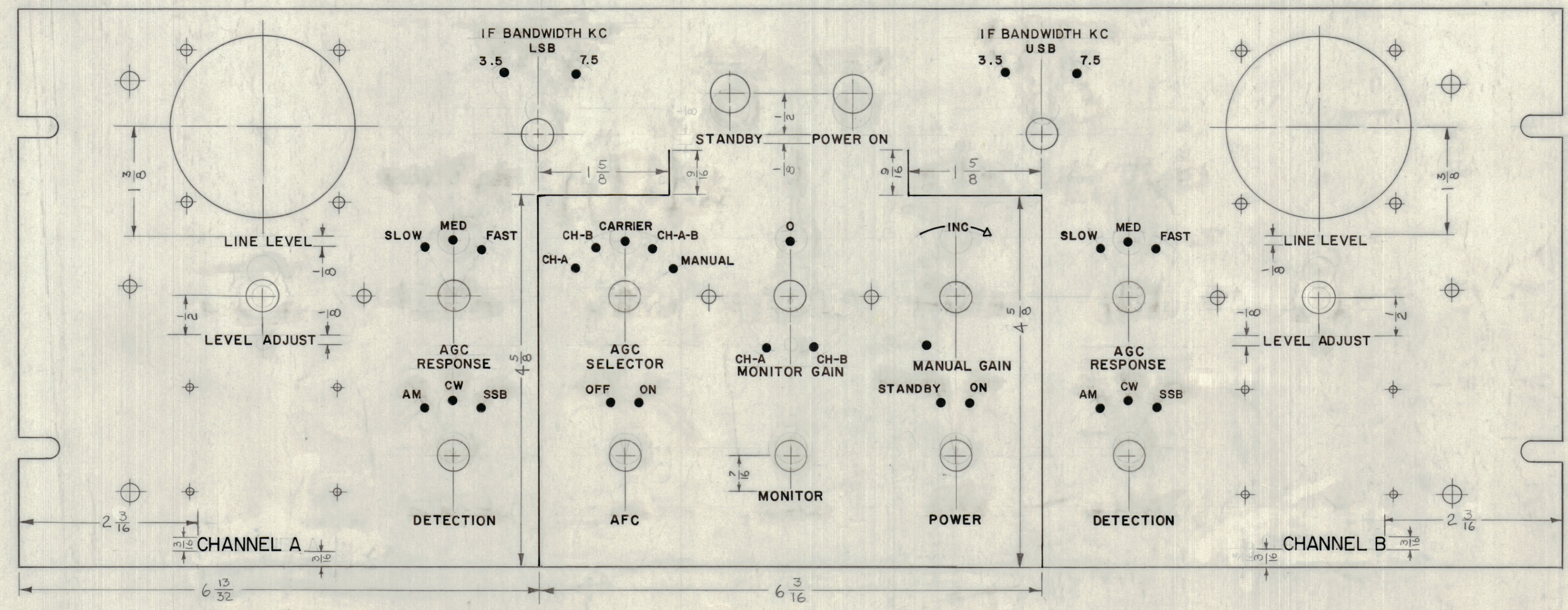

UNLESS OTHERWISE SPECIFIED:
 1-ALL ENGRAVING TO BE 3/32 WHITE FILLED GOTHIC
 2-ALL DOTS TO BE WHITE FILLED
 3-ALL LINES TO BE WHITE FILLED
 4-ALL ARROWHEADS 3/32 X 5/32 WHITE OUTLINED FILLED

LETTER HEIGHT	DEPTH OF STROKE	WIDTH OF STROKE
3/32	.010	.015
1/8	.010	.020
3/16	.010	.025
DOTS	.010	1/16 DIA.
LINES	.010	.015
ARROWHEADS	.010	

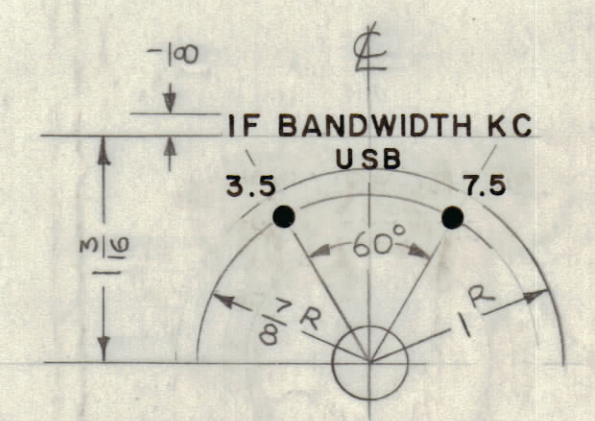
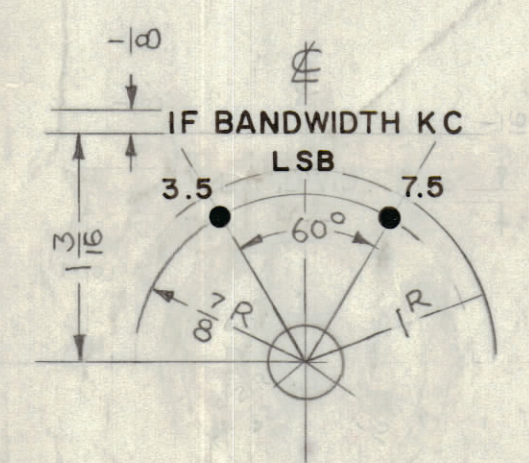
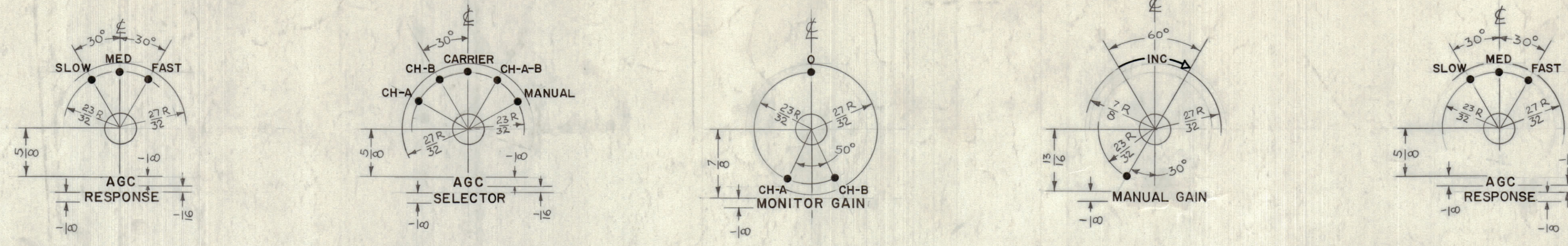
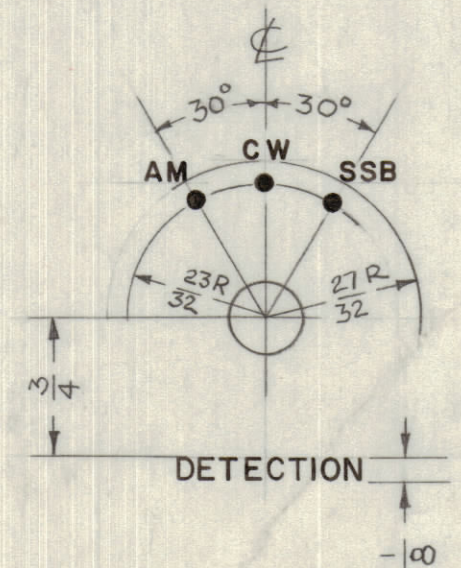
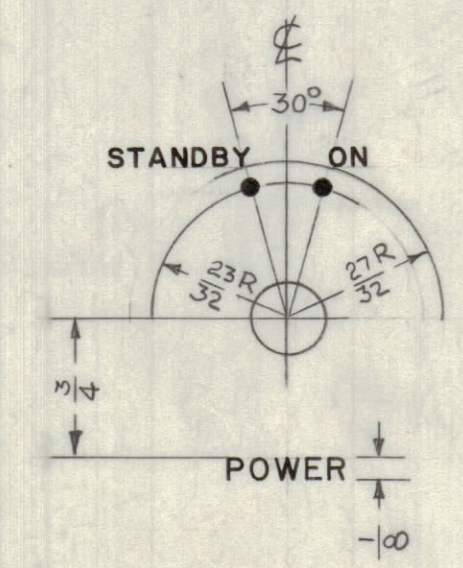
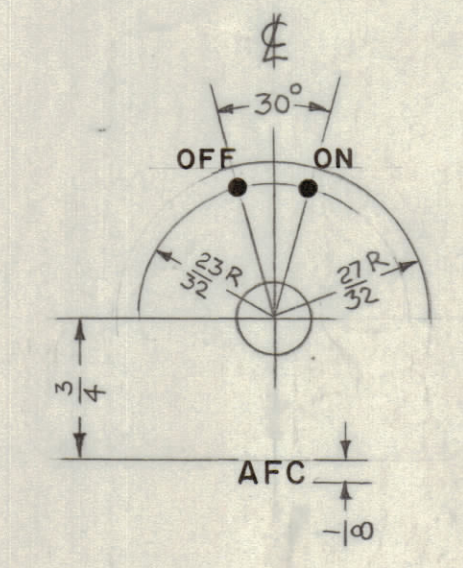
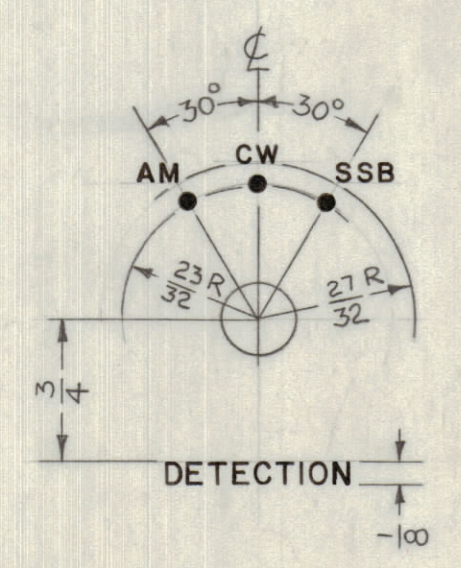

NOTES

QTY./UNIT	MODEL USED ON	ASSY. NO.
SCALE	CODE	
1:1	A	

REF: M5 3746 (B)	
REQ'D. ITEM	PART NUMBER
O. POSE LIST OF MATERIAL	
MATERIAL	THE TECHNICAL MATERIEL CORP. MAMARONECK, NEW YORK
FINISH	TITLE MARKING, PANEL, FRONT MARKING METHOD, ENGRAVING
UNLESS OTHERWISE SPECIFIED DIMENSIONS ARE IN INCHES AND INCLUDE CHEMICALLY APPLIED OR PLATED FINISHES	DRAWN DATE CHECKED DATE ELECT. DES. DATE MECH. DES. DATE
DECIMALS X ± .08 XX ± .01 XXX ± .005	FRACTIONS ± 1/64 ANGLES ± 0° 30'
DATE DATE DATE DATE	
SHEET 1 OF 2	

LD-1489 A

REVISIONS							
ZONE	SYM	DESCRIPTION	DATE	E.M.N. NO.	DRAFT	CHKD	APPD
X		EXPER. RELEASE	4-14-64	1			
X I		R6245 & R6246 ADDED; S6211 WAS S6203; S6212 WAS S6204	5-18-64	2			
Ø		ORIGINAL RELEASE FOR PRODUCTION	11-17-65				
A		SEE SHEET 1 OF 2	7-20-66	16593			

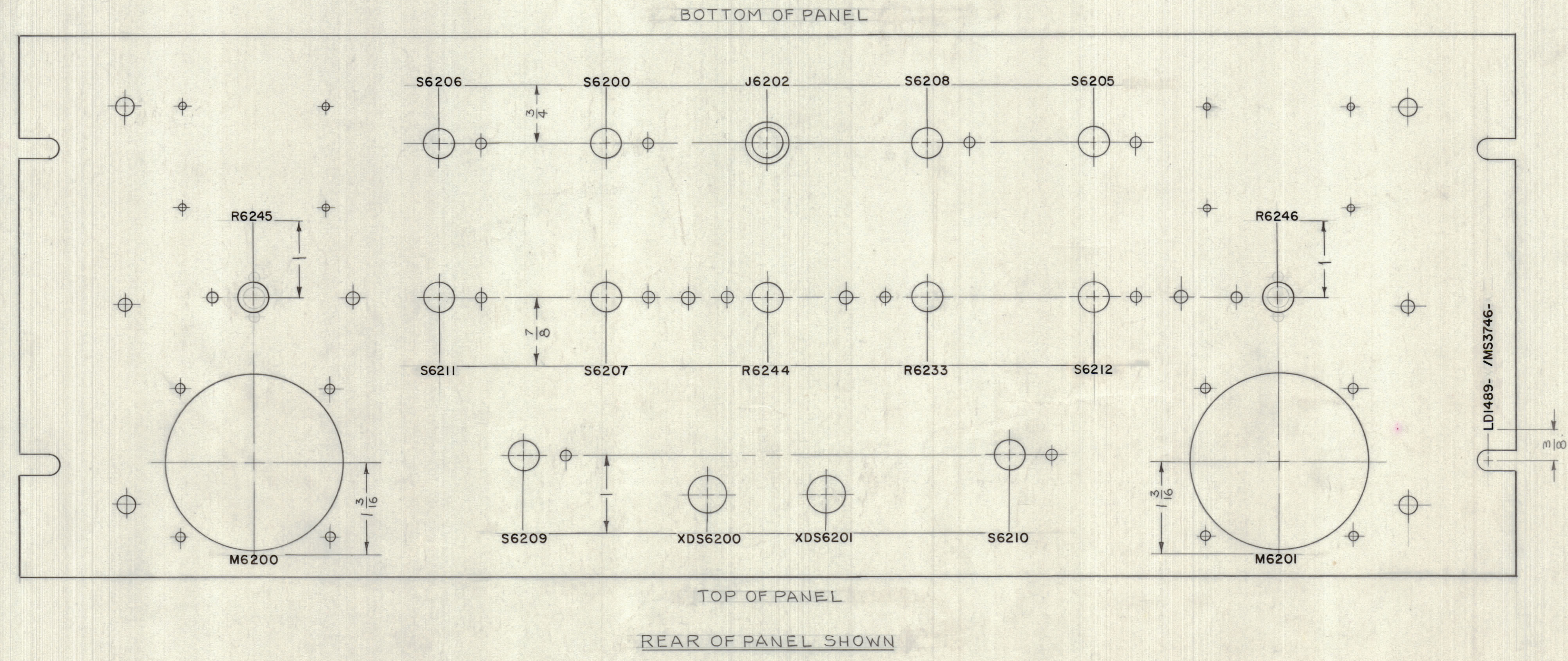

MARKING PROCESS: AS PER TMC SPECIFICATION S-727

NOTE:
 MARKING PROCESS: AS PER TMC SPECIFICATION S-727.
 LETTERING: 1/8 HIGH BLACK GOTHIC, LOCATED AS SHOWN.
 MARK TMC PART NO. WITH LATEST REVISION LETTERS, 1/8 HIGH BLACK GOTHIC.

REF: MS-3746 (e)

QTY./UNIT	MODEL USED ON	ASBY. NO.
1	SBS-7	
SCALE	CODE	
1:1	A	

REQ'D.	ITEM	PART NUMBER	DESCRIPTION	SYMBOL
O POSE LIST OF MATERIAL				
MATERIAL		THE TECHNICAL MATERIEL CORP. MAMARONECK, NEW YORK		
FINISH		TITLE MARKING, PANEL, FRONT MARKING METHOD: AS PER TMC S-727		
UNLESS OTHERWISE SPECIFIED DIMENSIONS ARE IN INCHES AND INCLUDE CHEMICALLY APPLIED OR PLATED FINISHES		DRAWN	DATE	FINAL APPROVAL
DECIMALS ± .05 FRACTIONS ± 1/64 ANGLES ± 0° 30'		DATE	DATE	DATE
TOLERANCES		ELECT. DES.	DATE	DATE
		MECH. DES.	DATE	DATE
		LD 1489		A
		SHEET 2 OF 2		REV. LTR.

NOTES

LD 1489 A