

LD-1456 0

REVISIONS

SYM	DESCRIPTION	DATE	E.M.N. NO.	DRAFT	CHKD	APPD
0	ORIGINAL RELEASE FOR PRODUCTION	5/26/64	0	A.M.		

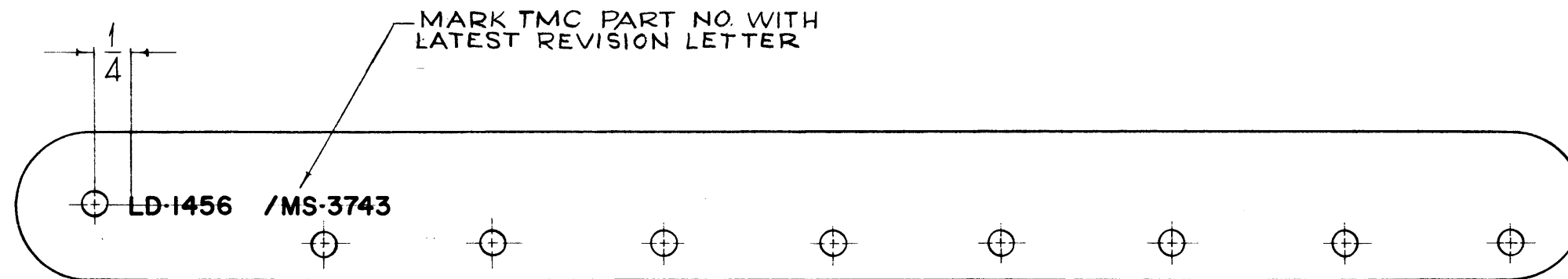
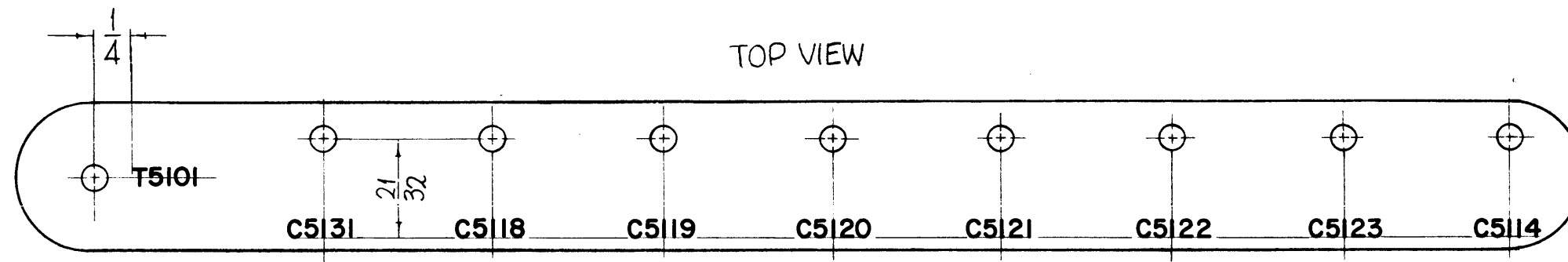

REF-TMC DWG. NO. MS-3743

MARKING PROCESS: AS PER TMC SPECIFICATION S-727.
LETTERING: 1/8 HIGH BLACK GOTHIC, LOCATED AS SHOWN.

1	GPT-200K	AX-394
Q'TY./UNIT	MODEL USED ON	ASS'Y. NO.
#	A	

THE CONTENTS OF THIS DRAWING ARE THE EXCLUSIVE PROPERTY OF THE TECHNICAL MATERIEL CORP. ITS UNAUTHORIZED USE OR REPRODUCTION IN WHOLE OR IN PART IS STRICTLY FORBIDDEN.

REQ'D.	ITEM	PART NUMBER	DESCRIPTION	SYMBOL
F. BUDETTI LIST OF MATERIAL				
MATERIAL		THE TECHNICAL MATERIEL CORP. MAMARONECK, NEW YORK		
FINISH		TITLE MARKING, GROUND STRAP MARKING METHOD: AS PER TMC SPEC. S-727		
UNLESS OTHERWISE SPECIFIED DIMENSIONS ARE IN INCHES AND INCLUDE CHEMICALLY APPLIED OR PLATED FINISHES		DRAWN John C Biele CHECKED aa ELECT. DES. JCB MECH. DES. JCB	DATE 4/22/64 DATE 4/13/64	FINAL APPROVAL RJC DATE SHEET LD-1456 0 REV. LTR.
DECIMALS .X ± .05 .XX ± .01 .XXX ± .05	TOLERANCES	FRACTIONS ± 1/64 ANGLES ± 0° 30'		

NOTES