

GR 208 A

REVISIONS					
SYM	DESCRIPTION	DATE	E.M.N. NO.	DRAFT	CHKD APPD
X	EXPERIMENTAL RELEASE	4-11-64		<i>[Signature]</i>	
Ø	ORIGINAL RELEASE FOR PRODUCTION	9-14-64	Ø	qe	
A	3/8 REF ADDED, 11/16 WAS 1/2 OVERALL 2 7/32 WAS 2 5/8, STAMPING NOTE DELETED	11.1.66	17120	lyw	<i>[Signature]</i>

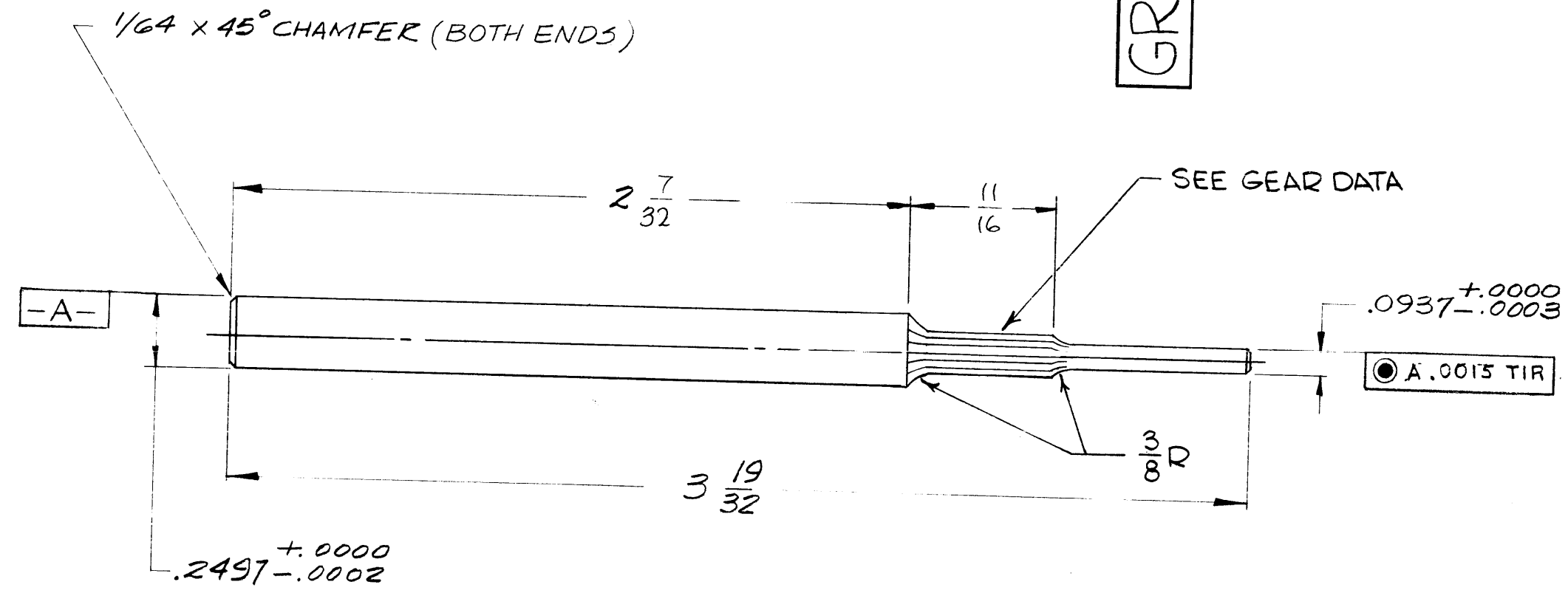

GEAR DATA	
PITCH	80
NO OF TEETH	10
PITCH DIA	.1250
P.A.	20°

Q'TY./UNIT	MODEL USED ON	ASS'Y. NO.
1	HFR-2	A3625
1	HFR-2	A3624
SCALE	CODE	
NONE	A	

NOTES

THE CONTENTS OF THIS DRAWING ARE THE EXCLUSIVE PROPERTY OF THE TECHNICAL MATERIEL CORP. ITS UNAUTHORIZED USE OR REPRODUCTION IN WHOLE OR IN PART IS STRICTLY FORBIDDEN.

REQ'D.	ITEM	PART NUMBER	DESCRIPTION	SYMBOL
T. KRUY	E 3112B	LIST OF MATERIAL		
MATERIAL		THE TECHNICAL MATERIEL CORP. MAMARONECK, NEW YORK		
#303 STAINLESS STEEL		TITLE		
FINISH		GEAR SHAFT, SPUR		
S104 PASSIVATE		DRAWN <i>[Signature]</i> DATE 4-11-64		
UNLESS OTHERWISE SPECIFIED DIMENSIONS ARE IN INCHES AND INCLUDE CHEMICALLY APPLIED OR PLATED FINISHES		CHECKED <i>[Signature]</i> DATE 9-11-64		
DECIMALS .X ± .05 .XX ± .01 .XXX ± .005		ELECT. DES. DATE		
FRACTIONS ± 1/64 ANGLES ± 0° 30'		MECH. DES. DATE		
TOLERANCES		FINAL APPROVAL <i>[Signature]</i> DATE		
		SHEET		
		GR 208		
		REV. LTR. A		