

| REVISIONS |     |                         |         |          |       |      |
|-----------|-----|-------------------------|---------|----------|-------|------|
| ZONE      | LTR | DESCRIPTION             | DATE    | E.M.N.NO | DRAFT | CHKD |
|           | Ø   | ORIG. RELEASE FOR PROD. | 5.15.68 |          |       |      |

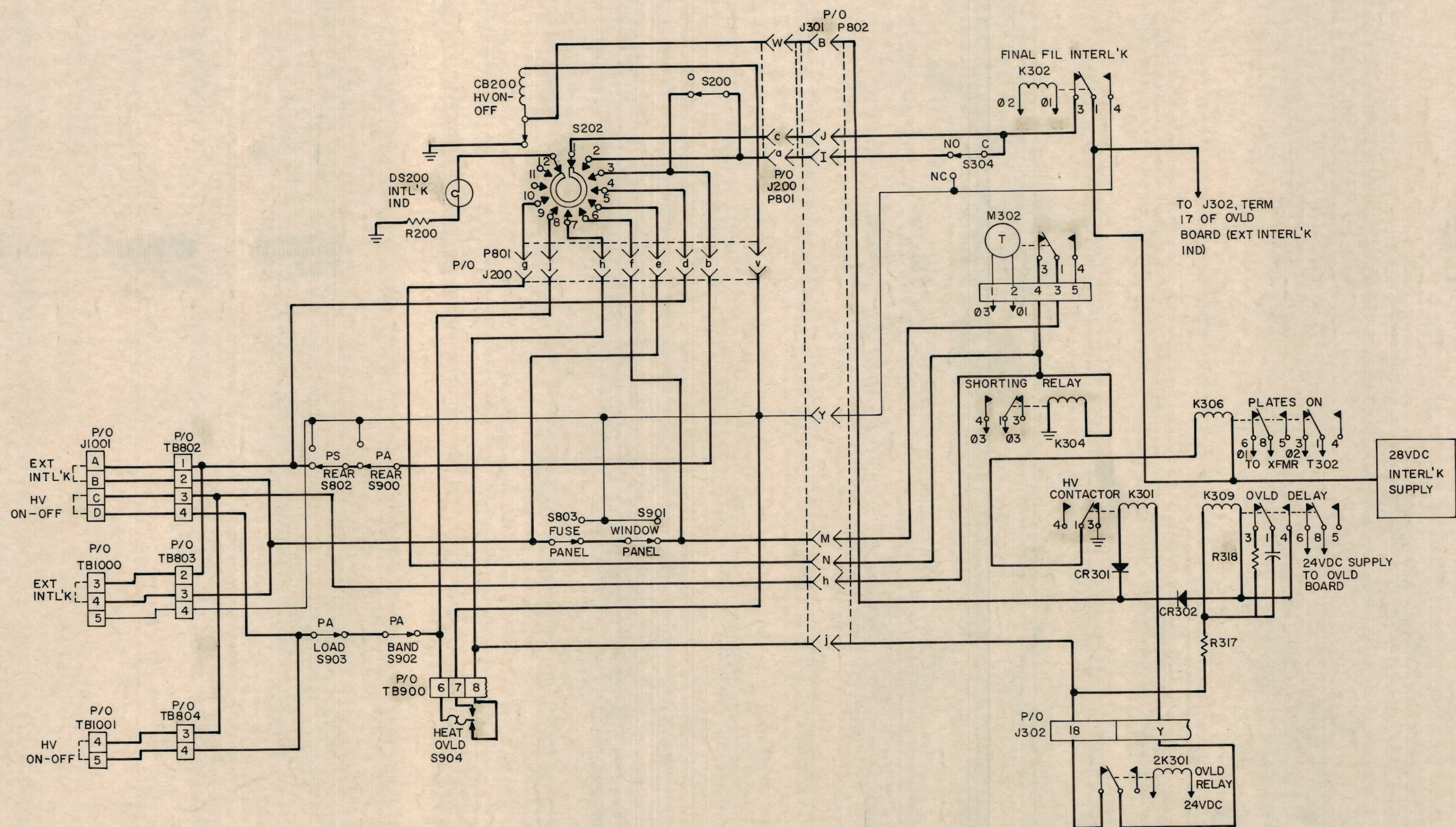

| QTY. REQ.        | ITEM | PART NO.                     | DESCRIPTION | SYMBOL   |
|------------------|------|------------------------------|-------------|----------|
| LIST OF MATERIAL |      |                              |             |          |
| FINAL APPROVAL   |      | DATE                         |             |          |
| MECH. DES.       |      | DATE                         |             |          |
| ELECT. DES.      |      | DATE                         |             |          |
| CHECKED          |      | DATE                         |             |          |
| DRAWN            |      | DATE                         |             |          |
| MATERIAL         |      | SIZE CODE IDENT. NO. DWG NO. |             | ISSUE    |
| FINISH           |      | D 82679 CK 1499              |             | Ø        |
| SCALE            |      |                              |             | SHEET OF |

UNLESS OTHERWISE SPECIFIED DIMENSIONS ARE IN INCHES AND INCLUDE CHEMICALLY APPLIED OR PLATED FINISHES

TOLERANCES ON  
 DECIMALS .X ± .05  
 .XX ± .01  
 .XXX ± .005  
 FRACTIONS ± 1/64  
 ANGLES ± 0° -30'

| QTY / UNIT  | MODEL USED ON | ASS'Y NO. |
|---|---------------|-----------|
| APPLICATION   |               |           |
| CODE  |               |           |
| NOTICE TO PERSONS RECEIVING THIS DRAWING  |               |           |
| THE TECHNICAL MATERIEL CORPORATION claims proprietary right in the material disclosed herein. This drawing is issued in confidence for engineering information only and may not be reproduced or used to manufacture anything shown hereon without permission from THE TECHNICAL MATERIEL CORPORATION to the user. This drawing is loaned for mutual assistance and is subject to recall at any time. |               |           |