

REQ. PER UNIT		USED ON	
1	LSP-8	ASSY. NO.	DATE
1	LSP-8A		1/5/66
			4/12/66

CK1087 A

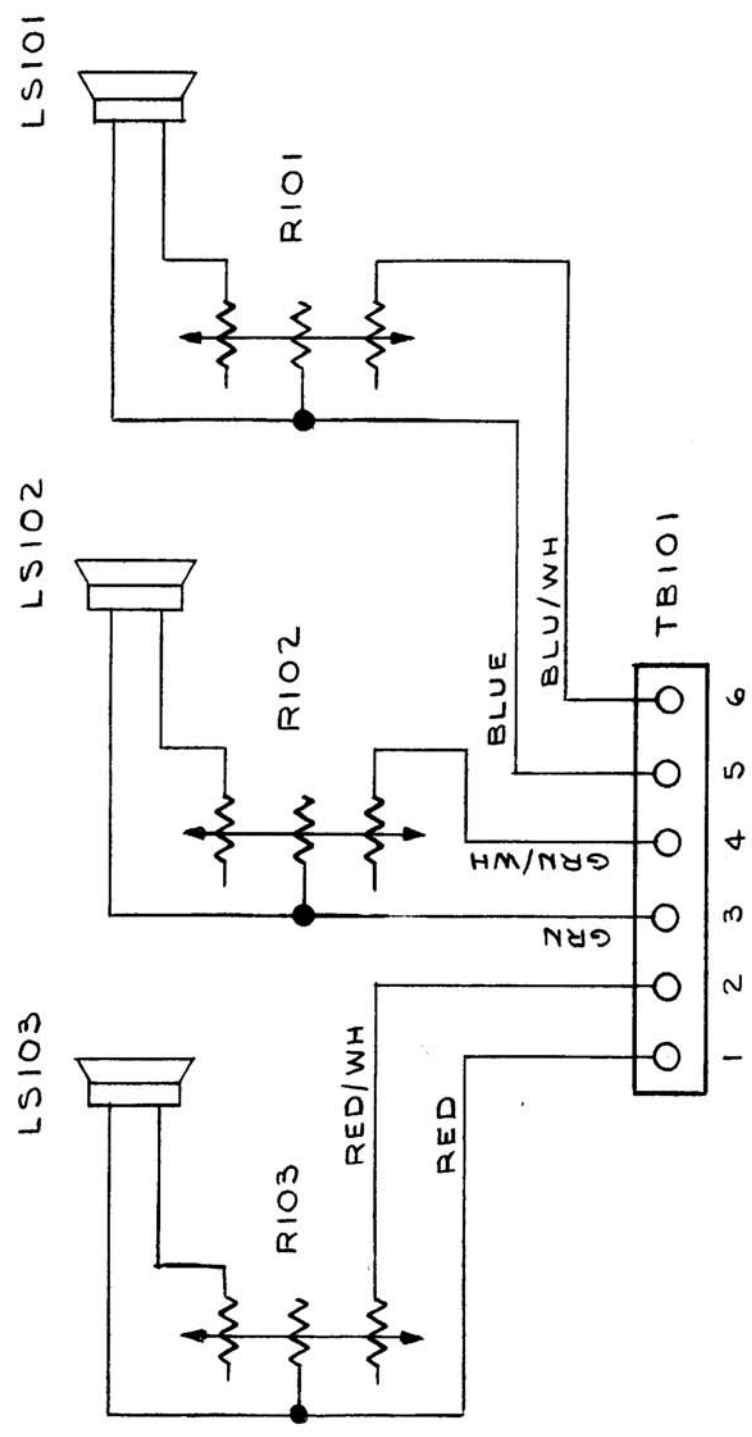

REQ. ITEM	PART NO.	DESCRIPTION		SYMBOL
		R. HAY		
STOCK SIZE		THE TECHNICAL MATERIEL CORP. MAMARONECK, NEW YORK		
MATERIAL		DIAGRAM, SCHEMATIC		
TYPE & TEMPER		LSP-8		
HEAT TREAT. SPEC.		JL	4/5/66	
FINISH & SPEC. NO.		DRAWN	CHECKED	
ELEC. DES. APP.		FINAL APPROVAL		
MECH. DES. APP.		CK1087A		

DESCRIPTION	DATE	CH. NO.	DRAFTS	CHECKER	ENG. APP.
A Add LSP-8A (Model)	5/4/66	C.C	C.V	<i>[Signature]</i>	<i>[Signature]</i>
ORIGINAL RELEASE	1/6/66			<i>[Signature]</i>	

UNLESS OTHERWISE SPECIFIED	SCALE	CODE
DIMENSIONS ARE IN INCHES AND INCLUDE		
CHEMICALLY APPLIED OR PLATED FINISHES		
DECIMALS	FRACTIONS	
.X ± .05	± 1/64	
.XX ± .01	ANGLES	
.XXX ± .005	± 0° 30'	