

CK1025 C

REVISIONS					
SYM	DESCRIPTION	DATE	E.M.N. NO.	DRAFT	CHKD APPD
X1	E1508, E1509 RELOCATED	8-31-65	H	E	
Ø	ORIGINAL RELEASE FOR PROD	8/31	Ø	FLO	
A	W1501 THRU. W1511 ADDED	12-26-65	15000	AVV	AVV
B	C1501, C1502, C1503, W1512, W1513, W1514 ADDED	12-28-65	15406	C.D.L	C.D.L
C	MODEL USED ON HYRB-2 DELETED	4-22-66	CC	AVV	AVV

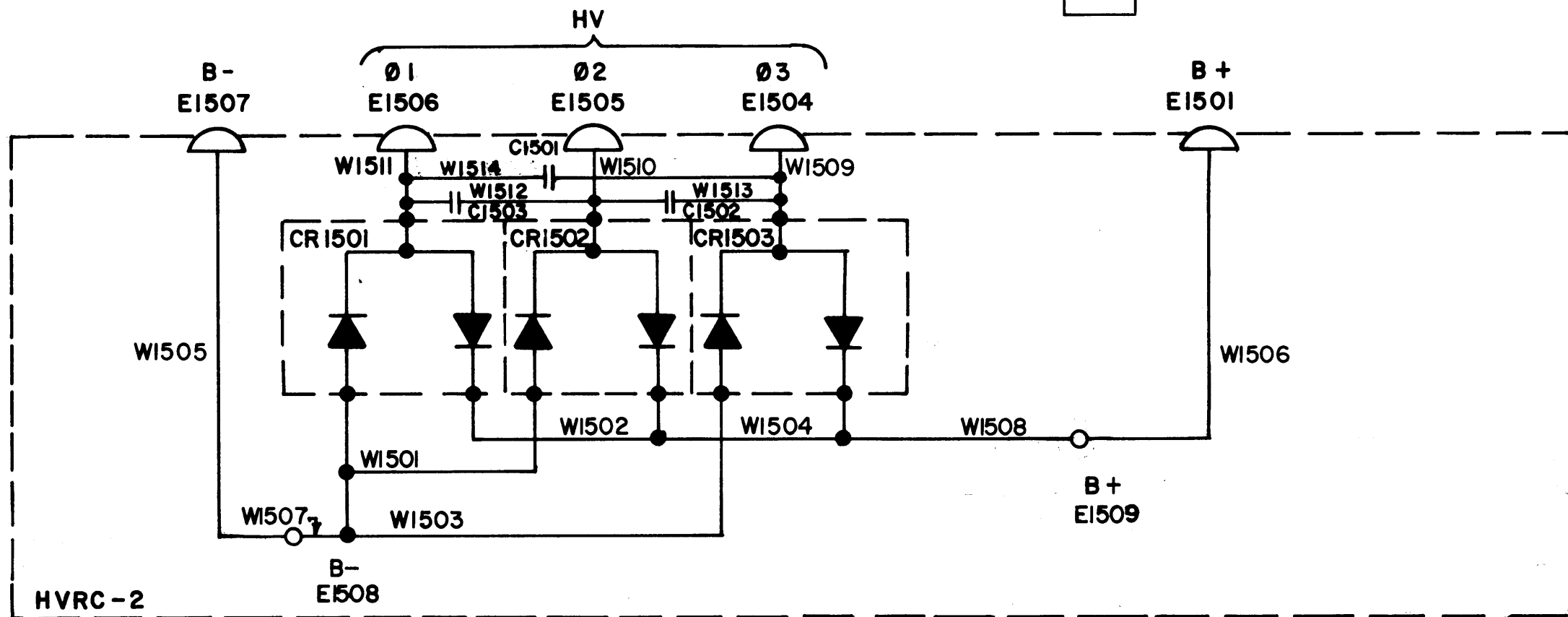

LAST SYMBOLS
 E1508
 CR1503
 W1514
 C1503

MISSING SYMBOLS
 E1502
 E1503

1			HVRC - 2		
Q'TY./UNIT	MODEL USED ON		ASS'Y. NO.		
SCALE	CODE				
	A				

THE CONTENTS OF THIS DRAWING ARE THE EXCLUSIVE PROPERTY OF THE TECHNICAL MATERIEL CORP. ITS UNAUTHORIZED USE OR REPRODUCTION IN WHOLE OR IN PART IS STRICTLY FORBIDDEN.

REQ'D.	ITEM	PART NUMBER	DESCRIPTION	SYMBOL
F. BUDETTI				
MATERIAL			THE TECHNICAL MATERIEL CORP. MAMARONECK, NEW YORK	
FINISH			TITLE WIRING SCHEMATIC DIAGRAM	
UNLESS OTHERWISE SPECIFIED DIMENSIONS ARE IN INCHES AND INCLUDE CHEMICALLY APPLIED OR PLATED FINISHES				
DECIMALS	TOLERANCES		FRACTIONS	
.X ± .05			± 1/64	
.XX ± .01			ANGLES	
.XXX ± .005			± 0 30'	
DRAWN	G.D.L	DATE	8-13-65	FINAL APPROV
CHECKED	AVV	DATE	8/31/65	DATE
ELECT. DES.		DATE		8/31/65
MECH. DES.		DATE		CK1025
SHEET				REV. LTR.
				C

NOTES