

AX-448 A

|               |                 |
|---------------|-----------------|
| REQ. PER UNIT | 2               |
| MODEL         | GPT-200K AS-123 |
| ABBY. NO.     | AX-446          |
| DATE          | 10-23-63        |

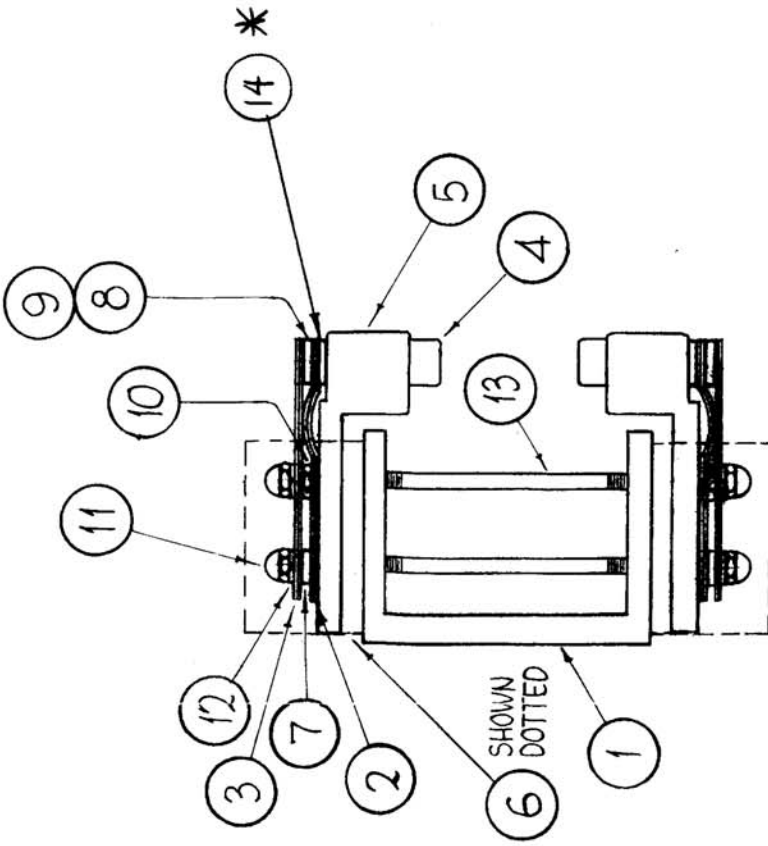

\* MORE THAN 24, (IT.14) MAY BE USED AS REQ'D.

| REQ. ITEM | PART NO. | DESCRIPTION                    | SYMBOL |
|-----------|----------|--------------------------------|--------|
| 24        | 14       | WASHER, FLAT                   |        |
| 6         | 13       | STUD, THREADED                 |        |
| 12        | 12       | LOCKWASHER, SPLIT              |        |
| 12        | 11       | NUT, CAP                       |        |
| 6         | 10       | NUT, HEXAGON                   |        |
| 6         | 9        | SCREW, MACHINE, FLATHEAD       |        |
| 6         | 8        | SPACER                         |        |
| 2         | 7        | CONTACT HOLDER                 |        |
| 2         | 6        | INSULATOR, TEFLON              |        |
| 2         | 5        | CONTACT HOLDER                 |        |
| 6         | 4        | SLUG, CONTACT, BANDSWITCH      |        |
| 12        | 3        | SPRING, PRESSURE               |        |
| 12        | 2        | CONTACT, BANDSWITCH            |        |
| 1         | 1        | 'U' BRACKET, CONTACT & LEG MTG |        |
|           |          | F. BUDETTI                     |        |

THE TECHNICAL MATERIEL CORP.  
MAMARONECK, NEW YORK

CONTACT ASSY

|                    |                    |                  |     |
|--------------------|--------------------|------------------|-----|
| John C. Biele      | QA                 | EB               | RRC |
| Drawn              | Checked            | Final Appr. Val. |     |
| <i>[Signature]</i> | <i>[Signature]</i> | AX-448 A         |     |
| ELEC. DES. APP.    | MECH. DES. APP.    | MECH. DES. APP.  |     |

|                                                                                                       |                                                      |          |         |        |         |           |                 |  |  |
|-------------------------------------------------------------------------------------------------------|------------------------------------------------------|----------|---------|--------|---------|-----------|-----------------|--|--|
| A                                                                                                     | IT. 14 & * NOTE ADDED                                | 4-22-65  | 13899   | J.P.   | J.C.B.  |           |                 |  |  |
| O                                                                                                     | ORIGINAL RELEASE                                     | 5-16-64  |         | A.S.B. |         |           |                 |  |  |
| X2                                                                                                    | ITEM 7 (PX-769) DELETED<br>ITEM 14 CHANGED TO ITEM 7 | 2-3-64   |         |        |         |           |                 |  |  |
| X1                                                                                                    | ITEM 13 WAS SM-156-7                                 | 10-30-63 |         |        |         |           |                 |  |  |
| SYM                                                                                                   | DESCRIPTION                                          | DATE     | CH. NO. | DRAFTS | CHECKER | ENG. APP. | SCALE 1/2" = 1" |  |  |
| UNLESS OTHERWISE SPECIFIED DIMENSIONS ARE IN INCHES AND INCLUDE CHEMICALLY APPLIED OR PLATED FINISHES |                                                      |          |         |        |         |           | CODE            |  |  |
| TOLERANCES                                                                                            |                                                      |          |         |        |         |           | FRACTIONS       |  |  |
| .X ± .05                                                                                              |                                                      |          |         |        |         |           | ± 1/64          |  |  |
| .XX ± .01                                                                                             |                                                      |          |         |        |         |           | ANGLES          |  |  |
| .XXX ± .005                                                                                           |                                                      |          |         |        |         |           | ± 0° 30'        |  |  |