

AX-301 B

THE CONTENTS OF THIS DRAWING ARE THE EXCLUSIVE PROPERTY OF THE TECHNICAL MATERIEL CORP. ITS UNAUTHORIZED USE OR REPRODUCTION IN WHOLE OR IN PART IS STRICTLY FORBIDDEN.

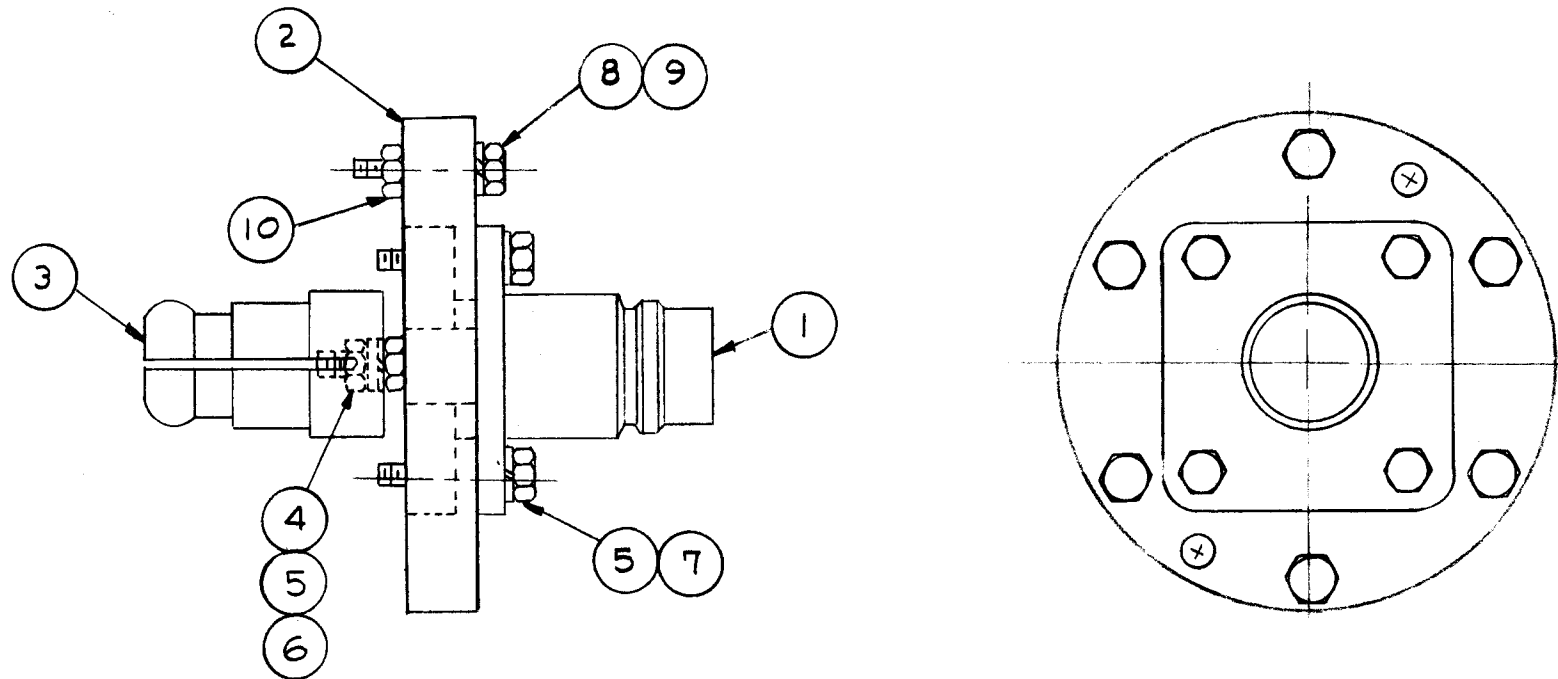

NOTICE TO PERSONS RECEIVING THIS DRAWING
 THE TECHNICAL MATERIEL CORPORATION claims proprietary right in the material disclosed hereon. This drawing is issued in confidence for engineering information only and may not be reproduced or used to manufacture anything shown hereon without permission from THE TECHNICAL MATERIEL CORPORATION to the user. This drawing is loaned for mutual assistance and is subject to recall at any time.

Property of:
 THE TECHNICAL MATERIEL CORPORATION
 MAMARONECK, NEW YORK

6	10	NTH3118BN16	NUT, HEX	
6	9	LWS31MRN	LOCKWASHER, SPLIT	
6	8	SCHH3118BN32	BOLT MACHINE	
4	7	SCHH2520BN8	BOLT MACHINE	
1	6	NTH2528BN14	NUT, HEX	
5	5	LWS25MRN	LOCKWASHER, SPLIT	
1	4	FW25HBN	WASHER, FLAT	
1	3	PO-203-70	CONNECTOR, INNER TO OHM	
1	2	PM-722	ADAPTER 3 1/8 EIA	
1	1	JJ-225	CONNECTOR, RECEPTACLE QDL	

REQ.	ITEM	PART NO.	DESCRIPTION	SYMBOL
STOCK SIZE			THE TECHNICAL MATERIEL CORP. MAMARONECK, NEW YORK	
MATERIAL			ASSEMBLY, ADAPTER, QDL 70 OHM	
TYPE & TEMPER		HEAT TREAT. SPEC.	DRAWN	CHECKED
FINISH & SPEC. NO.		ELEC. DES. APP.	MECH. DES. APP.	AX-301 B

B	REDRAWN & REVISED FROM @ SIZE	12-12-61	596	E.A.	AK	DB
SYM	DESCRIPTION	DATE	CH. NO.	DRAFTS	CHECKER	ENG. APP.
UNLESS OTHERWISE SPECIFIED: DIMENSIONS ARE IN INCHES TOLERANCES ON FRACTIONS ± 1/64 DECIMALS ± .005 ANGLES ± 1/2°		SCALE: MAXIMUM ALLOWABLE TOLERANCES HAVE BEEN DETERMINED AND ANY DEVIATIONS WILL BE CAUSE FOR REJECTION. REMOVE ALL BURRS AND SHARP EDGES				
REQ. PER UNIT		MODEL		SECTION	ASS'Y. NO.	DATE
		USED ON				