

REVISIONS							
E.M.N. NO.	DRAFT	CHKD	ZONE	LTR	DESCRIPTION	DATE	APPROVED
	BA	~		Ø	ORIGINAL RELEASE FOR PRODUCTION	1-14-81	

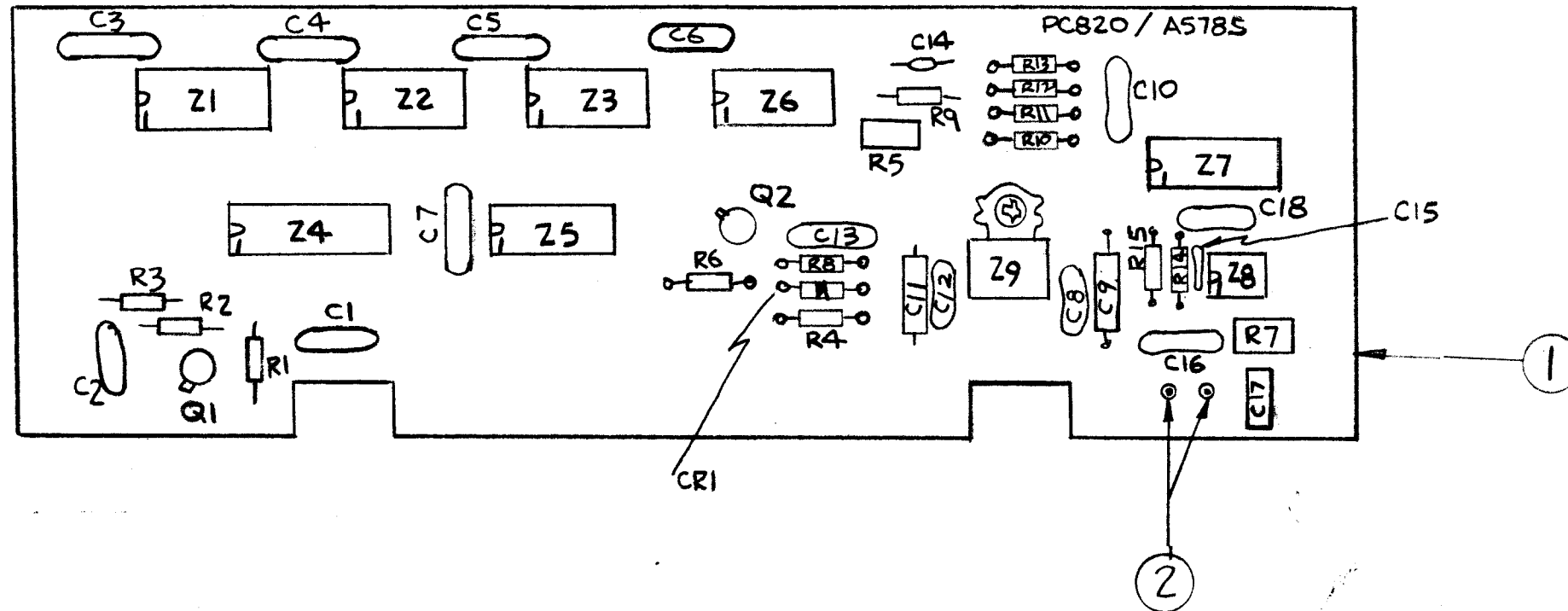

ASSEMBLY NOTES

1. TO MOUNT COMPONENTS INSERT LEADS THROUGH HOLES.
2. CAUTION, WHEN APPLYING HEAT & SOLDER TO LEAD & FOIL.
3. CLEAN & INSPECT AS PER SPEC S676.
4. FOR ELECTRICAL COMPONENT PART NUMBERS REFER TO NPL A5784
5. USE SYMBOL NUMBERS FOR ASSY. REF.

REQ'D	ITEM	PART NUMBER	DESCRIPTION	SYM.
X	3	BS100	SOLDER SOFT	
2	2		PIN, CONNECTOR	
1	1	PCB20	PRINTED CIRCUIT Bd	

LIST OF MATERIAL

1	GRR-110C	Z107	UNLESS OTHERWISE SPECIFIED DIMENSIONS ARE IN INCHES AND INCLUDE CHEMICALLY APPLIED OR PLATED FINISHES	FINAL APPROVAL	DATE	THE TECHNICAL MATERIEL CORP. MAMARONECK, NEW YORK ASSEMBLY DIAGRAM 1 MHz SYNTHESIZER						
QTY / UNIT	MODEL USED ON	ASS'Y NO.	DECIMALS .X ± .05 .XX ± .01 .XXX ± .005	MECH. DES.	DATE				SIZE	CODE IDENT. NO.	DWG NO.	ISSUE
APPLICATION			FRACTIONS 1/64 ANGLES 0° - 30'	ELECT. DES.	DATE				B	82679	A5785	Ø
CODE			MATERIAL	CHECKED	DATE				SCALE		SHEET	OF
NOTICE TO PERSONS RECEIVING THIS DRAWING THE TECHNICAL MATERIEL CORPORATION claims proprietary right in the material disclosed hereon. This drawing is issued in confidence for engineering information only and may not be reproduced or used to manufacture anything shown hereon without permission from THE TECHNICAL MATERIEL CORPORATION to the user. This drawing is loaned for mutual assistance and is subject to recall at any time.			FINISH	DRAWN	DATE							