

APPLICATION			REVISIONS						
QTY	MODEL USED ON	ASS'Y NO.	LTR	DESCRIPTION	DATE	E.M.N.NO	DRAFT	CHKD	APPD
1	GPTR 10K ()	AF109	Ø	ORIGINAL RELEASE	5/3/73		CS		

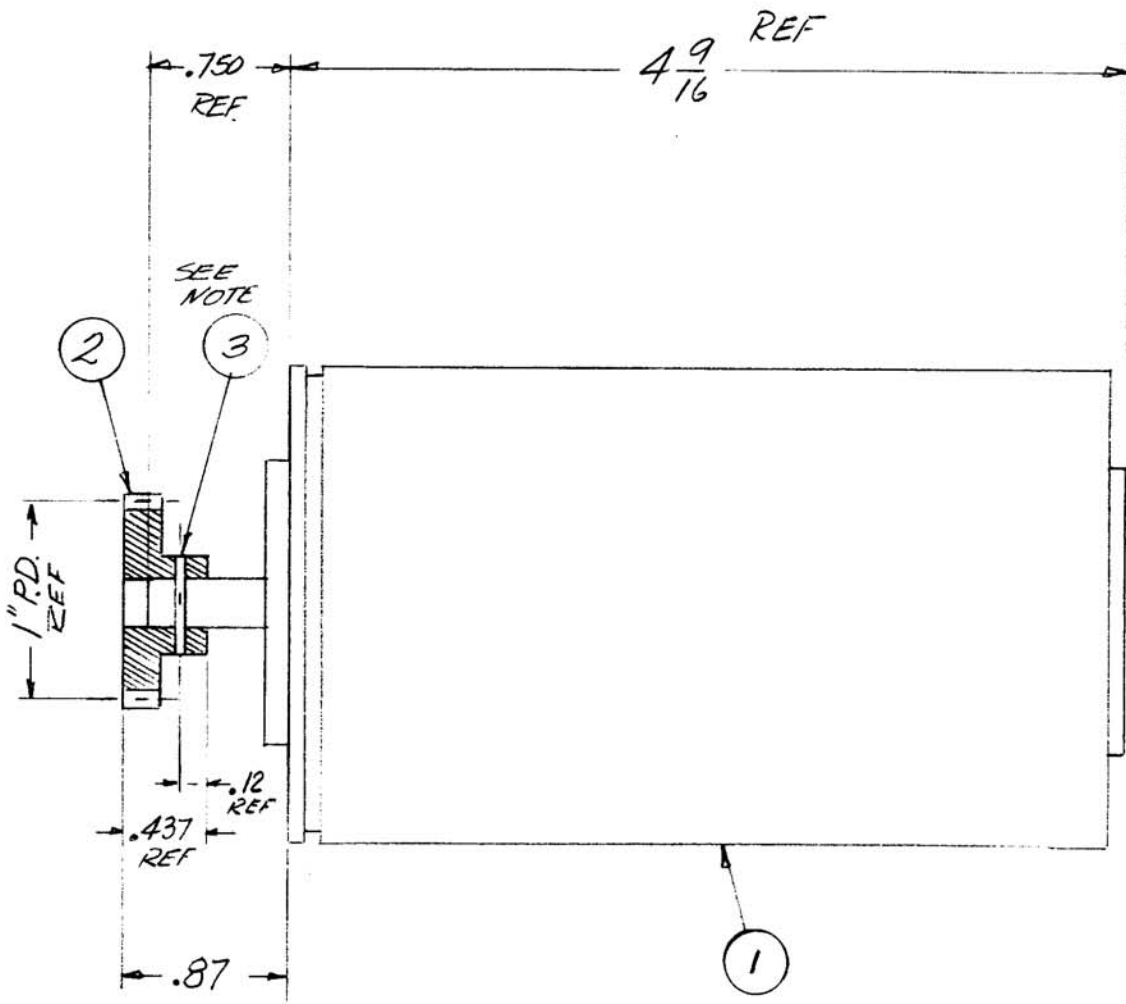

NOTE: #45 (.082) DRILL & TAPER
REAM FOR #5/0 TAPER PIN AT ASSEM.

REQ'D	ITEM	PART NUMBER	DESCRIPTION	SYM.
1	3	PN 121-1	PIN, TAPER	
1	2	GR205-43	GEAR, PIC CAT. No. G4124	
1	1	MO-129	GEAR MOTOR	

UNLESS OTHERWISE SPECIFIED DIMENSIONS ARE IN INCHES AND INCLUDE CHEMICALLY APPLIED OR PLATED FINISHES

DECIMALS	FRACTIONS	TOLS.	ANGLES
.X ± .05	1/64		0° - 30'
.XX ± .01			
.XXX ± .005			

MATERIAL	MECH. DES. J. ANGER	DATE 6/13/69
FINISH	ELECT. DES.	DATE
	CHECKED	DATE
	DRAWN J. ANGER	DATE 6/13/69

LIST OF MATERIAL

THE TECHNICAL MATERIEL CORP.
MAMARONECK, NEW YORK

MOTOR & GEAR ASSEMBLY

NOTICE TO PERSONS RECEIVING THIS DRAWING THE TECHNICAL MATERIEL CORPORATION claims proprietary right in the material disclosed hereon. This drawing is issued in confidence for engineering information only and may not be reproduced or used to manufacture anything shown hereon without permission from THE TECHNICAL MATERIEL CORPORATION to the user. This drawing is loaned for mutual assistance and is subject to recall at any time.	SIZE	CODE IDENT. NO.	DWG NO.	ISSUE
	A	82679	A4811	Ø
SCALE	—		SHEET	1 OF 1