

REQ. PER UNIT	2
MODEL	GPT-10KLF
ASSY. NO.	AX531
DATE	3-22-66

A4093

A

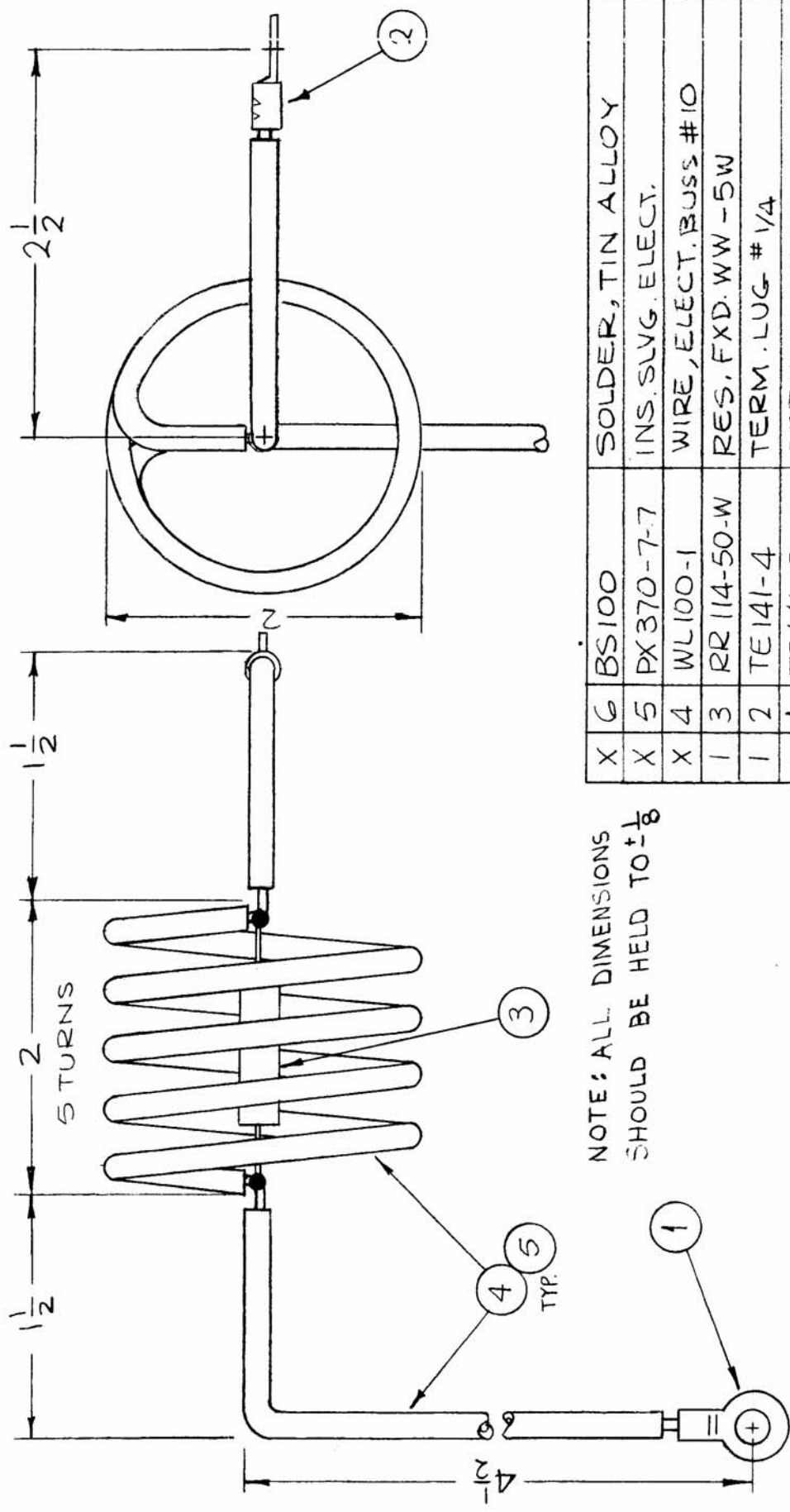

NOTE: ALL DIMENSIONS SHOULD BE HELD TO  $\pm \frac{1}{8}$

X 6	BS100	SOLDER, TIN ALLOY
X 5	PX370-7-7	INS. SLVG. ELECT.
X 4	WL100-1	WIRE, ELECT. BUSS #10
1 3	RR 114-50-W	RES. FXD. WW -5W
1 2	TE141-4	TERM. LUG # 1/4
1 1	TE141-3	TERM. LUG #10

REQ. ITEM	PART NO.	F. BUDETTI DESCRIPTION	SYMBOL
THE TECHNICAL MATERIEL CORP. MAMARONECK, NEW YORK			
PARASITIC SUPPRESSOR ASSY (PLATE)			
STOCK SIZE			
MATERIAL			
TYPE & TEMPER	HEAT TREAT. SPEC.	CHECKED	FINAL APPROVAL
FINISH & SPEC. NO.	A4093		

DATE	CH. NO.	DRAFTS	CHECKER	ENG. APP.
7-26-66	16645	RME	JCP	JCP
3-24-66		H/A		M/D
SCALE	1:1			
DESCRIPTION	UNLESS OTHERWISE SPECIFIED DIMENSIONS ARE IN INCHES AND INCLUDE CHEMICALLY APPLIED OR PLATED FINISHES			
ADDED DIM. NOTE	ORIGINAL RELEASE FOR PRODUCTION			
TOLERANCES	FRACTIONS $\pm 1/64$ ANGLES $\pm 0^\circ 30'$			
DECIMALS	.X $\pm .05$ .XX $\pm .01$ .XXX $\pm .005$			
CODE	A			