

REQ. PER UNIT	USED ON	MODEL	DATE
1	HERR-2	A 3533	2-9-64
		ASSY. NO.	

A-3486 A

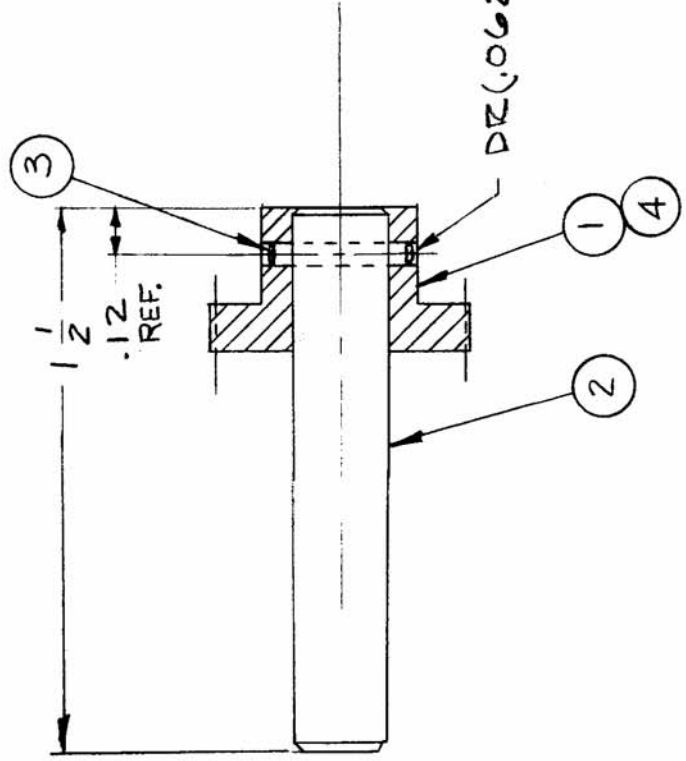

DE(.062-.065) DIA THRU & PIN WITH ITEM #3

REQ. ITEM	PART NO.	DESCRIPTION	SYMBOL
1 4	SLHCO632SS2	SET SCREW	
1 3	PN59-062-6	PIN, SPRING	
1 2	PM1051-RF1500	SHAFT	
1 1	GR 205-3	GEAR	
MATERIAL		THE TECHNICAL MATERIEL CORP.	
STOCK SIZE		MAMARONECK. NEW YORK	
MATERIAL		GEAR ASSY	
MATERIAL		(TURRET)	
TYPE & TEMPER	HEAT TREAT. SPEC.	DRAWN	CHECKED
		Skawie @ 3-3-64	RAT
FINISH & SPEC. NO.		ELEC. DES. APP.	MECH. DES. APP.
		T. Kraw	A 3486
CODE		FINAL APPROVAL	
A			

ADD ITA	DATE	CHECKER	ENG. APP.
ORIGINAL RELEASE FOR PRODUCTION	2-26-66	RME	[Signature]
EXP. RELEASE	3-13-64	[Signature]	[Signature]
DATE	CH. NO.	DRAFTS	CHECKER
3/5/64	4		@
SCALE		2:1	
UNLESS OTHERWISE SPECIFIED DIMENSIONS ARE IN INCHES AND INCLUDE CHEMICALLY APPLIED OR PLATED FINISHES			
TOLERANCES			
FRACTIONS			
DECIMALS			
.X ± .05			
.XX ± .01			
.XXX ± .005			