

THE CONTENTS OF THIS DRAWING ARE THE EXCLUSIVE PROPERTY OF THE TECHNICAL MATERIEL CORP. ITS UNAUTHORIZED USE OR REPRODUCTION IN WHOLE OR IN PART IS STRICTLY FORBIDDEN.

REQ. PER UNIT	1
MODEL	GPT-200K
ASBY. NO.	AP-109
DATE	1-9-63
USED ON	
ASBY. NO.	AP-111
DATE	5-31-63

A-2703 B

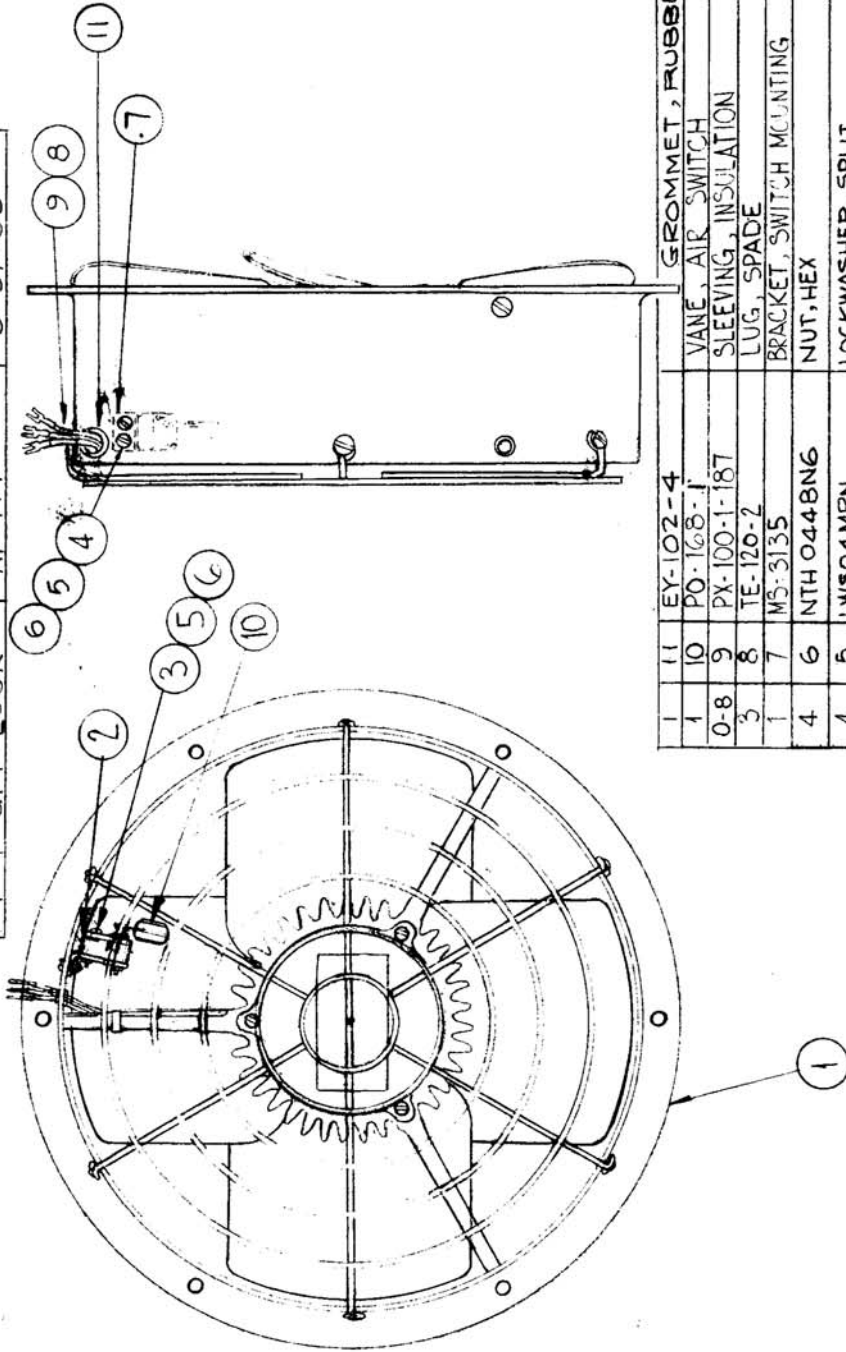

1	11	EY-102-4	GROMMET, RUBBER
1	10	PO-168-1	VANE, AIR SWITCH
0-8	9	PX-100-1-187	SLEEVING, INSULATION
3	8	TE-120-2	LUG, SPADE
1	7	M5-3135	BRACKET, SWITCH MOUNTING
4	6	NTH 0448NG	NUT, HEX
4	5	LWS04MRN	LOCKWASHER, SPLIT
2	4	SCBPO4408NG	SCREW, MACHINE
2	3	SCBPO4408N14	SCREW, MACHINE
1	2	SW-252	SWITCH, AIRFLOW
1	1	BL-114	FAN, TUBEAXIAL

REG. ITEM	PART NO.	DESCRIPTION	SYMBOL
		F. BUDETTI	
STOCK SIZE			
MATERIAL			
THE TECHNICAL MATERIEL CORP. MAMARONECK, NEW YORK			
FAN, SUB-ASS'Y, TUBEAXIAL			
TYPE & TEMPER			
HEAT TREAT. SPEC.			
MATERIAL			
DRAWN			
CHECKED			
FINAL APPROVAL			
FINISH & SPEC. NO.			
ELEC. DES. APP. MECH. DES. APP.			

DATE	CH. NO.	DRAFTS	CHECKER	ENG. APP.
6-22-65	14272	DVK	JL	
5-14-65	14081	WJL	JL	
5-16-64		MSB		
SCALE:				
UNLESS OTHERWISE SPECIFIED:				
DIMENSIONS ARE IN INCHES				
TOLERANCES ON				
FRAC. ± 1/64 DEC. ± .005 ANGLES ± 1/2°				
MAXIMUM ALLOWABLE TOLERANCES HAVE BEEN DETERMINED AND ANY DEVIATIONS WILL BE CAUSE FOR REJECTION. REMOVE ALL BURRS AND SHARP EDGES				