

A-2519 A

REVISIONS

SYM	DESCRIPTION	DATE	E.M.N. NO.	DRAFT	CHKD	APPD
A	IT 5 WAS BX199-2 IT 7 WAS BS106-4 IT 8 WAS BS106-2	4-19-66	16102	WHD	<i>[Signature]</i>	<i>[Signature]</i>

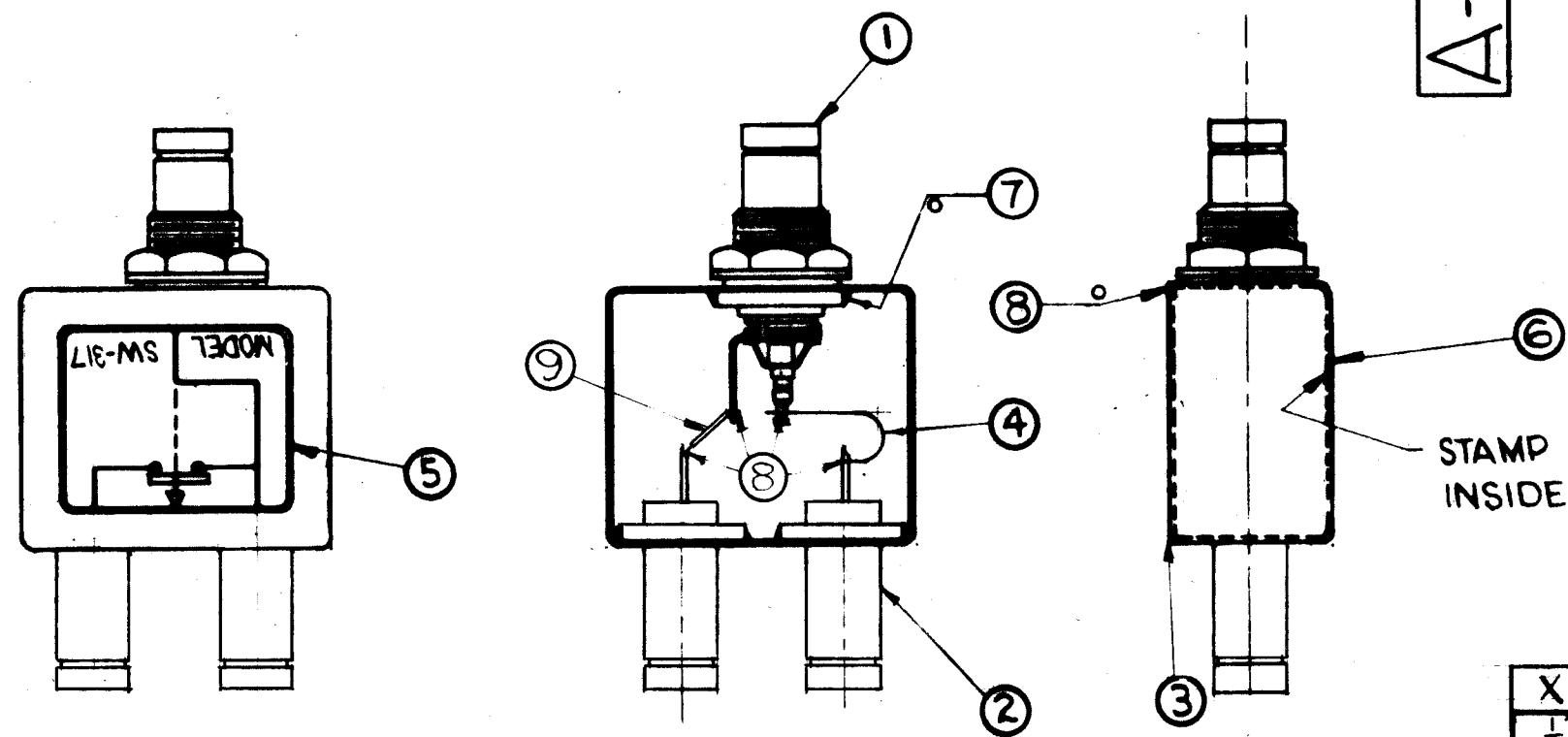

STAMP DATE ON INSIDE SURFACE

- INDUCTION HEATING EQUIPMENT SET AT:
AMPERES -
SECONDS -
- USE ITEM SEVEN(7) FOR MOUNTING ITEMS ONE(1) AND TWO(2).
- USE ITEM EIGHT(8) FOR SEALING COVER ITEM THREE(3).
- STRAP (ITEM 4) MUST BE KEPT AS FLEXIBLE AS POSSIBLE. DO NOT ALLOW SOLDER TO RUN OVER STRAP. LAY STRAP IN SO THAT IT CANNOT TOUCH CAN OR CONNECTOR BODIES.
- FINISH AS FOLLOWS:
S-114 - ZINC CHROMATE PRIMER
S-115 - TMC SMOOTH GREY ENAMEL
(DO NOT PAINT CONNECTOR BODIES.)
- AFFIX ITEM FIVE(5) TO FRONT AS SHOWN.
- AFFIX ITEM SIX(6) TO REAR AS SHOWN.

○ DENOTES SOLDER ALL AROUND
NOTES

REQ'D.	ITEM	PART NUMBER	DESCRIPTION	SYMBOL
X	10	S-692	TEST PROCEDURE	
1/2	9	WL-100-5	WIRE, BUSS-BAR #18	
X	8	BS-100	SOLDER, TIN ALLOY	
X	7	BS-100-2	SOLDER, TIN ALLOY	
1	6	NP-488	NAMEPLATE IDENTIFICATION (FOIL CAL.)	
1	5	NP-489-G	SCHEMATIC, DIAGRAM (FOIL CAL.)	
1	4	MS-2983-3	STRAP, FLEXIBLE CONNECTOR	
1	3	BX-199-1	CASE, COVER	
2	2	JJ-253	ADAPTOR, CONNECTOR	
1	1	JJ-239	ADAPTOR, CONNECTOR	

LIST OF MATERIAL

MATERIAL SEE LIST	THE TECHNICAL MATERIEL CORP. MAMARONECK, NEW YORK		
FINISH SEE NOTE NO.5	TITLE SW-317 ASSEMBLY		
UNLESS OTHERWISE SPECIFIED DIMENSIONS ARE IN INCHES AND INCLUDE CHEMICALLY APPLIED OR PLATED FINISHES	DRAWN <i>R. Furchin</i>	DATE 6-13-62	FINAL APPROVE <i>[Signature]</i>
	CHECKED <i>[Signature]</i>	DATE 6-26-62	DATE
DECIMALS .X ± .05 .XX ± .01 .XXX ± .005	TOLERANCES	FRAGMENTS ± 1/64 ANGLES ± 30'	DATE 6/27/62
ELECT. DES. <i>[Signature]</i>		DATE	A-2519
MECH. DES. <i>[Signature]</i>		DATE	A
SHEET			REV. LTR.

1	SW-317	A-2519
QTY./UNIT	MODEL USED ON	ASSY. NO.
SCALE DO NOT SCALE	CODE	
THE CONTENTS OF THIS DRAWING ARE THE EXCLUSIVE PROPERTY OF THE TECHNICAL MATERIEL CORP. ITS UNAUTHORIZED USE OR REPRODUCTION IN WHOLE OR IN PART IS STRICTLY FORBIDDEN.		