

A-1767 B

THE CONTENTS OF THIS DRAWING ARE THE EXCLUSIVE PROPERTY OF THE TECHNICAL MATERIEL CORP. ITS UNAUTHORIZED USE OR REPRODUCTION IN WHOLE OR IN PART IS STRICTLY FORBIDDEN.

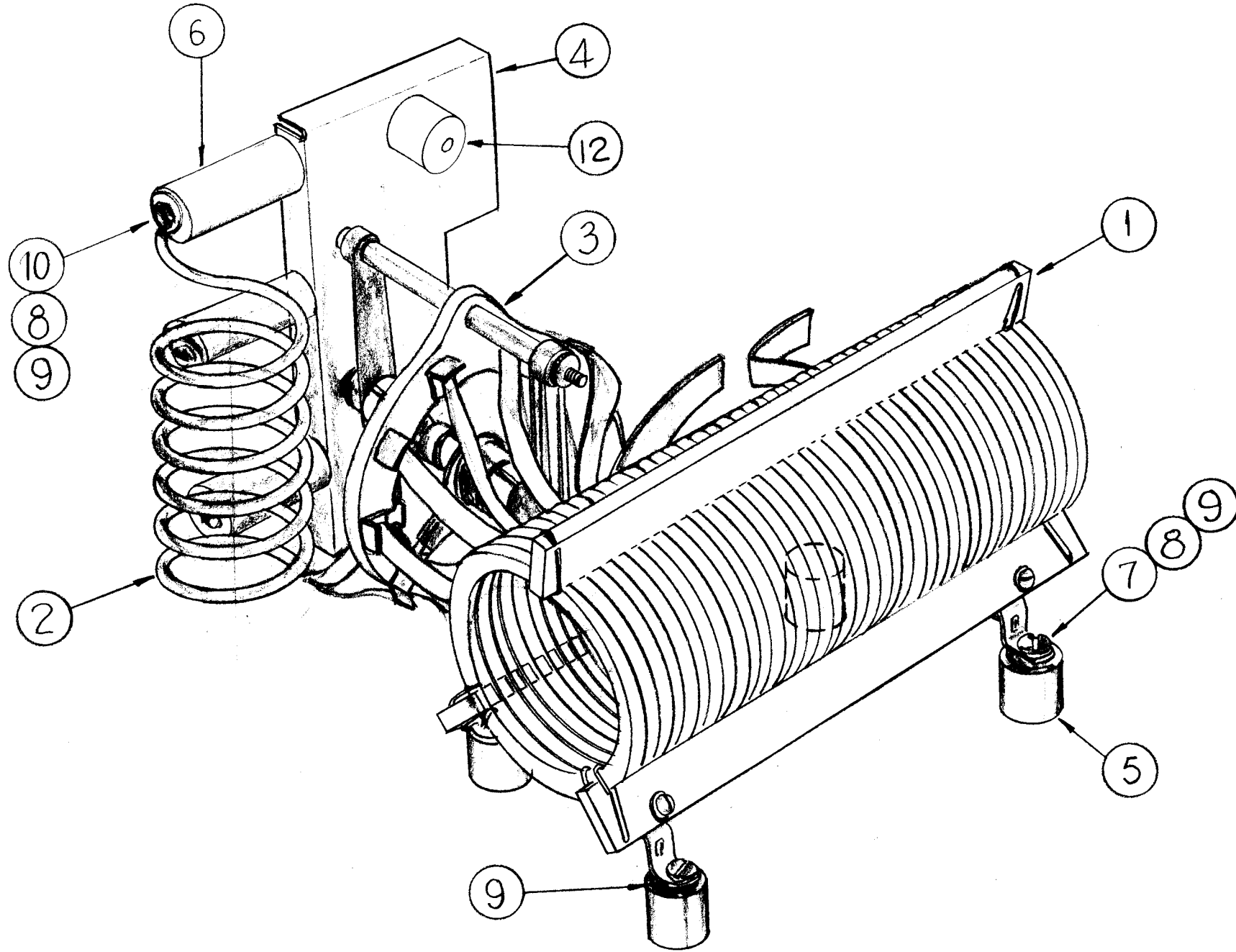

1	12	NS3W0206	INSULATOR, PILLAR, RD	E108
X	11	BS-104	Eutetic Tin Weld #1	
6	10	SCBPI032BN8	Screw, Machine	
11	9	WA-109-54	Washer, Fiber	
11	8	LWE10MRN	Lockwasher, Ext.	
5	7	SCBPI032BN6	Screw, Machine	
3	6	NS3W0314	Insulator, Pillar, Rd	E117,18,19
4	5	NS3W0306	Insulator, Pillar, Rd	E112,13,14,15
1	4	LD282/MS1394	Bracket, Rear Switch	
1	3	SW-166	Switch, Antenna Load	S102
1	2	A-1208	Coil, Tank H.F.	L112
1	1	A1209	Coil, PA Tank ASSEMBLY	L113

REQ.	ITEM	PART NO.	DESCRIPTION	SYMBOL
		++	THE TECHNICAL MATERIEL CORP. MAMARONECK, NEW YORK	
		#	AX-141 ASSEMBLY BANDSWITCH ASS'Y, TANK COIL	
		++	DRAWN: [Signature] CHECKED: [Signature] FINAL APPROVAL: [Signature]	
		++	TYPE & TEMPER HEAT TREAT. SPEC. FINISH & SPEC. NO. ELEC. DES. APP. MECH. DES. APP.	

B	B/M UPDATED	11.18.66	17269	WHD	[Signature]	[Signature]
A	CALLOUT 12 WAS 5 IT. 5 WAS 5 REQ, IT. 12 ADDED	11.9.64	12874	KB	@	[Signature]
SYM	DESCRIPTION	DATE	CH. NO.	DRAFTS	CHECKER	ENG. APP.
UNLESS OTHERWISE SPECIFIED: DIMENSIONS ARE IN INCHES TOLERANCES ON FRACTIONS ± 1/64 DECIMALS ± .005 ANGLES ± 1/2°		SCALE: $\frac{1}{2}$ " = 1"		MAXIMUM ALLOWABLE TOLERANCES HAVE BEEN DETERMINED AND ANY DEVIATIONS WILL BE CAUSE FOR REJECTION. REMOVE ALL BURRS AND SHARP EDGES		
1	AX-141	RTF-2	GPT-750(N)	3-13-62	USED ON	
REQ. PER UNIT	MODEL	SECTION	ASS'Y. NO.	DATE		