

A-1640 E

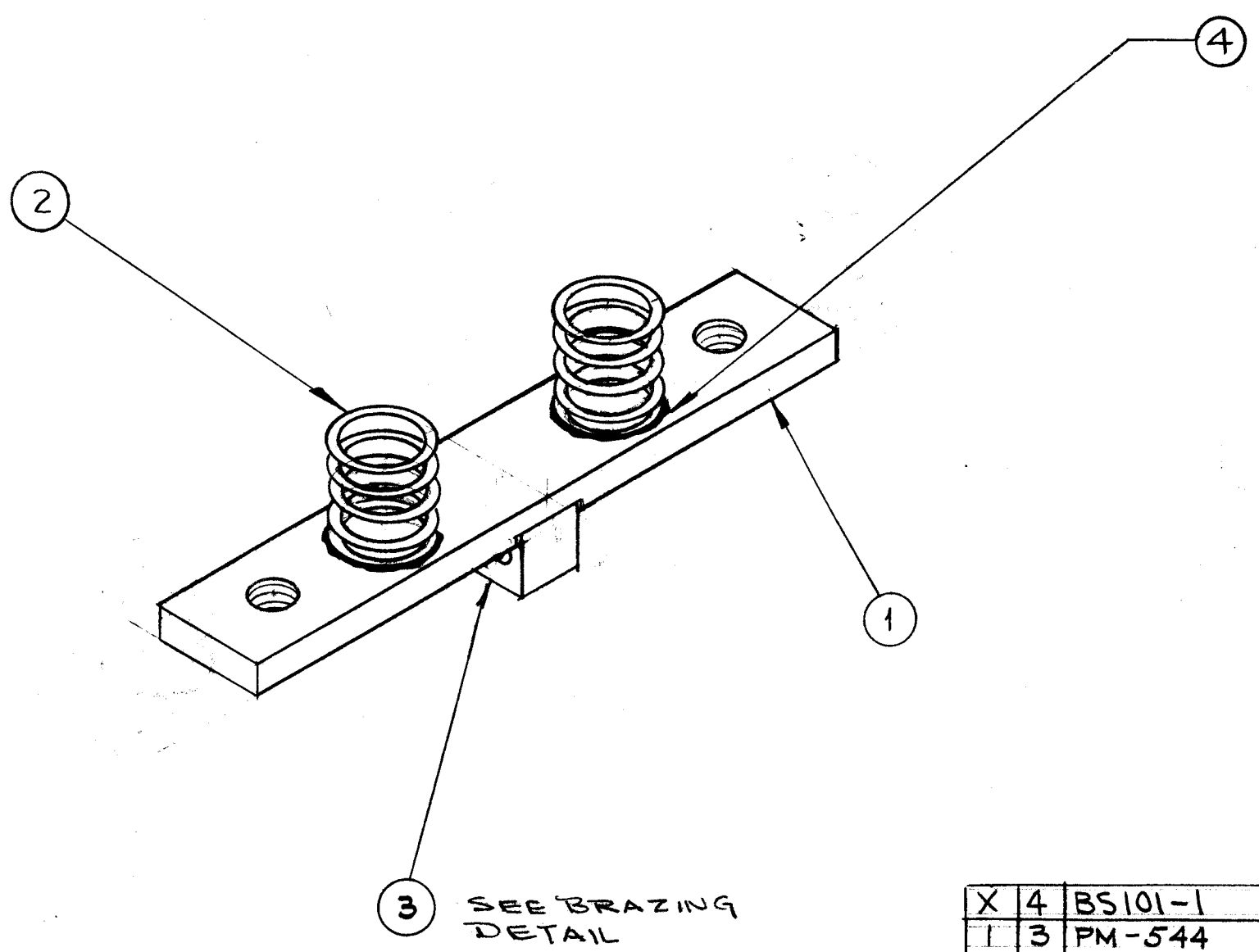
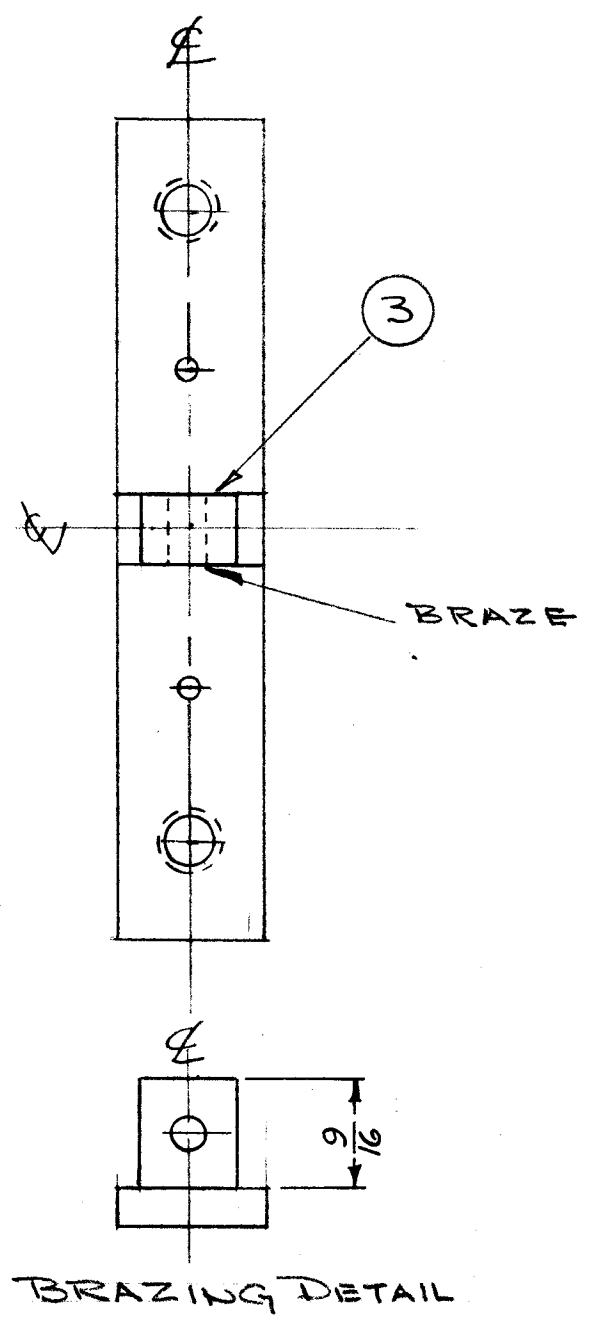

NOTICE TO PERSONS RECEIVING THIS DRAWING

THE TECHNICAL MATERIEL CORPORATION claim proprietary right in the material disclosed hereon. This drawing is issued in confidence for engineering information only and may not be reproduced or used to manufacture anything shown hereon without permission from THE TECHNICAL MATERIEL CORPORATION to the user. This drawing is loaned for mutual assistance and is subject to recall at any time.

Property of:
THE TECHNICAL MATERIEL CORPORATION
MAMARONECK, NEW YORK

REQ. ITEM	PART NO.	DESCRIPTION	SYMBOL
X 4	BS101-1	SOLDER, SILVER	
1 3	PM-544	PLUNGER SUP. HV. SHORTING RELAY	
2 2	SP-128	SPRING, FRICTION DRIVE	
1 1	PM-534	BAR, CONTACT	
THE TECHNICAL MATERIEL CORP. MAMARONECK, NEW YORK			
BAR CONTACT ASSEMBLY GPT-10K			
MATERIAL		J.C. BIELE	
TYPE & TEMPER		DRAWN	CHECKED
HEAT TREAT. SPEC.		FINAL APPROVAL	
FINISH & SPEC. NO.		A-164	

ISSUE	ITEM	CHANGED FROM	DATE	CH. NO.	DRAFTS	CHECKER	ENG. APP.
E		ADDED IT. 4	11/3/66	17092	RME		
D	1	UPDATED & CLARIFIED	11/16/63	10523			
C	1	9/16 DIM. ADDED	10-13-60	3187			
B	2	ITEM 2 ADDED	11/18/59	1505	PI		
A	1	ITEM 2 WAS 3 REQ	8/26/59	1230			

REQ. PER UNIT	MODEL	PROJECT NO.	ASS'Y. NO.	DATE
2	GPT10K()5	AX-138	A-1690	12-10-63
1	GPT10K	AR-109		2-14-59

USED ON