

REQ. PER UNIT	1	USED ON	A-1568
MODEL	SBE-2	ASSY. NO.	
		DATE	8-19-58

# STANDARD DRAWING

SPRING (SUPPLIED BY MFG.)  
HOLDS ITEMS 2 & 3 IN PLACE.

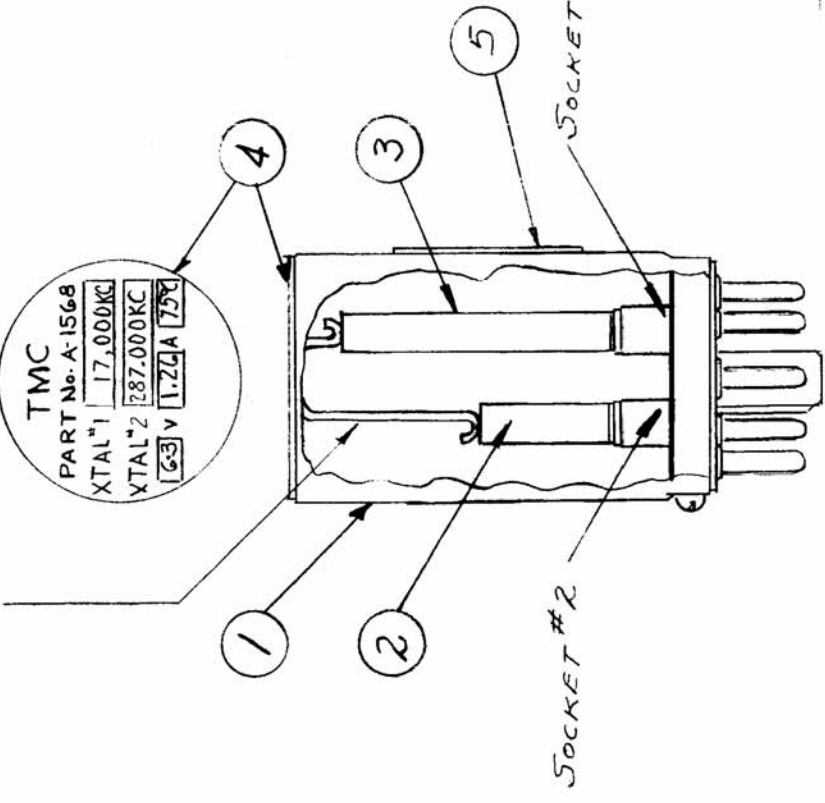

ATTACH TO SIDE (1X1 ALUM. BRK.)

1	5	NP-237	SCHEMATIC DIAGRAM	SYMBOL
1	4	NP-236	NAME PLATE IDENTIFICATION	
1	3	CR-112	CRYSTAL 17KC	Y109
1	2	CR47/287,000KC	CRYSTAL 287KC	Y110
1	1	PO-147	OVEN, CRYSTAL	
REQ. ITEM	PART NO.	DESCRIPTION		
		THE TECHNICAL MATERIEL CORP. MAMARONECK. NEW YORK		
		CRYSTAL ASSY		
		SBE-2		
		8-19-58		
		DRAWN: RWB		
		CHECKED: JLD		
		FINAL APPROVAL: DRB		
TYPE & TEMPER		HEAT TREAT. SPEC		
FINISH & SPEC. NO.		ELEC. DES. APP. MECH. DES. APP.		

KEY RELOCATED	10.21.64	12723	AM	AM	AM	AM	AM	AM	AM
IT-2 WAS CR47/U.287P									
ITEM 3 WAS CR50/U	4-8-64	11191	AM	AM	AM	AM	AM	AM	AM
Pictorial Clarified	12-28-60	3825	RU	RU	RU	RU	RU	RU	RU
ISSUE ITEM	CHANGED FROM	DATE	CH. NO.	DRAFTS	CHECKER	ENG. APP.	SCALE:		
TOLERANCES							MAXIMUM ALLOWABLE TOLERANCES HAVE BEEN DETERMINED AND ANY DEVIATIONS WILL BE CAUSE FOR REJECTION. REMOVE ALL BURRS AND SHARP EDGES		
DEC. DIM. ±									
FRAC. DIM. ±									
ANGULAR DIM. ±									