

INSTRUCTIONS FOR INSTALLING THE 178316, 178343, 178345,  
AND 178346 MODIFICATION KITS ON MODEL 28 AUTOMATIC  
SEND-RECEIVE SETS (ASR) TO PROVIDE AN ANSWER-BACK  
MECHANISM

The chart below pertains to Bell System only

Teletype Unit	Teletype Code	Bell System Reference	Bell Code
Perforator Transmitter	LAK	Perforator Transmitter Base	28A & up
Transmitter Distributor Base	LCXB	Transmitter Distributor Base	28E1, 28E2, & 28H1
Typing Unit	LP10 & up	Typing Unit	28B & up

1. GENERAL

a. The 178316, 178343, 178345, and 178346 modification kits provide an answer-back mechanism for use in dial TWX on the Model 28 Automatic Send-Receive Page Printer Sets (ASR) wired for either half-duplex or full-duplex and containing an electrical service unit (LESU). The answer-back mechanism is an electromechanical device which allows the identity of the called station to be transmitted automatically to the originating station on receipt of the sequential selection "FIGS" - "C" from the signal line.

b. For receiving tape transmission, a delay circuit is incorporated in the answer-back mechanism which permits the receipt of a third character following the sequential "FIGS" - "C" (i.e. "LTRS" in "FIGS" - "C" - "LTRS") before transmission of the answer-back message begins.

c. A control relay actuated by the local station signal generator prevents the local station answer-back mechanism from operating when a distant station has been called. Local answer-back may be operated from the local red "HERE IS" keylever.

d. A subset actuated relay initiates answer-back operation from a Bell System Data-Phone Subset.

e. All four kits are necessary to provide answer-back operation with Model 28 Automatic Send-Receive Sets and must be ordered separately.

f. The basic function of the 178316 modification kit is to provide an answer-back feature on Automatic Send-Receive Sets (ASR) having a LCXB transmitter distributor base.

g. Due to the overall height of the 178317 distributor assembly which is the motive portion of the 178316 modification kit, this modification kit is not compatible with ASR Sets containing an auxiliary reperforator and base.

h. The 178316 modification kits is similar to the 176715 modification kit and although basic parts are interchangeable, the complete kit is not interchangeable due to the special gear drive and base casting required for the 176715 modification kit.

i. The 178343 modification kit provides only those parts of the answer-back mechanism common to the Model 28 Typing Unit (LP10 and up) and supplies the control from "FIGS" "C" keylever. The typing unit must have stunt box slots 29, 30, 31, 32, 33, 34, 35 and 36 available to utilize the 178343 modification kit. Later versions of the 178343 modification kit require only slots 31, 32, 33 and 34.

j. The 178345 modification kit is a dual purpose modification kit. This kit provides all parts of the answer-back mechanism common to the electrical service assembly (LESU); the kit also contains a motor control feature.

(1) The motor control feature is electrically independent of the answer-back mechanism and is incorporated into the 178345 modification kit only to conserve mounting facilities. For this reason the motor control feature comes with the 178345 modification kit.

(2) The basic components of the 178345 modification kit are:

Motor control relay (independent of answer-back feature).  
Subset actuated relay for answer-back operation from Bell System  
Data-Phone Subset  
Resistor-diode-capacitor-network to provide delay feature.

k. The 178346 modification kit provides only those parts of the answer-back mechanism common to the Model 28 Keyboard (LAK). The basic parts are a signal generator "pulsing" or "blinding" contact, "Here Is" keylever and associated contact, and "non-contention" or answer-back control relay.

l. The answer-back control relay (or non-contention relay) is connected to the 115 v ac 60 cycle supply circuit of the keyboard and operating current is approximately .035 amperes.

## 2. THEORY OF OPERATION

a. CLUTCH ASSEMBLY - Clutch assembly operation is similar to the clutch operation of the LXD. See Teletype Model 28 Bulletin 258B.

b. CAM SLEEVE ASSEMBLY AND CONTACT ARRANGEMENT - As the cam sleeve rotates a drive lever assembly is actuated by the associated cam surface to index the code message drum for the first character of transmission. As the cam sleeve assembly continues to rotate its individual cams and cam followers actuate their respective contact levers which control the opening and closing of the distributor contacts. (The contacts are only permitted to close if a tine is removed from its respective code blade on the code message drum - See Figure 14 of this specification.

c. CLUTCH TRIP MAGNET ASSEMBLY - For general theory of operation see Teletype Model 28 Bulletin 234B.

d. CLUTCH TRIP MAGNET ASSEMBLY (Special) - The clutch trip magnet assembly is wired in series with a pair of contacts so that upon the initiation of a message the contacts are closed and remain closed until the stop blade engages its associated cam follower actuator and causes the circuit to open up and latch the clutch mechanism. (Before latching up the distributor portion is allowed to sense and transmit this last character.)

e. The theory of operation for sequential "FIG - C" control feature, non-contention control feature, "HERE IS" keylever control and Data-Phone Subset control is the same as that described in Teletype Specification 50060S.

f. The 178316 modification kit consists of:

3	2191	Lockwasher	1	153442	Screw
1	2669	Lockwasher	1	176163	Wire Assembly, Elect.
1	3438	Washer, Flat	1	172985	Shaft W/Bearings & Gear
1	80706	Screw	1	178317	Distributor Assembly
3	125015	Washer, Flat	1	178323	Cable Assembly
3	151631	Screw	1	195176	Guard, Contact

g. The 178343 modification kit consists of:

3	4703	Spring	2	152666	Bar, Function
3	72522	Wick	1	153520	Bar, Function
3	90517	Spring	1	154613	Latch
3	94693	Wick	3	157200	Spring
1	152121	Lever, Function	3	157240	Spring
2	152642	Lever, Function	1	178347	Cable Assembly, Function Box
2	152653	Pawl, Function			
2	152660	Plate, Spring	1	195016	Pawl Function Assembly

h. The 178345 modification kit consists of:

12	2191	Lockwasher	3	151722	Screw
4	3598	Nut	8	153484	Screw
3	7002	Washer, Flat	3	155753	Tubing, Insulating
41 ft.	60339RM	Tubing, Insulating	1	162864	Clamp, Cable
1	74821	Resistor	1	165522	Diode (420B)
1	76461	Washer, Flat	2	178306	Relay
2	75750	Washer, Insulating	1	178308	Cable Assembly
1	77902	Screw	1	178326	Capacitor
2	90789	Washer, Flat	1	178327	Cable W/Connector
2	150040	Screw	1	178328	Bracket, Mounting
4	150995	Spacer	1	178330	Plate
2	151427	Plate, Clamp	2	178535	Spark Suppressor
1	151630	Screw	4	179782	Screw
2	151692	Screw			

i. The 178346 modification kit consists of:

1	1178	Screw	1	162885	Cam, Segment
8	2191	Washer	2	162886	Screw
2	3599	Nut	1	163852	Keylever Assembly, "Here Is"
5	7002	Washer	1	163979	Lever, Function
1	71013	Washer	1	164457	Keylever, Assembly, W-R-U Upp. Case C
1	93117	Washer			
2	110743	Washer	1	174184	Plate, Cover
1	112627	Nut	1	178329	Cable Assembly
1	121246	Clamp, Cable	1	178331	Cable Assembly, Keylever Contact
2	121473	Stud			
3	151630	Screw	1	178349	Cable Assembly, Control Relay
1	153538	Screw			
2	153817	Screw	1	309508	Bracket
1	154125	Spring	1	309509	Bracket
2	155753	Tubing, Insulating	2	309510	Bar, Retainer
4	156740	Screw	1	321727	Guide
1	162878	Contact Assembly, Universal Kybd.			

j. For part numbers referred to, other than those in the modification kits, and for parts ordering information see Teletype Model 28 Page Printer Parts Bulletin 1149B.

### 3. INSTALLATION

#### NOTE

References in the text to left or right, front or rear, up or down, apply to the unit in its normal operating position as viewed from the front, unless specifically stated otherwise.

a. The 178316 modification kit

- (1) Remove the existing main shaft on the LCXB transmitter distributor base and replace it with the new 172985 shaft assembly.
- (2) Mount the 178316 modification kit on the LCXB base referring to Figure 1.
- (3) Mount the 195176 contact guard on the cabinet wall such that the guard covers the contact assembly. Secure with the 80706 screw.
- (4) Mesh, align and adjust the 157165 fiber idler gear, on the 178317 distributor assembly, with the 164967 gear, part of the 172985 shaft assembly, before securing the four mounting screws. Use the slotted holes for this purpose.

NOTE

The 178323 cable assembly is provided with this kit for electrical interconnection between the associated keyboard (LAK) and the cabinet (LAAC) terminal strip. Refer to wiring diagram 4494WD for information regarding the wire terminations on the "C" cabinet terminal strip.

b. The 178343 modification kit

- (1) Remove the typing unit from the cabinet in accordance with standard practice. Do not replace until so instructed.
- (2) Remove the stunt box from the typing unit in accordance with standard practice.
- (3) Install the following parts in slot No. 32. When slot 32 is not available install these parts in slot 26.

<u>Part No.</u>	<u>Description</u>
195016	Pawl, Function Assembly
157240	Spring
72522	Wick
157200	Spring
94693	Wick
152666	Bar, Function "Figs"
4703	Spring

- (4) Install the following parts in slot No. 33:

<u>Part No.</u>	<u>Description</u>
152653	Pawl, Function
157240	Spring
72522	Wick
157200	Spring
94693	Wick

<u>Part No.</u>	<u>Description</u>
152666	Bar, Function "Figs"
4703	Spring
152121	Lever, Function
90517	Spring
154613	Latch

(5) Install the following parts in slot No. 34:

<u>Part No.</u>	<u>Description</u>
152653	Pawl, Function
157240	Spring
72522	Wick
157200	Spring
94693	Wick
153520	Bar, Function "C"
4703	Spring
152642	Lever, Function
90517	Spring
152660	Plate, Spring

(6) Use the 157240 spring and 72522 wick on units having a one stop function clutch; use the 157200 spring and 94693 wick on units having a two stop function clutch.

(7) If the printer stunt box is equipped with the blank-blank keyboard lock sequence parts, and if it is desired to disable this feature, install the 152127 clip. Position the clip with its closed end under the function pawl in slot No. 35 so that it lifts the pawl out of engagement with the function bar when the hooks at the open end of the clip are placed over the 150544 handle.

(8) Install the 172539 switch assembly (part of 178347 cable assembly) across stunt box slots number 31, 32, 33 and 34. Earlier versions used slots 29, 30, 31, 32, 33 and 34.

(9) Replace the stunt box in the printer. Adjust the 195016 function pawl as shown in Figure 8. Route the switch cable along the 150544 handle to the connector side of the printer.

(10) When the "Figs" contact adjustment has been made route the switch cable along the 150544 handle.

(11) Tie the cable to the handle at the appropriate positions to the connector side of the printer.

c. The 178345 modification kit (shipped assembled)

(1) Remove the two electrical service assembly mounting studs for access to the service assembly. Remove and discard the 151441 blank plate that is mounted on the electrical service unit next to the cover plate that contains the fuse socket and convenience receptacle. Install the 178345 modification kit in place of the 151441 blank plate. (See 4481WD). Route and connect the 178308 cable assembly and 178327 cable assembly to the appropriate service assembly terminal blocks as shown in 4481WD.

(2) Replace the electrical service assembly, keyboard hood, keyboard and typing unit in accordance with standard practice.

(3) Connect the two keyboard connectors to the associated typing unit connector and the electrical service unit connector. Check cables for possible interference. Tie the cables to the electrical service unit end posts to insure that the cables are held away from the motor.

d. The 178346 modification kit:

(1) Remove the keyboard from the cabinet in accordance with standard practice.

(2) Remove the keyboard hood in accordance with standard practice.

(3) Remove the keylever guide plate in accordance with standard practice.

(4) Remove and discard the plastic plug and speed nut from the keytop hole, sixth from the left in the top row.

(5) Maneuver the 163979 function lever into the 21st slot of the 154070 code lever guide until it is fully seated on the 154016 code bar lever shaft.

(6) Install a 154125 spring on the 163979 function lever and 154070 code lever guide.

(7) Replace the keylever guide plate on the keyboard in accordance with standard practice. Re-adjust the space bar bail pivot. (Refer to Bulletin 250B.) Do not replace the keyboard hood until so instructed.

(8) Remove the lock ball retainer clamp from its present position in the center of the lock ball channel and install it in the position immediately to the right of center. Some keyboards may not have a lock ball retainer clamp in the center of the lock ball channel. If so, disregard this paragraph.

(9) Install the 163852 keylever assembly (Here Is) in the keytop guide hole previously unplugged, snapping onto the 163979 function lever previously installed in this position. See Figure 2.

(10) Remove the existing "C" keylever assembly and replace with the 164457 W-R-U upper case "C" keylever assembly.

(11) Remove the two screws, lockwashers and flat washers (one at a time on each side), holding the lockball channel. Install two 121473 studs with the lockwashers and flat washers just removed. (See Figure 2.)

(12) Check and if necessary, make the lock ball channel adjustment.

(13) Place the 309508 and 309509 brackets on top of each 121473 stud and assemble them only friction tight with two 156740 screws, 2191 lockwashers and 7002 flat washers. (See Figure 2.)

(14) Install the 309510 retainer bars to the 309508 and 309509 brackets friction tight with two 156740 screws, 2191 lockwashers, and 7002 flat washers. (See Figure 2.)

#### NOTE

Use caution when handling the 309507 contact to be installed according to the next paragraph.

(15) Install the 309507 contact assembly (part of 178331 cable assembly) on the retainer bars and assemble it only friction tight with the 1178 screw, 71073 flat washer, 93117 lockwasher, and 112627 nut. Move the contact assembly along the retainer bar until it is beneath the 153979 function lever previously installed. Tighten the assembly. Route the white-brown (W-BR) and slate (S) wires through the keyboard base to the signal generator. Tie the cable assembly near the end of the retainer bar on both sides of the contact assembly. (See Figure 2.)

(16) Route the slate (S) wire through the keyboard to the motor terminal block. Route the white-slate (W-S), and white-brown (W-BR) wires with terminals as far as possible toward the rear of the keyboard for later connection to the 178349 or 178340 control relay assembly. (See wiring diagram 4495WD or 4915WD.)

(17) Insert the terminal end of the 178329 cable assembly through one of the slots in the left rear of the keyboard. Route the cable through the rear of the keyboard and around the right corner for later connection to the 178349 control relay assembly.

(18) To facilitate installation of the 178349 control relay assembly in the right rear corner of the keyboard base, connect the white-slate (W-S) and white-brown (W-BR) wires from the 178331 keylever contact cable assembly to the control relay terminal block. Also connect the green (G) and white-slate (W-S) wires from the 178329 cable assembly. (Refer to wiring diagram 4495WD or 4915WD.)



(19) Route the purple (P) and (S) wires from the control relay assembly to the motor terminal block. Route the two six point connectors through the top of the keyboard. (Figure 3).

(20) Secure the 178349 control relay assembly using two 151630 screws and two 2191 lockwashers. (Figure 3).

(21) Install the 174184 control relay cover plate in the following manner: place the 121246 cable clamp over the two cables and insert the 153538 screw, 2191 lockwasher and 7002 flat washer through the cable clamp. Then place the 70314 flat washer beneath the cable clamp and secure the clamp and cover plate to the relay mounting bracket. (The entire control relay assembly is secured at the rear of the keyboard by the 70314 flat washer which overlaps onto the keyboard base.) Secure the other end of the cover plate with a 151630 screw, 2191 lockwasher and 70314 flat washer. (Figure 3).

(22) Connect the purple (P) wire, previously routed, to terminal one of the motor terminal block (see 4495WD).

(23) Connect the two slate (S) wires, previously routed, to terminal two of the motor terminal block (see 4495WD or 4915WD).

(24) Remove the signal generator from the keyboard in accordance with standard practice.

(25) Remove and discard the two 151737 screws which secure the cam sleeve assembly to the clutch cam disk. Retain the lockwashers.

(26) Install the 162885 cam segment with the two 162886 screws and the two lockwashers previously removed. Refer to Figure 4. The 162885 cam segment and 162886 mounting screws can be maneuvered into place without removing any parts from the signal generator assembly.

(27) Install the 162878 universal pulsing or blinding contact assembly on the 154009 signal generator front plate as shown in Figure 4 using two 151631 screws, two 2191 lockwashers and two 7002 flat washers.

(28) Place two 155753 plastic tubing insulators over the bare wires of the 178331 keylever cable assembly previously routed to the signal generator. Solder the slate (S) wire to the contact spring and solder the white-brown (W-BR) wire to the contact stiffener of the 162878 pulsing contact. (Figure 6).

(29) Replace the signal generator on the keyboard in accordance with standard practice. Check, and if necessary, make the code bar and code lever clearance, the code bar bail, the code bar bail and non-repeat lever clearance, the universal bail latch lever, the universal bail extension, the ball wedgelock and ball track clearance and the lock ball and play adjustment. (Refer to Teletype Adjustment Bulletin 250B).

NOTE

Make the 162878 pulsing contact adjustment at this time. (Figures 5, 6, and 7 and Paragraph 4.d.).

(30) Lubricate the answer-back mechanism in accordance with Section 4.

(31) Make the "HERE IS" keylever switch adjustment in accordance with Section 4.

(32) Replace the keyboard hood, keyboard and typing unit in accordance with standard practice.

d. The Answer-Back Message Drum may be changed by replacing the entire code drum mechanism as outlined in Paragraphs (1) thru (6). (Figure 14).

(1) The answer-back message drum has a total capacity of 21 characters. The first character transmitted must always be a "LETTERS" combination; the remaining 20 may be any characters desired. The arbitrary characters are determined by detachable code blades set in a code message drum. Since projections on the code blades are used to rotate the drum, all of its 21 slots must be occupied by a blade.

(2) The last character transmitted is determined by a special stop code blade. Three such blades are included so that the code drum can be equipped with more than one stop code blade to reduce the number of characters in the answer-back message sequence, if desired. Three stop code blades equally spaced about the code drum would result in a message of six arbitrary characters preceded by a "LETTERS" combination. There are twenty-five code blades furnished with this modification kit; this is more than required. The extra blades are furnished for future code arrangements or as a replacement should an error in the original coding be made.

(3) A code blade is coded by breaking off the unwanted tines at the scored line at the base of the tine. The accompanying figure indicates which tines are to be removed for a particular character. To prevent distortion of a code blade, each blade should be held securely near the score mark of the tine to be removed.

(4) Place an "O" ring in the groove on the rim of the message drum which is furthest from the slot in the center portion of the drum. Install a stop blade in any slot position in the drum by first inserting the blade under the "O" ring and then rotating the blade toward the center of the drum until it is fully seated.

(5) Code the drum in a counterclockwise direction beginning with the No. 2 blade adjacent to the stop blade. Install each coded blade in the proper slot position inserting the blade under the "O" ring.

(6) After filling the drum, encircle the blades by placing another "O" ring in the groove on the opposite rim of the drum.

e. Installation of the coded message drum:

(1) Place a thin coat of grease on the shaft and stud of the drive plate. Insert the shaft portion of the drive plate into the message drum (note that due to a difference in hole diameters the message drum can be inserted only one way). Hook the spring between the drive plate and the feed pawl. Oil both ends of the spring.

(2) To insert the message drum assembly into the distributor assembly, trip the clutch and rotate the distributor main shaft until the drive lever assembly is on the high part of the cam, then insert the message drum assembly between the mounting brackets. Note that the drive plate has a stud welded on to it; this stud must go under the drive lever assembly. Then rotate the main shaft to latch the clutch. Next hook the drive plate spring between the drive plate and the spring post projection on the bracket. The detent lever spring should be hooked on to the spring post projection of the bracket, and the detent lever. Oil both ends of the message drum shaft (bearing surfaces) and the hooks of all springs. Apply a thin film of grease on the detent roller.

#### 4. ADJUSTMENTS AND LUBRICATION

a. For standard adjustments and standard lubrication procedure refer to Teletype Model 28 Bulletins 234B and 250B. (Bell System refer to standardized information.)

b. Make the subject kit adjustments and lubrication as given in the text and referring to the appropriate attached figures.

c. With kit 178346 make the following "HERE IS" keylever adjustments before the keyboard hood is reinstalled on the keyboard. (See Figure 2.)

(1) Keylever Switch Position - Preliminary

Requirement: With the contact assembly guide and code lever assembly lined up per Figure 2, there should be some to 0.020 inch clearance (gauge by eye) between the right edge of the contact swinger insulator and the extension of the code lever assembly in the unoperated position.

To Adjust: Loosen the 1178 screw holding the contact assembly to the 309510 retainer bars and adjust. Tighten the screw.

#### NOTE

When the horizontal adjustment is completed, check for 0.050 inch to 0.075 inch clearance between the contact assembly spring and the keyboard wedge retainer. Bend the 309510 retainer bars if necessary.

(2) Keylever Switch Vertical Adjustment

**Requirement:** With the unit in the stop position and the keylever depressed to a point where the clutch engages or the intended function selected, the center and lower contact shall just close or have a maximum gap of 0.008 inch.

**To Adjust:** Loosen the two 156740 screws which fasten the 309508 and 309509 brackets on the two 121473 studs and position the complete mounting assembly.

d. With kit 178346 make the 162878 pulsing contact adjustment referring to Figures 5, 6, and 7. (Note on page 10.)

(1) With the pulsing contact installed on the signal generator, there should be at least .010 inch clearance between the contact guard and the rocker bail assembly. (Refer to Figure 6.) To adjust - loosen the two contact assembly mounting screws and position the contact assembly.

(2) Rotate the main shaft until the lower extension of the cam follower arm rests on the high part of the cam. The clutch should now be in a latched position. There should be .015 inch to .025 inch clearance between the contacts points. (Refer to Figure 5.) To adjust - loosen the two mounting bracket screws, leaving the bottom screws friction tight and position the mounting bracket to meet this requirement. Tighten the mounting screws.

(3) There shall be at least .015 inch clearance between the lower extension of the cam follower arm and the inside surface of the clutch disk. To adjust - loosen the two mounting screws and position the cam follower hinge. (Refer to Figure 6.)

NOTE

When checking this adjustment, rotate the main shaft several times and check the entire cycle. Make sure the lower extension of the follower arm does not come in contact with the adjusting disk mounting screws.

e. The 178316 modification kit

NOTE

The 178316 modification kit is adjusted at the factory and the adjustments given should be made only if there is reason to believe they may have been disturbed.

(1) For standard adjustments and lubrication procedure see Teletype Model 28 Bulletin 234B. Change the values of the clutch magnet armature bail spring adjustment (Figure 3-6) from 3 to 4-1/2 ozs. to 2-1/2 to 4 ozs.

(2) The adjustments on Figures 11 through 13 must be made with the 176765 code message drum parts installed on the 176715 distributor assembly.

\*

\*

\*



500655

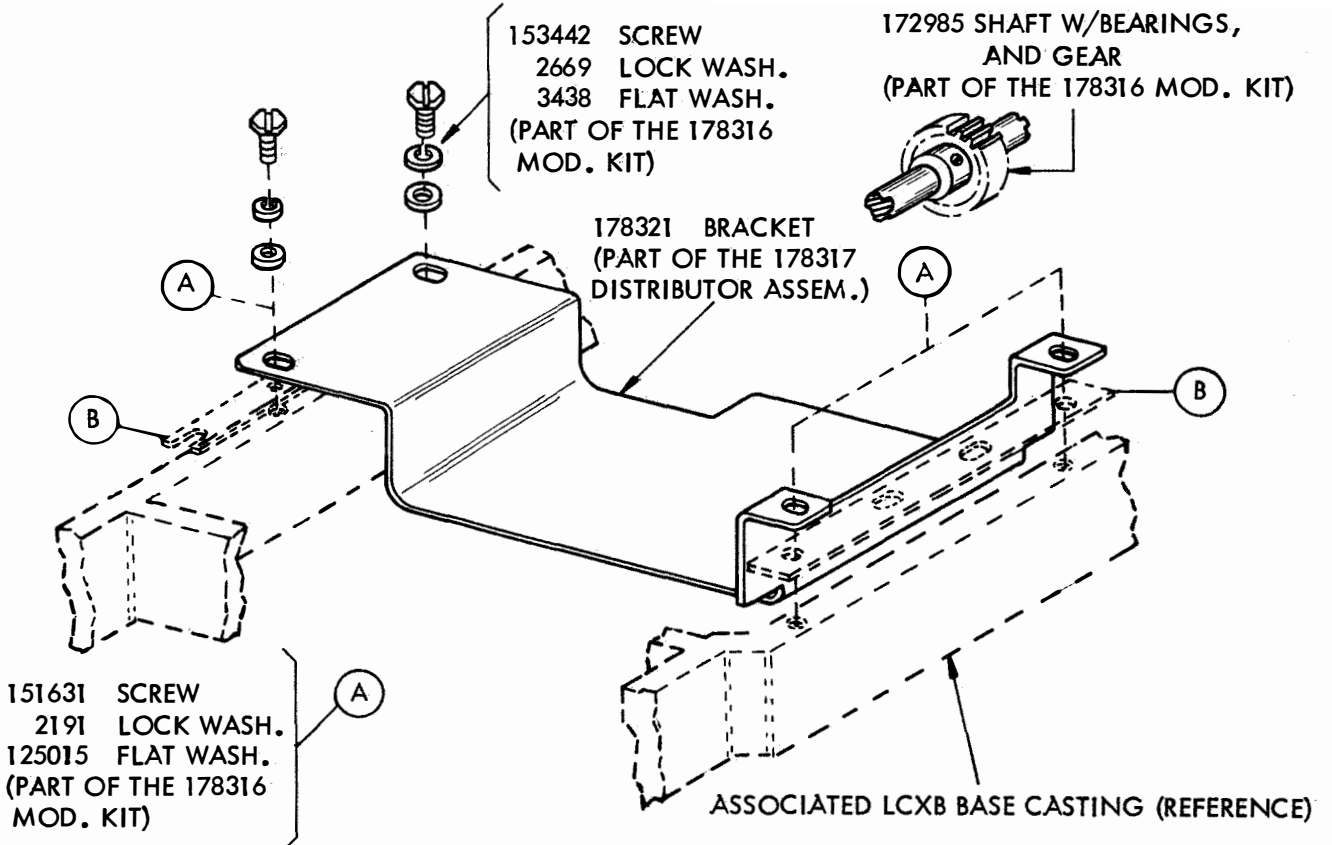

MOUNTING THE 178316 KIT

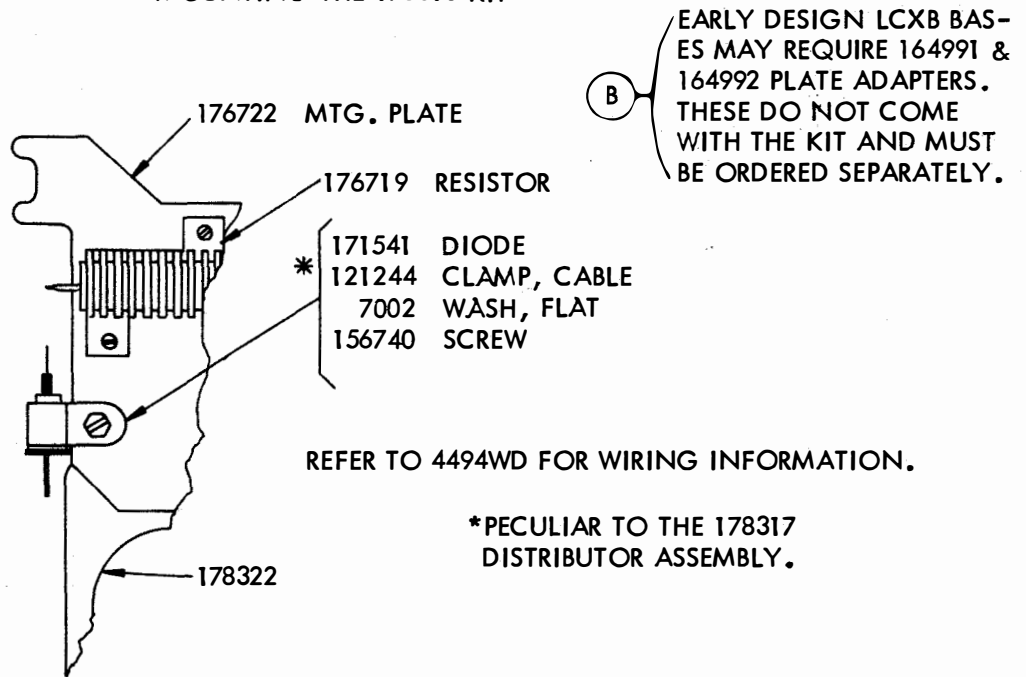

REFER TO 4494WD FOR WIRING INFORMATION.

\*PECULIAR TO THE 178317 DISTRIBUTOR ASSEMBLY.

FIGURE 1

50065S

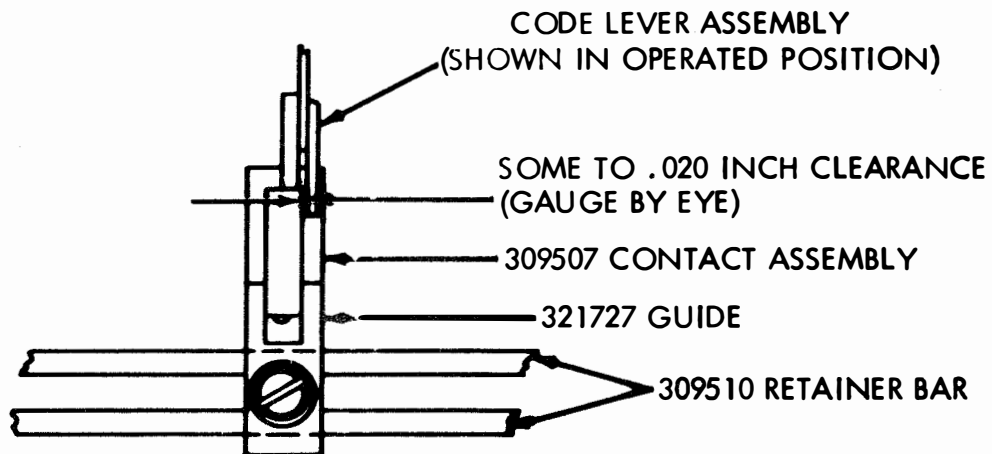
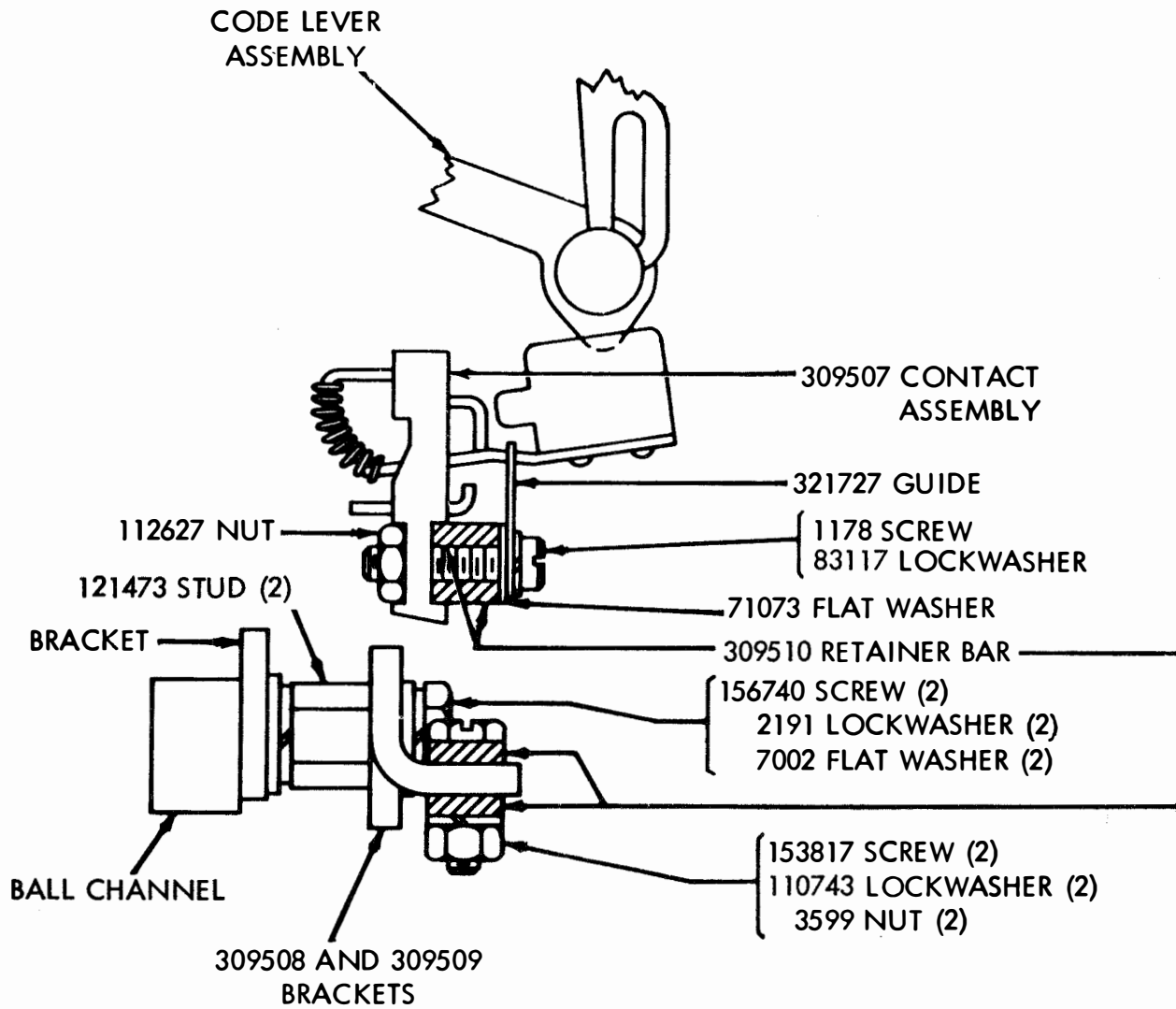
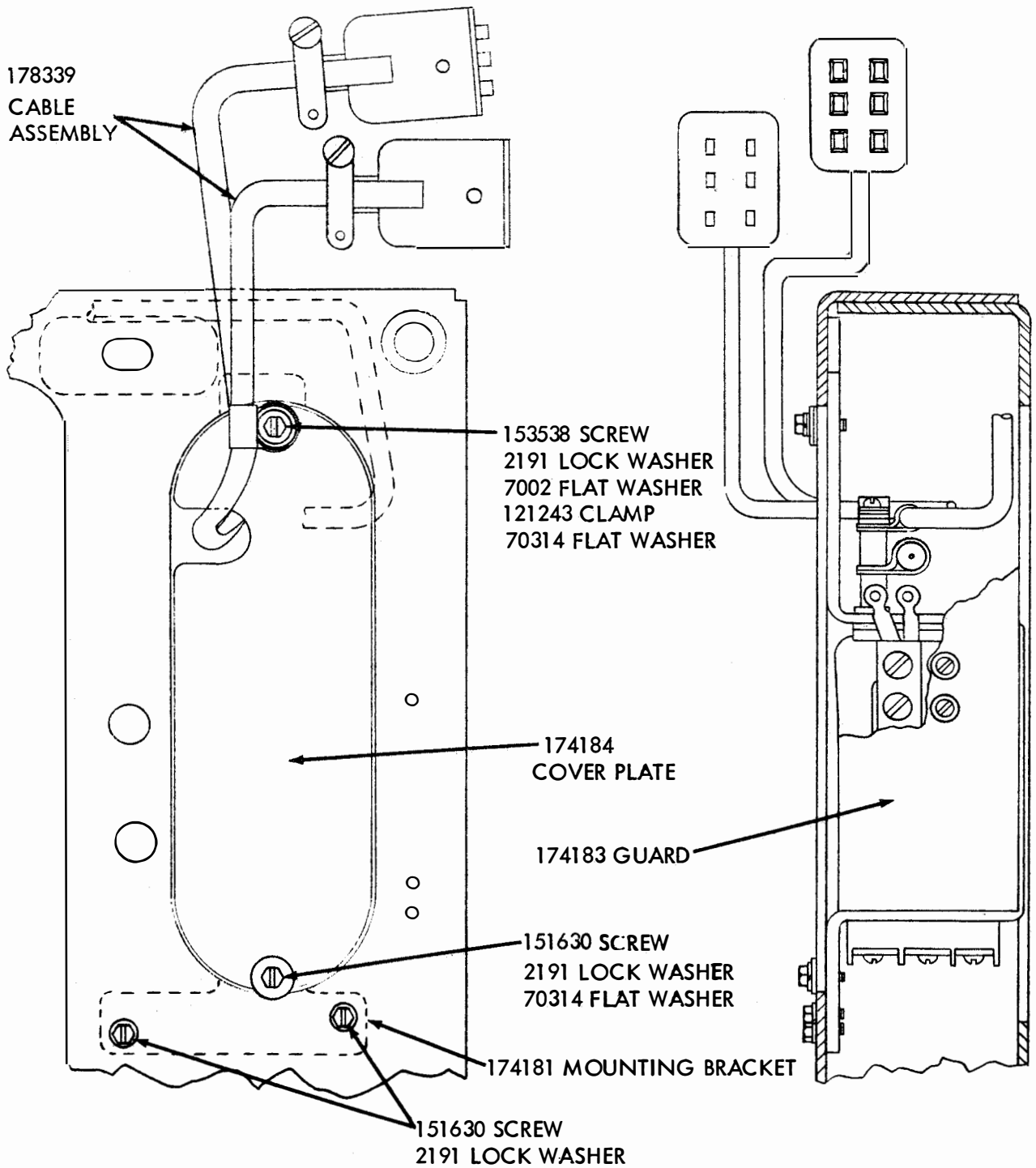

Figure 2





KEYBOARD BASE  
(VIEW OF RIGHT REAR SHOWING PARTIAL  
VIEW OF 178399 ASSEMBLY)

FIGURE 3.

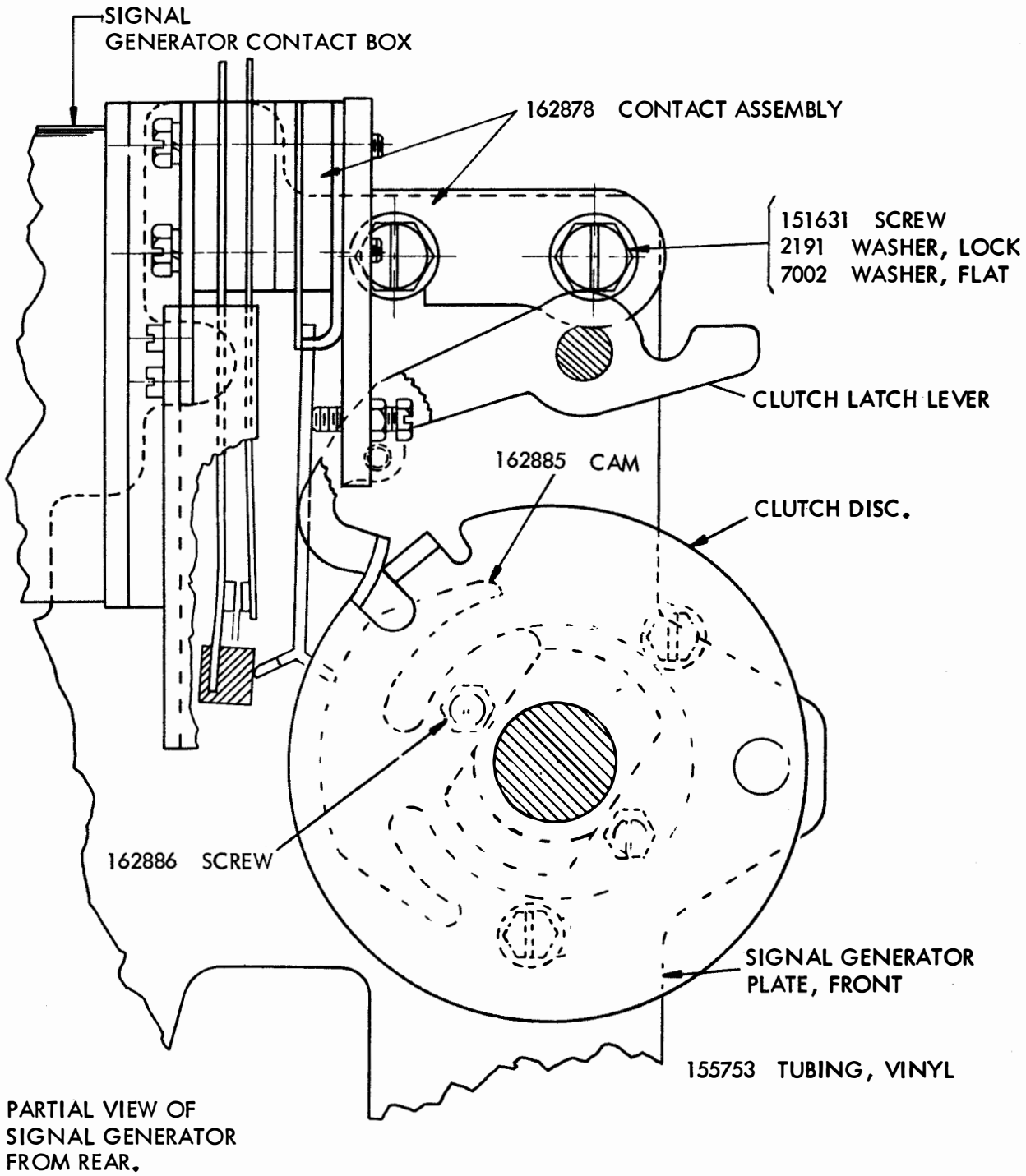

FIGURE 4.

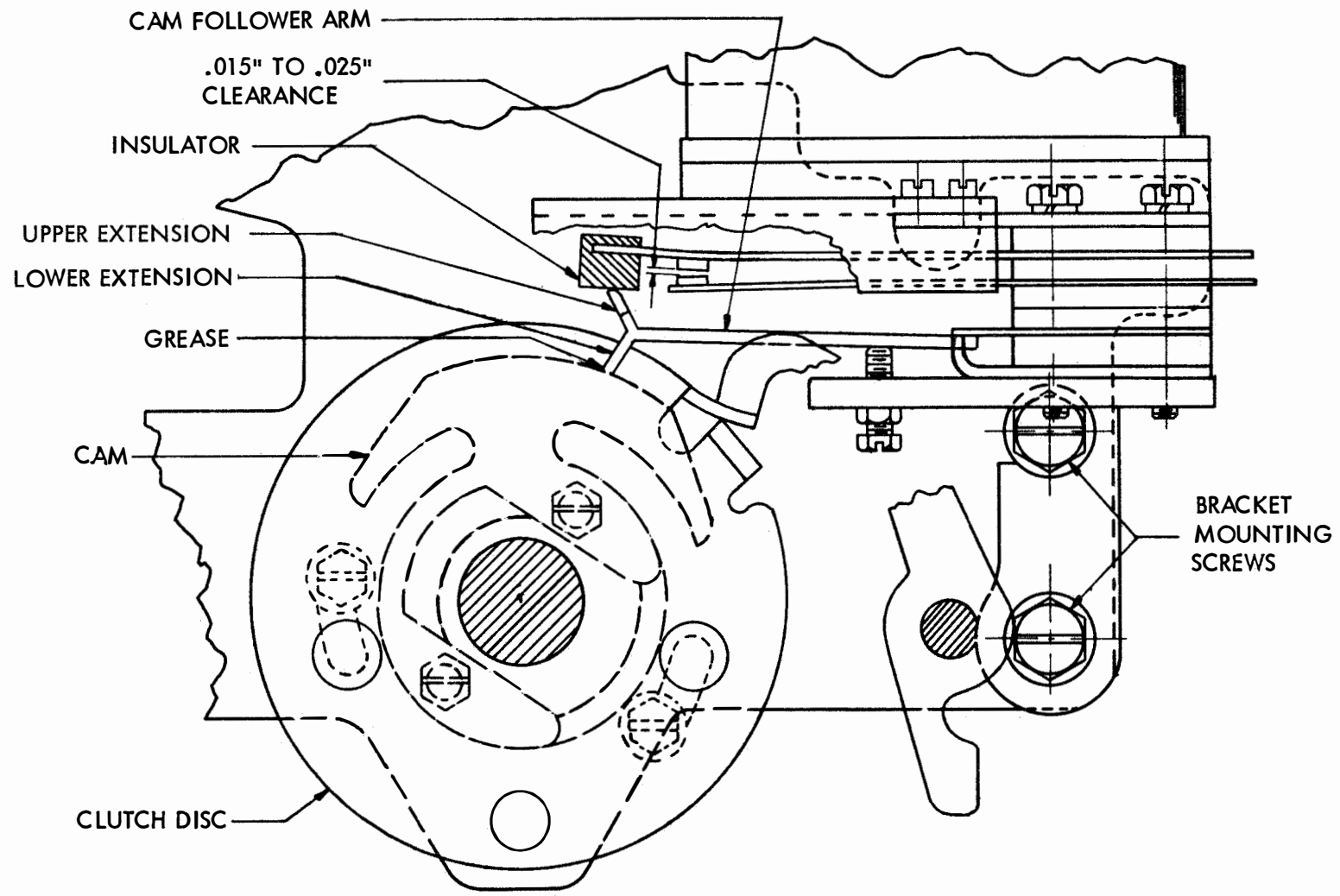

FIGURE 5.

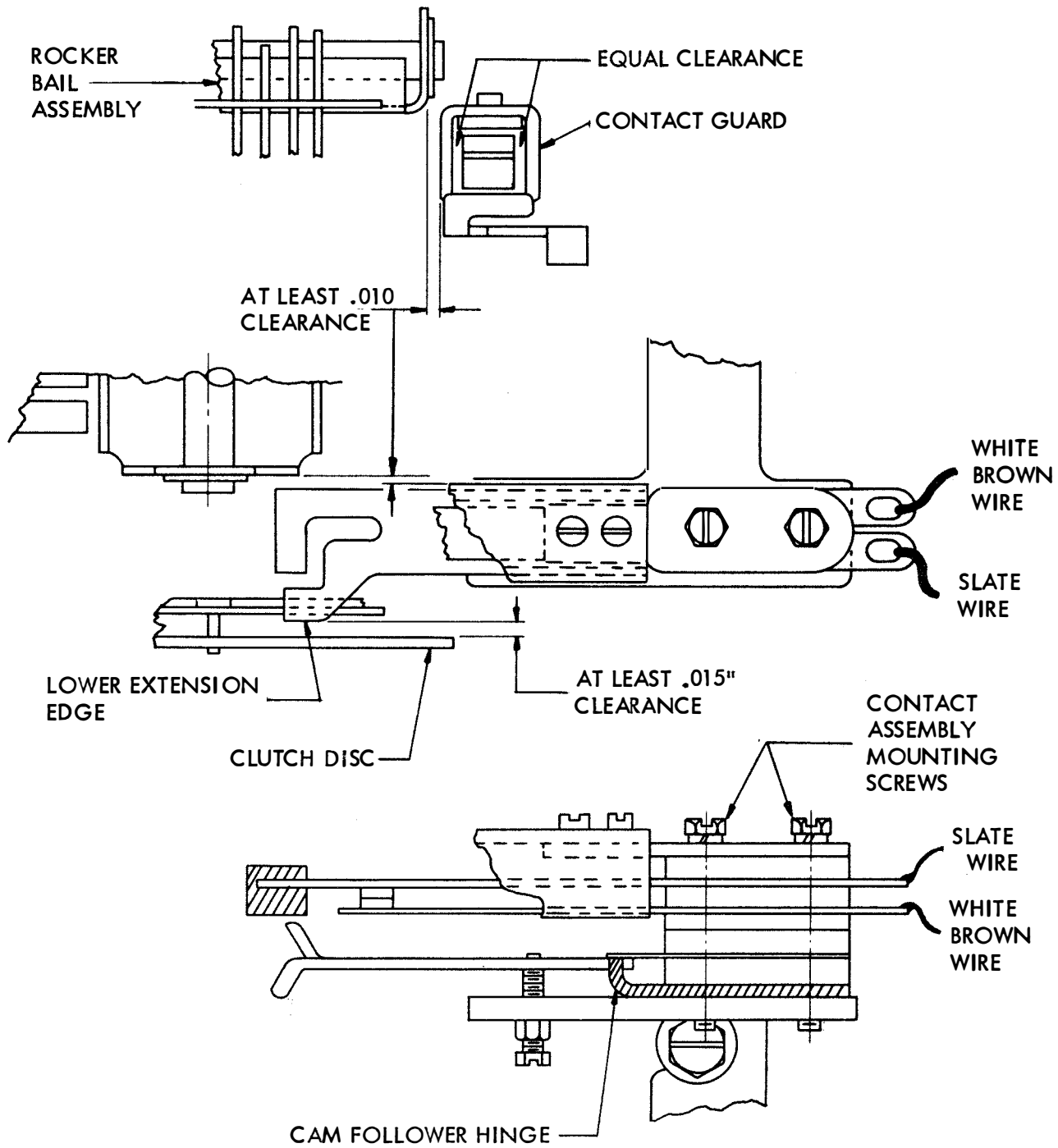

FIGURE 6.

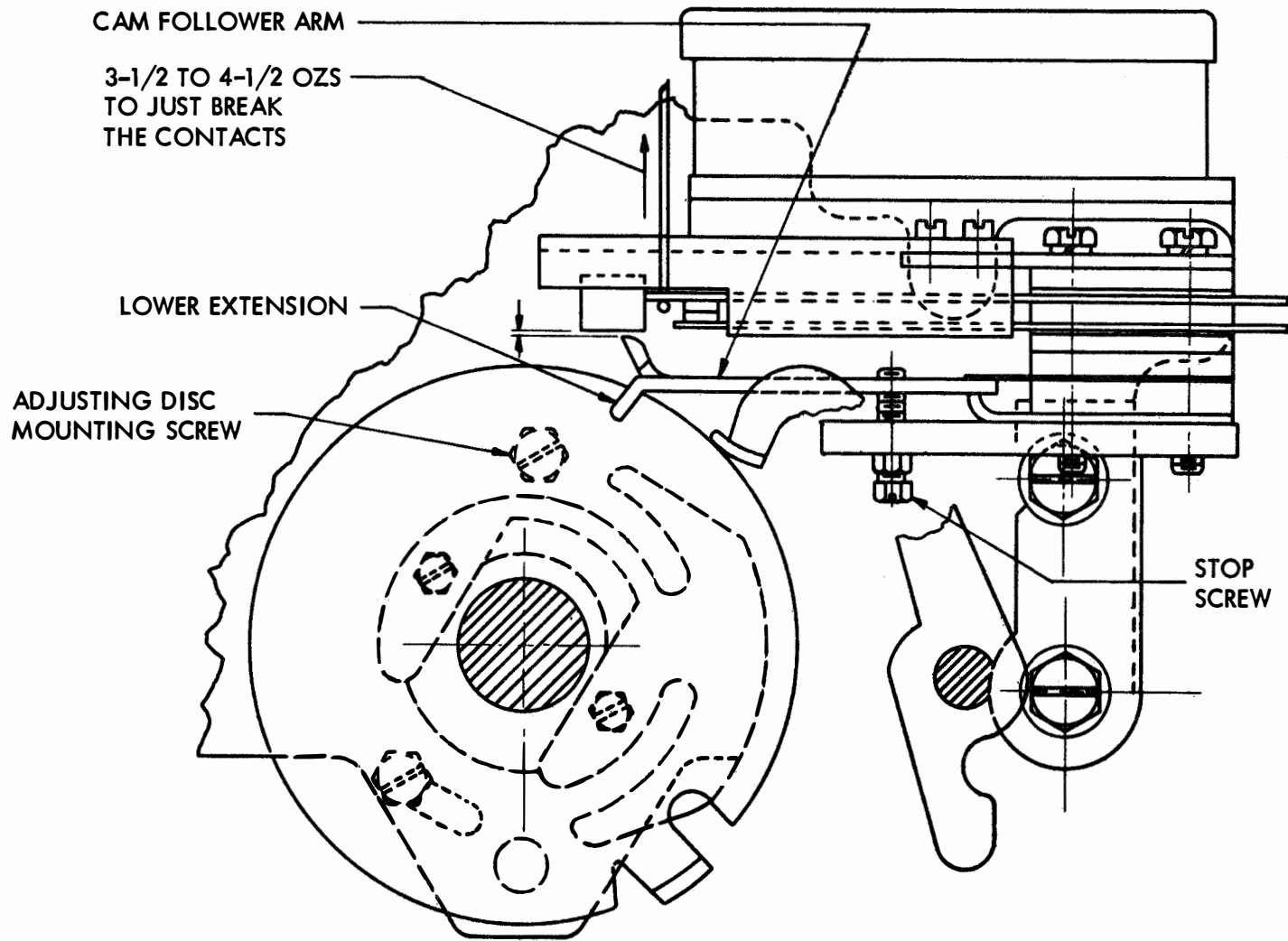
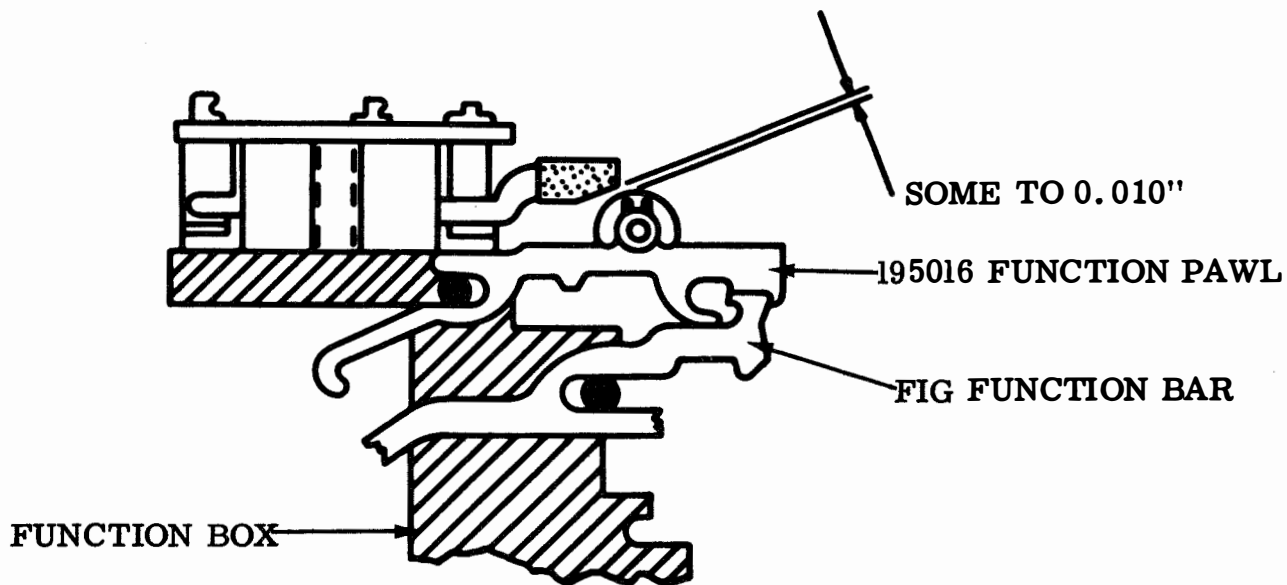
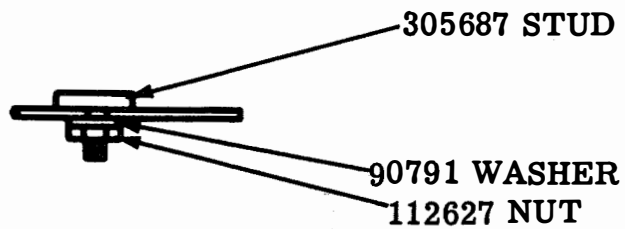

FIGURE 7.

50065S



FIGURES CONTACT ADJUSTMENT

**REQUIREMENT**

WITH STUNT BOX ON TYPING UNIT AND "LETTERS" COMBINATION MANUALLY SET UP ON TYPING UNIT SELECTOR MECHANISM, ROTATE TYPING MAIN SHAFT UNTIL FUNCTION PAWL IS IN EXTREME FORWARD (TOWARDS CONTACT INSULATOR) POSITION AS SHOWN.

SOME TO 0.010" CLEARANCE BETWEEN CONTACT INSULATOR AND THE ADJUSTING STUD.

**TO ADJUST**

LOOSEN THE ADJUSTING STUD MOUNTING NUT AND MOVE ADJUSTING STUD TO MEET REQUIREMENT. RETIGHTEN MOUNTING NUT.

Figure 8

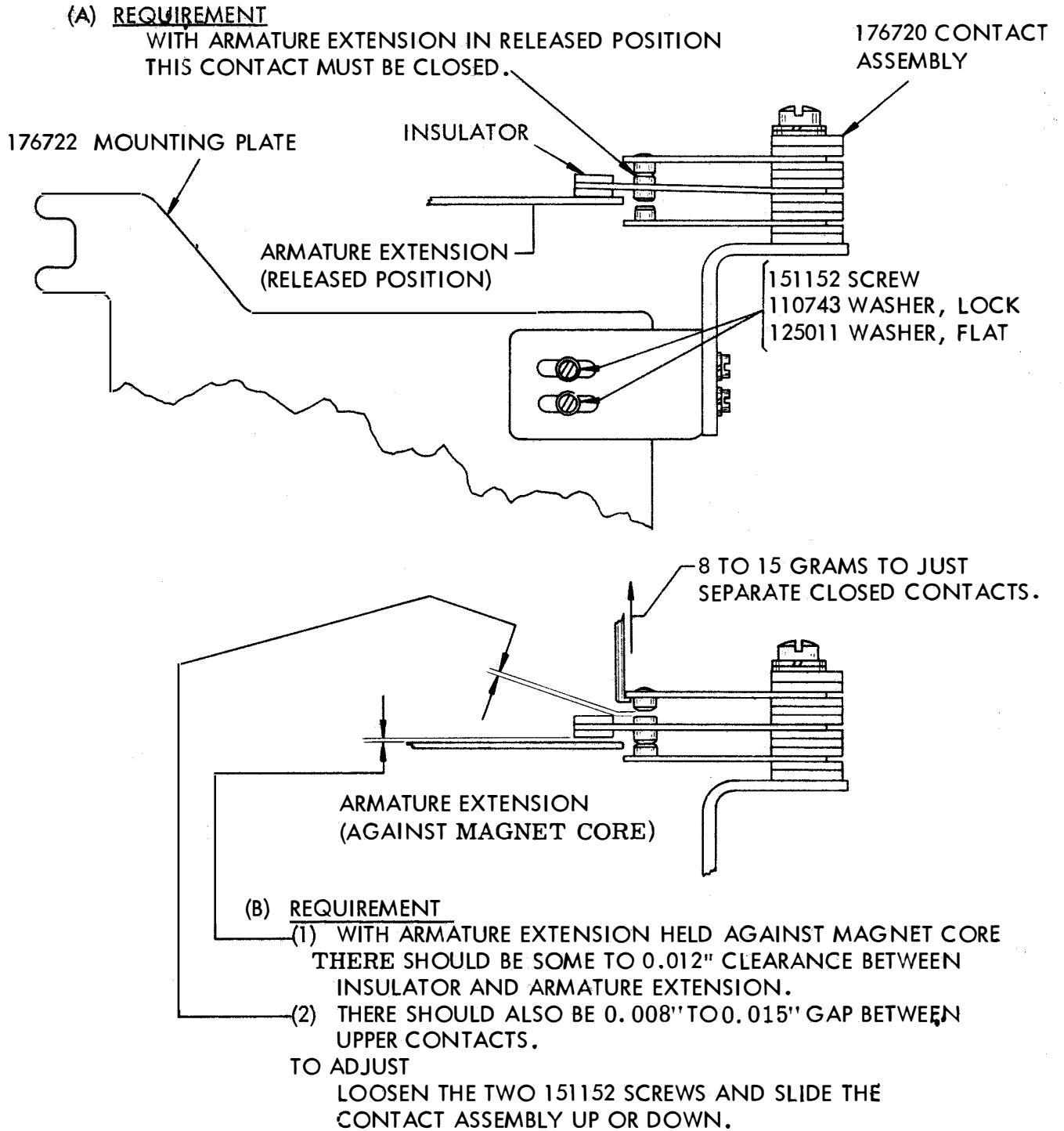
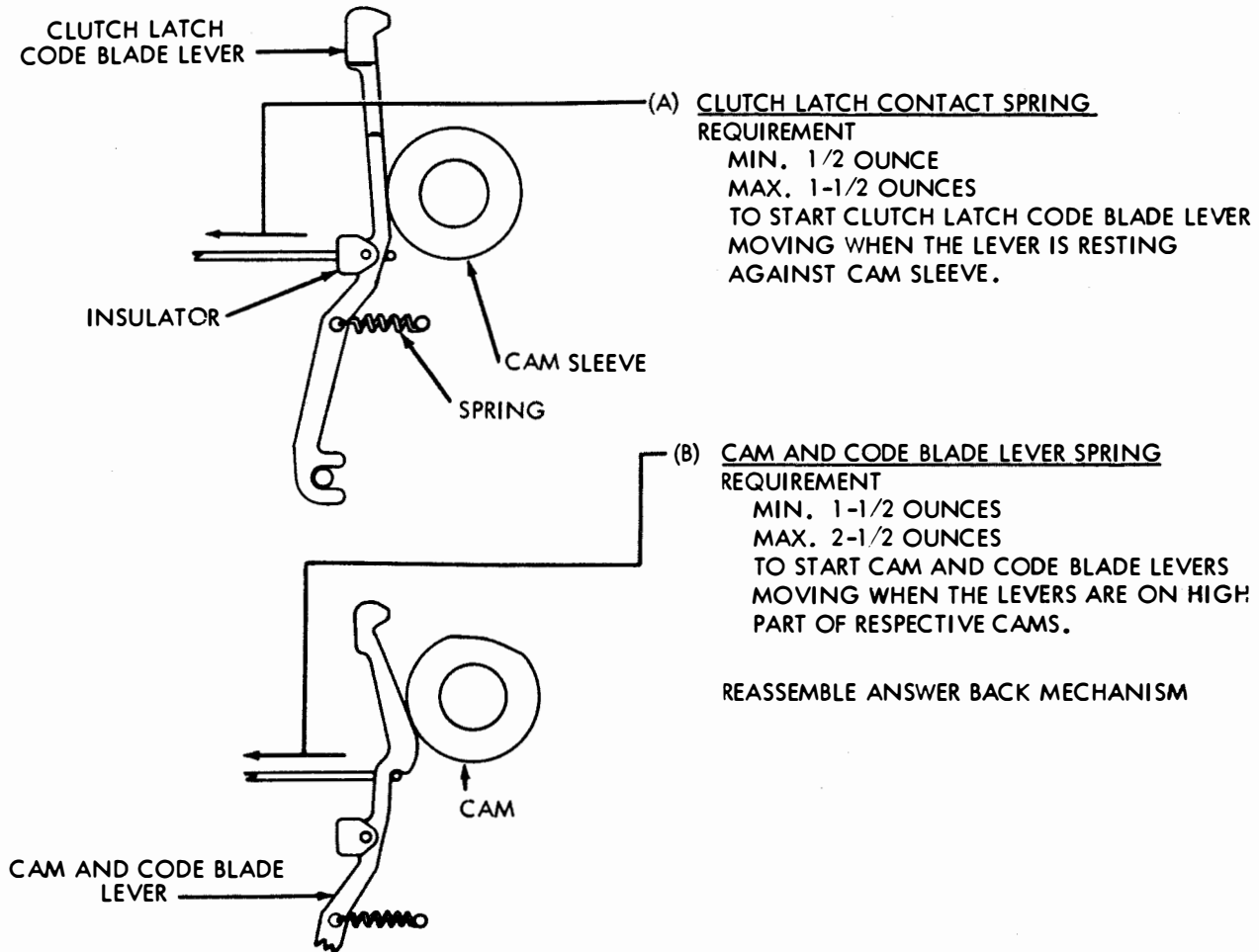

FIGURE 9

NOTE: TO CHECK TENSIONS (A) AND (B), REMOVE ENTIRE ANSWER BACK MECHANISM FROM ITS BRACKET, REMOVE MESSAGE DRUM AND TAKE OFF THE CONTACT BLOCK.



ANSWER BACK MECHANISM  
 FIGURE 10.



**(D) CLUTCH LATCHING CONTACT GAP REQUIREMENT**

GAP BETWEEN CLUTCH LATCHING CONTACTS SHOULD BE  
MIN. 0.025 INCH  
MAX. 0.035 INCH

**TO CHECK**

ROTATE MESSAGE DRUM UNTIL CLUTCH LATCH CODE BLADE LEVER IS RESTING ON STOP PROJECTION OF STOP BLADE.

**TO ADJUST**

POSITION CONTACT SCREW

**(C) CAM FOLLOWER CODE BLADE CLEARANCE REQUIREMENT**

CLEARANCE BETWEEN CAM FOLLOWER CODE BLADE AND ASSOCIATED TINE ON CODE BLADE OF MESSAGE DRUM SHOULD BE  
MIN. 0.007 INCH --- MAX. 0.020 INCH

**TO CHECK**

DISENGAGE CLUTCH. TINES OF CODE BLADES SHOULD BE OPPOSITE PROJECTIONS OF CAM FOLLOWER CODE BLADES.

**TO ADJUST**

POSITION BRACKET WITH MOUNTING SCREWS LOOSENED.

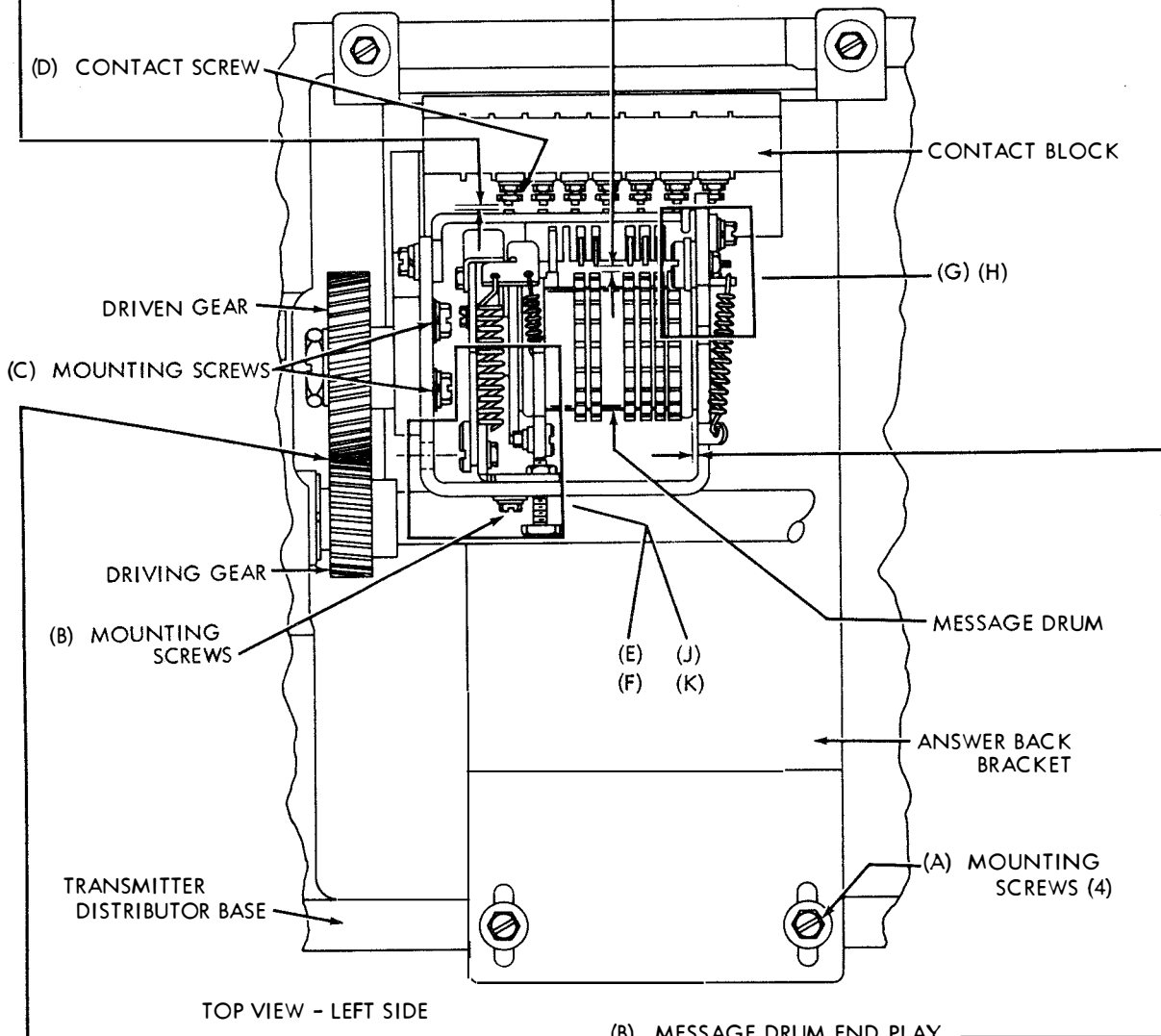

TOP VIEW - LEFT SIDE

**(A) ANSWER BACK POSITION REQUIREMENT**

BACKLASH BETWEEN DRIVEN GEAR AND ITS DRIVER SHOULD BE  
MIN. 0.005 INCH  
MAX. 0.010 INCH

**TO ADJUST**

POSITION ANSWER BACK BRACKET WITH 4 MOUNTING SCREWS LOOSENED.

**(B) MESSAGE DRUM END PLAY REQUIREMENT**

END PLAY BETWEEN MESSAGE DRUM AND BRACKET OR DRIVE PLATE SHOULD BE  
MIN. SOME  
MAX. 0.012 INCH

**TO ADJUST**

POSITION REAR MESSAGE DRUM BRACKET WITH THE TWO MOUNTING SCREWS LOOSENED. KEEP BRACKET SQUARE WITH DRUM DRIVE PLATE.

ANSWER BACK MECHANISM

FIGURE 11.

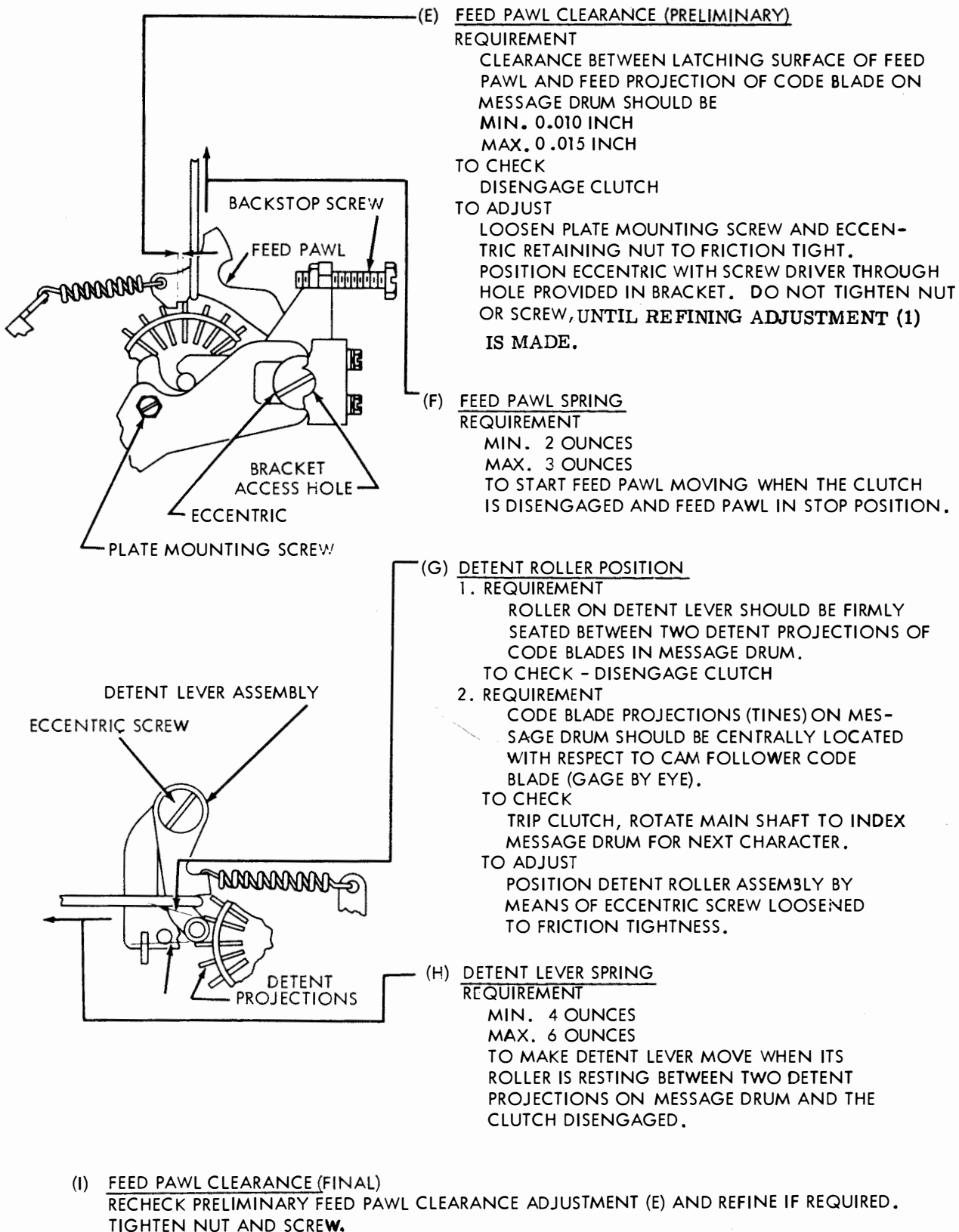

ANSWER BACK MECHANISM

FIGURE 12.

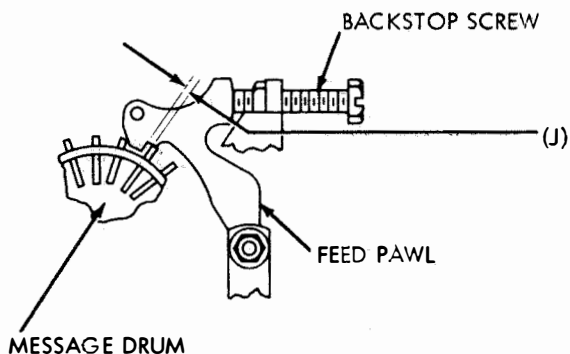

(J) FEED PAWL BACKSTOP REQUIREMENT

CLEARANCE BETWEEN LATCHING SURFACE OF FEED PAWL AND ADJACENT FEED PROJECTION ON MESSAGE DRUM SHOULD BE  
 MIN. 0.010 INCH  
 MAX. 0.015 INCH

TO CHECK

TRIP CLUTCH, ROTATE MAIN SHAFT SLOWLY UNTIL FEED PAWL REACHES MAXIMUM REARWARD TRAVEL.

TO ADJUST

LOOSEN LOCK NUT AND POSITION BACKSTOP SCREW.

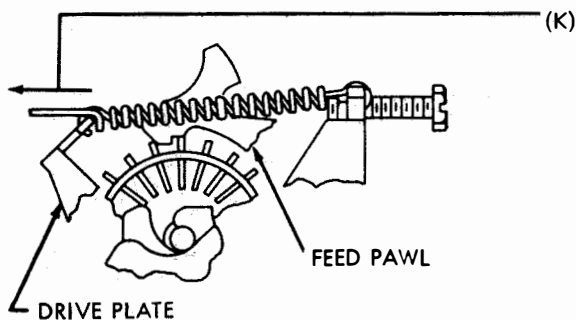

(K) DRIVE PLATE SPRING REQUIREMENT

MIN. 18 OUNCES  
 MAX. 24 OUNCES

TO MOVE FEED PAWL FROM STOP POSITION (CLUTCH DISENGAGED).

**CODING THE ANSWER-BACK FEATURE OF THE TELETYPE TRANSMITTER DISTRIBUTOR BASE LCXB**

1. THE MESSAGE DRUM HAS A CAPACITY OF 21 CHARACTERS. THE FIRST CHARACTER TRANSMITTED MUST BE A "LETTERS" COMBINATION; THE REMAINING 20 MAY BE ANY CHARACTER DESIRED. CHARACTERS ARE DETERMINED BY DETACHABLE CODE BLADES SET IN THE MESSAGE DRUM. SINCE PROJECTIONS ON THE CODE BLADES ARE USED TO ROTATE THE DRUM, ALL OF ITS 21 SLOTS MUST BE OCCUPIED BY A BLADE.

2. THE LAST CHARACTER TRANSMITTED IS DETERMINED BY A SPECIAL STOP CODE BLADE. THREE STOP BLADES ARE INCLUDED, SO THAT, EQUALLY SPACED ABOUT THE CODE DRUM IT WOULD RESULT IN 3 UNIFORM MESSAGES OF SIX CHARACTERS EACH, PRECEDED BY A "LETTERS" COMBINATION.

3. CODE A BLADE BY BREAKING OFF THE UNWANTED TINES AT THE SCORED LINE AT THE BASE OF THE TINE. FIGURE 14 INDICATES WHICH TINES ARE TO BE REMOVED FOR A PARTICULAR CHARACTER. TO PREVENT DISTORTION OF A CODE BLADE, EACH BLADE SHOULD BE HELD SECURELY NEAR THE SCORE MARK OF THE TINE TO BE REMOVED.

**ANSWER BACK MECHANISM**

**FIGURE 13.**

CODING ANSWER BACK CONT'D.

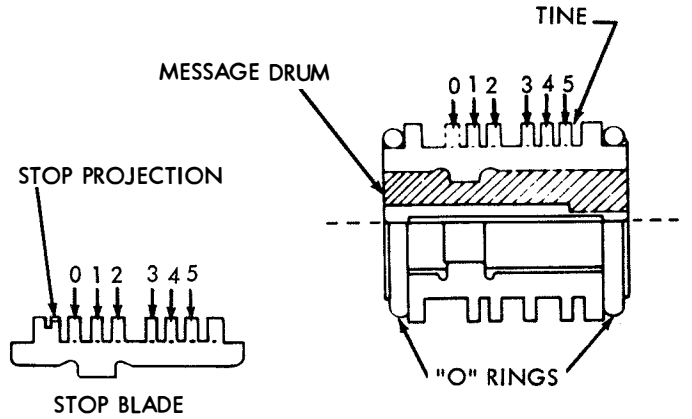
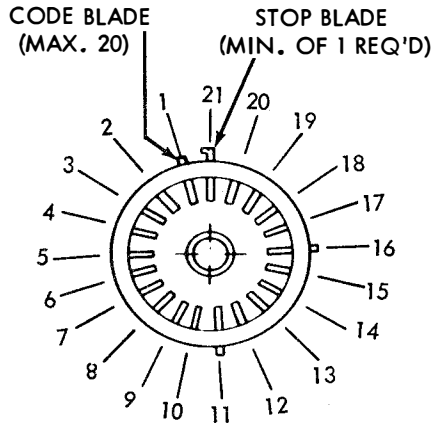

4. PLACE AN "O" RING IN THE GROOVE ON THE RIM OF THE MESSAGE DRUM WHICH IS FURTHEST FROM THE SLOT IN THE CENTER PORTION OF THE DRUM. INSTALL A STOP BLADE IN ANY SLOT POSITION IN THE DRUM BY FIRST INSERTING THE BLADE UNDER THE "O" RING AND THEN ROTATING THE BLADE TOWARD THE CENTER OF THE DRUM UNTIL IT IS FULLY SEATED.

5. CODE THE DRUM IN A COUNTER-CLOCKWISE DIRECTION BEGINNING WITH THE NO. 1 BLADE ADJACENT TO THE STOP BLADE. INSTALL EACH CODED BLADE IN THE PROPER SLOT POSITION INSERTING THE BLADE UNDER THE "O" RING AS IN PARAGRAPH 4.

- — LEAVE TINE
- — REMOVE TINE

6. AFTER FILLING THE DRUM, ENCIRCLE THE BLADES BY PLACING ANOTHER "O" RING IN THE GROOVE ON THE OPPOSITE RIM OF THE DRUM.

LETTERS	TYPICAL FIG. ARRGT	CODE				
		1	2	3	4	5
A	—	■	■	■	■	■
B	?	■	■	■	■	■
C	:	■	■	■	■	■
D	\$	■	■	■	■	■
E	3	■	■	■	■	■
F	!	■	■	■	■	■
G	&	■	■	■	■	■
H	#	■	■	■	■	■
I	8	■	■	■	■	■
J	'	■	■	■	■	■
K	(	■	■	■	■	■
L	)	■	■	■	■	■
M	.	■	■	■	■	■
N	,	■	■	■	■	■
O	9	■	■	■	■	■
P	0	■	■	■	■	■
Q	!	■	■	■	■	■
R	4	■	■	■	■	■
S	BELL	■	■	■	■	■
T	5	■	■	■	■	■
U	7	■	■	■	■	■
V	;	■	■	■	■	■
W	2	■	■	■	■	■
X	/	■	■	■	■	■
Y	6	■	■	■	■	■
Z	"	■	■	■	■	■
CARRIAGE RETURN		■	■	■	■	■
LINE FEED		■	■	■	■	■
LETTERS SHIFT		■	■	■	■	■
FIGURES SHIFT		■	■	■	■	■
SPACE		■	■	■	■	■
BLANK		■	■	■	■	■

7. PLACE A THIN COAT OF GREASE ON THE SHAFT AND STUD OF THE DRIVE PLATE. INSERT THE SHAFT PORTION OF THE DRIVE PLATE INTO THE MESSAGE DRUM (NOTE THAT DUE TO A DIFFERENCE IN HOLE DIAMETERS IN THE MESSAGE DRUM, THE SHAFT CAN BE INSERTED ONLY ONE WAY). HOOK THE SPRING BETWEEN THE DRIVE PLATE AND THE FEED PAWL. OIL BOTH ENDS OF THE SPRING.

8. TO INSERT THE MESSAGE DRUM ASSEMBLY INTO THE DISTRIBUTOR ASSEMBLY, TRIP THE CLUTCH AND ROTATE THE DISTRIBUTOR MAIN SHAFT UNTIL THE DRIVE LEVER ASSEMBLY IS ON THE HIGH PART OF THE CAM, THEN INSERT THE MESSAGE DRUM ASSEMBLY BETWEEN THE MOUNTING BRACKETS. NOTE THAT THE DRIVE PLATE HAS A STUD WELDED ON TO IT; THIS STUD MUST GO UNDER THE DRIVE LEVER ASSEMBLY. THEN ROTATE THE MAIN SHAFT TO LATCH THE CLUTCH. NEXT HOOK THE DRIVE PLATE SPRING BETWEEN THE DRIVE PLATE AND THE SPRING POST PROJECTION ON THE BRACKET. THE DETENT LEVER SPRING SHOULD BE HOOKED ON TO THE SPRING POST PROJECTION OF THE BRACKET, AND THE DETENT LEVER. LUBRICATE THE MECHANISM ACCORDING TO THE LUBRICATION FIGURES.

NOTE:

1. STOP BLADE HAS SAME PROVISIONS FOR INDIVIDUAL CODING AS STANDARD CODE BLADE.
2. WHEN CODING THE BLADES REMOVE THE "O" POSITION TINE ON ALL STOP AND CODE BLADES.

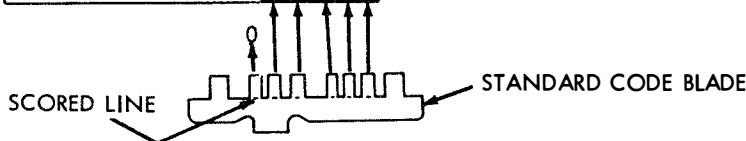

ANSWER BACK MECHANISM

FIGURE 14.

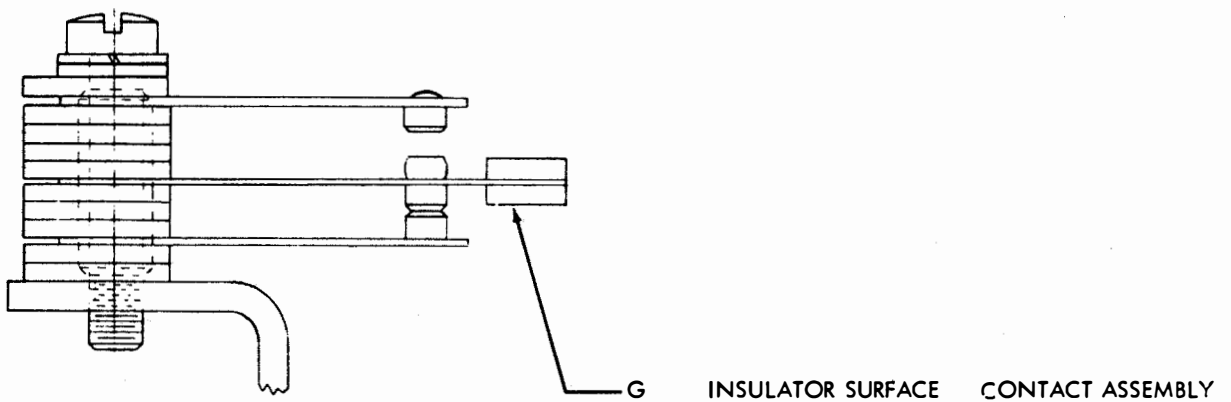
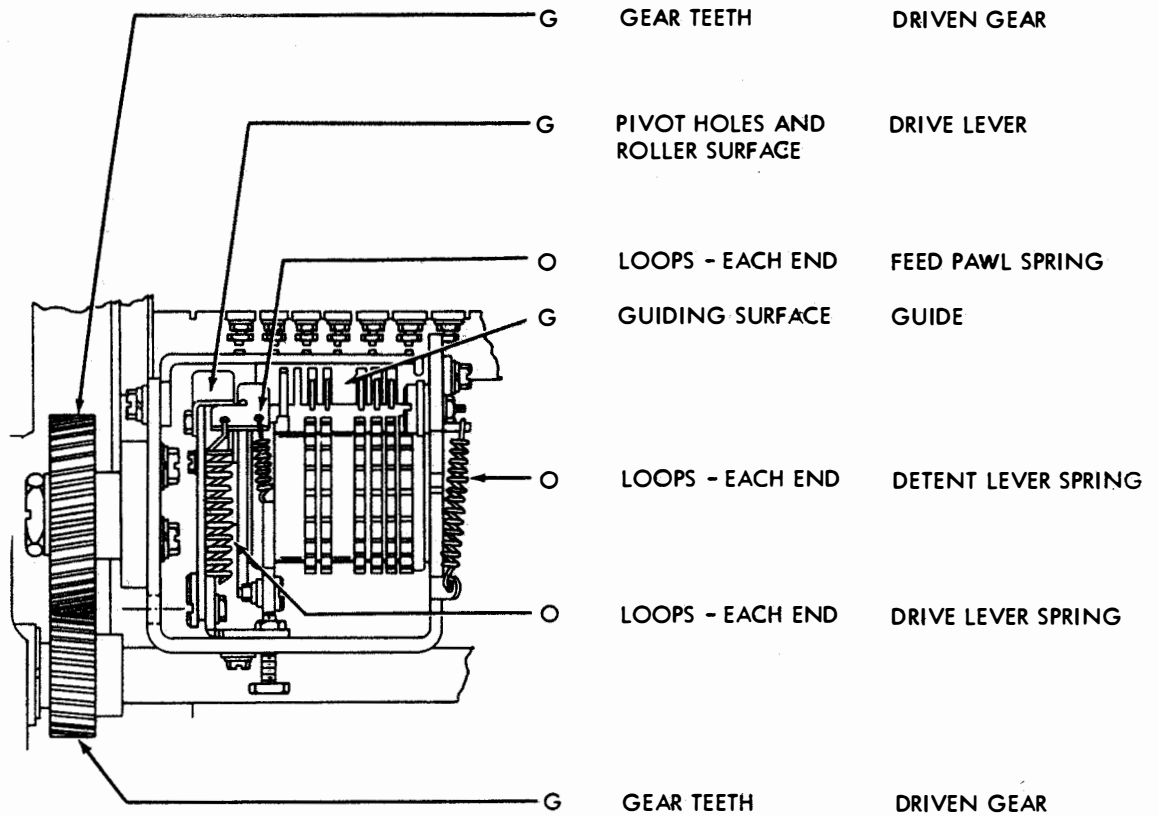

ANSWER BACK MECHANISM - LUBRICATION

FIGURE 15.

50065S

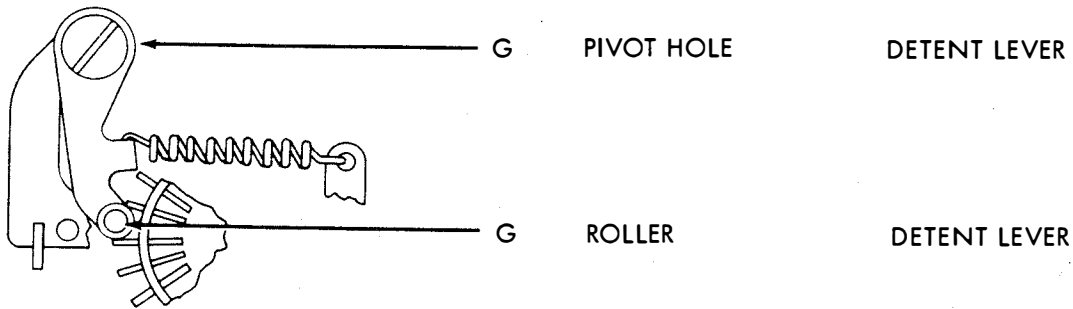
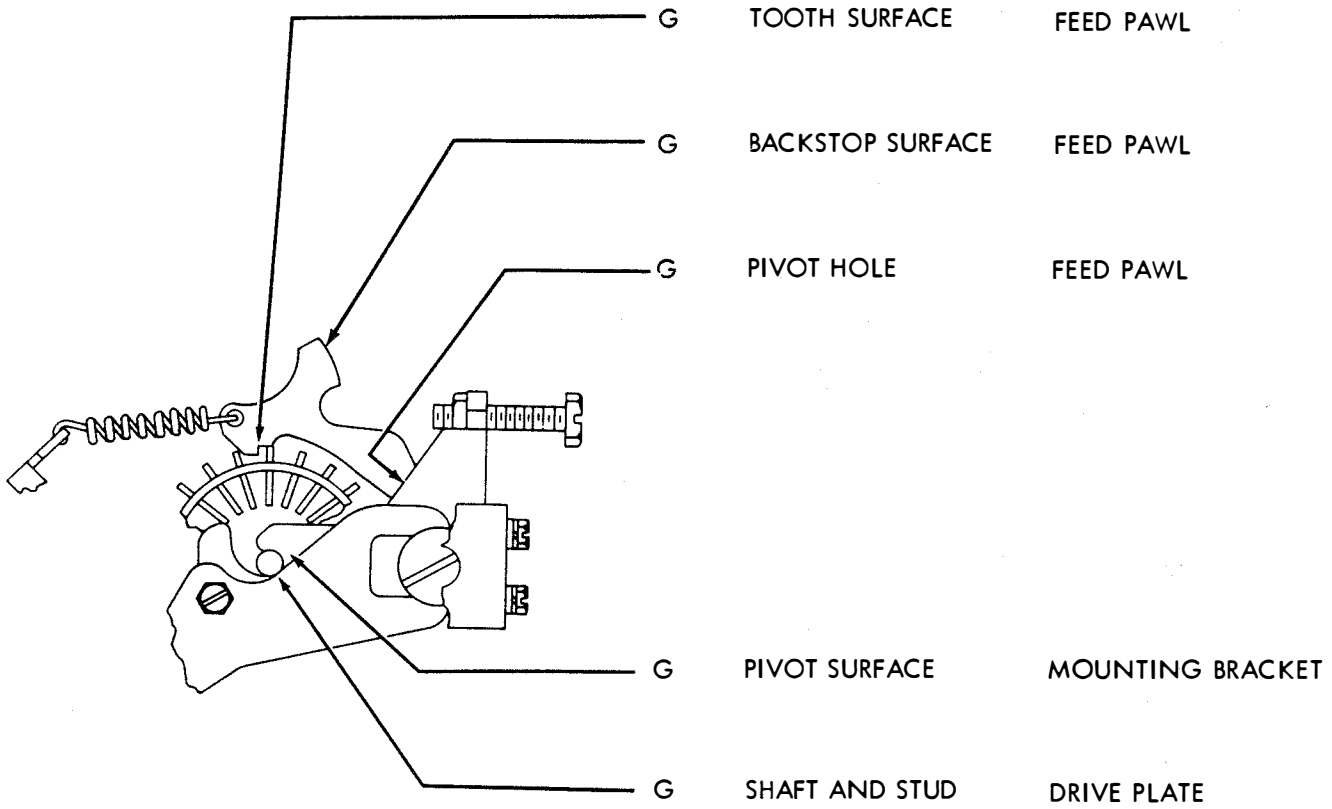

ANSWER BACK MECHANISM - LUBRICATION  
FIGURE 16.